

# Stainless Steel Tables Specification Sheet

## SMS-10-V69-T

### Short Form Specifications

Top constructed of heavy gauge type 430 stainless steel with 1½" roll on front and rear, and sides turned down 90°.

Undershelf is adjustable and constructed of heavy gauge type 430 stainless steel with marine edge. Top reinforced with hat channels and sound deadened. Constructed with uni-lok® patented gusset system with the gussets recessed into the hat channels to reduce lateral movement. Legs are 1½" O.D. stainless steel, with galvanized gussets and 1" stainless steel adjustable bullet feet.

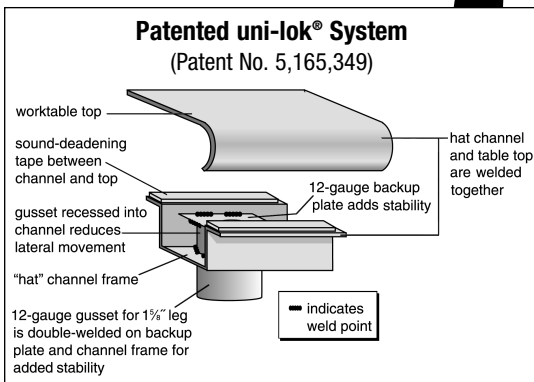

### MODELS:

<input type="checkbox"/> T2424SB	<input type="checkbox"/> T24108SB	<input type="checkbox"/> T3072SB	<input type="checkbox"/> T3660SB
<input type="checkbox"/> T2430SB	<input type="checkbox"/> T24120SB	<input type="checkbox"/> T3084SB	<input type="checkbox"/> T3672SB
<input type="checkbox"/> T2436SB	<input type="checkbox"/> T24132SB	<input type="checkbox"/> T3096SB	<input type="checkbox"/> T3684SB
<input type="checkbox"/> T2448SB	<input type="checkbox"/> T24144SB	<input type="checkbox"/> T30108SB	<input type="checkbox"/> T3696SB
<input type="checkbox"/> T2460SB	<input type="checkbox"/> T3030SB	<input type="checkbox"/> T30120SB	<input type="checkbox"/> T36108SB
<input type="checkbox"/> T2472SB	<input type="checkbox"/> T3036SB	<input type="checkbox"/> T30132SB	<input type="checkbox"/> T36120SB
<input type="checkbox"/> T2484SB	<input type="checkbox"/> T3048SB	<input type="checkbox"/> T30144SB	<input type="checkbox"/> T36132SB
<input type="checkbox"/> T2496SB	<input type="checkbox"/> T3060SB	<input type="checkbox"/> T3648SB	<input type="checkbox"/> T36144SB

### Tabletop

- Patented uni-lok® gusset system (patent #5,165,349): gussets are recessed into hat channel, reducing lateral movement.
- Top reinforced with welded-on hat channel.
- Sound-deadened between top and channels.
- 1½" (38mm)-diameter 180° rolled edges on front and rear. Ends are turned down 90° providing for flush installations when required.
- Heavy gauge type 430 polished stainless steel.

### Adjustable Undershelf

- Heavy gauge stainless steel.
- Gusset welded to each corner.
- Heavy duty marine edge design.

### Legs—1½" (41mm)-diameter

- Tables 96" (2438mm) and longer come with six legs or more.
- Heavy gauge stainless steel.
- 1" (25mm) adjustable stainless steel feet.

### Options / Accessories

- |   |   |
|---|---|
| <input type="checkbox"/> Drawer                                   | <input type="checkbox"/> Duplex receptacles                               |
| <input type="checkbox"/> Lock                                     | <input type="checkbox"/> Pot rack   |
| <input type="checkbox"/> Casters                                  | <input type="checkbox"/> Sink   |
| <input type="checkbox"/> Overshelves                              | <input type="checkbox"/> Additional undershelf                            |
| <input type="checkbox"/> Knockdown Welded Base<br>(see back page) | <input type="checkbox"/> Stabilizer Bar (for 30"-<br>and 36"-wide tables) |

### Certifications / Approvals



### Short Form Specifications

Top constructed of 16 gauge 300 series stainless steel with 1½" roll on front and rear, and sides turned down 90°. Undersheff is adjustable and constructed of heavy gauge type 430 stainless steel with marine edge. Top reinforced with hat channels and sound deadened. Constructed with uni-lok® patented gusset system with the gussets recessed into the hat channels to reduce lateral movement. Legs are 1½" O.D., stainless steel, with galvanized gussets and 1" stainless steel adjustable bullet feet.

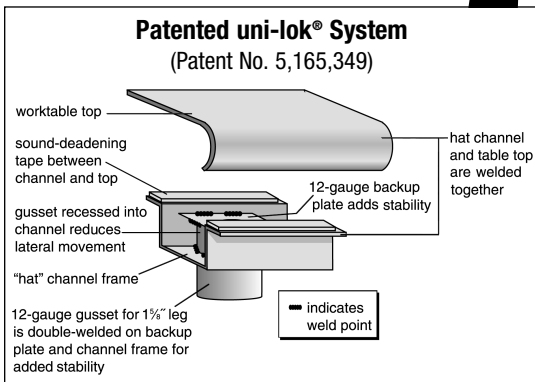

### MODELS:

- |                                   |                                    |                                    |                                    |
|-----------------------------------|------------------------------------|------------------------------------|------------------------------------|
| <input type="checkbox"/> T2424SEB | <input type="checkbox"/> T24108SEB | <input type="checkbox"/> T3072SEB  | <input type="checkbox"/> T3660SEB  |
| <input type="checkbox"/> T2430SEB | <input type="checkbox"/> T24120SEB | <input type="checkbox"/> T3084SEB  | <input type="checkbox"/> T3672SEB  |
| <input type="checkbox"/> T2436SEB | <input type="checkbox"/> T24132SEB | <input type="checkbox"/> T3096SEB  | <input type="checkbox"/> T3684SEB  |
| <input type="checkbox"/> T2448SEB | <input type="checkbox"/> T24144SEB | <input type="checkbox"/> T30108SEB | <input type="checkbox"/> T3696SEB  |
| <input type="checkbox"/> T2460SEB | <input type="checkbox"/> T3030SEB  | <input type="checkbox"/> T30120SEB | <input type="checkbox"/> T36108SEB |
| <input type="checkbox"/> T2472SEB | <input type="checkbox"/> T3036SEB  | <input type="checkbox"/> T30132SEB | <input type="checkbox"/> T36120SEB |
| <input type="checkbox"/> T2484SEB | <input type="checkbox"/> T3048SEB  | <input type="checkbox"/> T30144SEB | <input type="checkbox"/> T36132SEB |
| <input type="checkbox"/> T2496SEB | <input type="checkbox"/> T3060SEB  | <input type="checkbox"/> T3648SEB  | <input type="checkbox"/> T36144SEB |

### Tabletop

- Patented uni-lok® gusset system (patent #5,165,349): gussets are recessed into hat channel, reducing lateral movement.
- Top reinforced with welded-on hat channel.
- Sound-deadened between top and channels.
- 1½" (38mm)-diameter 180° rolled edges on front and rear. Ends are turned down 90° providing for flush installations when required.
- 16 gauge 300 series polished stainless steel.

### Adjustable Undersheff

- Heavy gauge stainless steel.
- Gusset welded to each corner.
- Heavy duty marine edge design.

### Legs—1½" (41mm)-diameter

- Tables 96" (2438mm) and longer come with six legs or more.
- Heavy gauge stainless steel.
- 1" (25mm) adjustable stainless steel feet.

### Options / Accessories

- |   |   |
|---|---|
| <input type="checkbox"/> Drawer                                   | <input type="checkbox"/> Duplex receptacles                               |
| <input type="checkbox"/> Lock                                     | <input type="checkbox"/> Pot rack   |
| <input type="checkbox"/> Casters                                  | <input type="checkbox"/> Sink   |
| <input type="checkbox"/> Overshelves                              | <input type="checkbox"/> Additional undersheff                            |
| <input type="checkbox"/> Knockdown Welded Base<br>(see back page) | <input type="checkbox"/> Stabilizer Bar (for 30"-<br>and 36"-wide tables) |



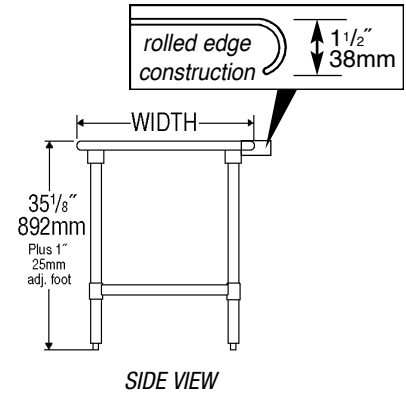
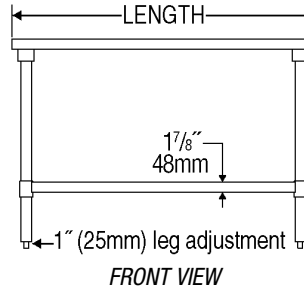
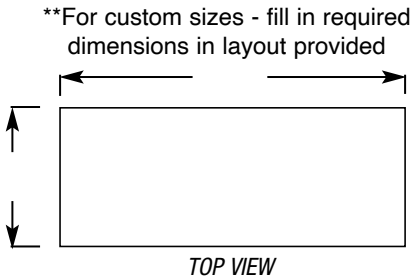

model #	# of legs	width		length		weight	
		in.	mm	in.	mm	lbs.	kg
T2424SEB	4	24"	610	24"	610	42	19.0
T2430SEB	4	24"	610	30"	762	45	20.4
T2436SEB	4	24"	610	36"	914	50	22.7
T2448SEB	4	24"	610	48"	1219	61	27.7
T2460SEB	4	24"	610	60"	1524	71	32.2
T2472SEB	4	24"	610	72"	1829	82	37.2
T2484SEB	4	24"	610	84"	2134	94	42.6
T2496SEB	6	24"	610	96"	2438	114	51.7
T24108SEB	6	24"	610	108"	2743	131	59.4
T24120SEB	6	24"	610	120"	3048	148	67.1
T24132SEB	8	24"	610	132"	3353	165	74.8
T24144SEB	8	24"	610	144"	3658	182	82.6
T3030SEB	4	30"	762	30"	762	49	22.0
T3036SEB	4	30"	762	36"	914	52	23.6
T3048SEB	4	30"	762	48"	1219	68	30.1
T3060SEB	4	30"	762	60"	1524	79	35.8
T3072SEB	4	30"	762	72"	1829	92	41.7
T3084SEB	4	30"	762	84"	2134	105	47.6
T3096SEB	6	30"	762	96"	2438	126	57.2
T30108SEB	6	30"	762	108"	2743	146	66.2
T30120SEB	6	30"	762	120"	3048	165	74.8
T30132SEB	8	30"	762	132"	3353	185	84.0
T30144SEB	8	30"	762	144"	3658	204	92.5
T3648SEB	4	36"	914	48"	1219	75	34.0
T3660SEB	4	36"	914	60"	1524	88	40.0
T3672SEB	4	36"	914	72"	1829	104	47.2
T3684SEB	4	36"	914	84"	2134	120	54.4
T3696SEB	6	36"	914	96"	2438	139	63.1
T36108SEB	6	36"	914	108"	2743	164	74.4
T36120SEB	6	36"	914	120"	3048	188	85.3
T36132SEB	8	36"	914	132"	3353	213	96.6
T36144SEB	8	36"	914	144"	3658	237	107.5

**NEW Option for Worktables with Stainless Steel Base: Knockdown Welded Base**

**PATENT PENDING**

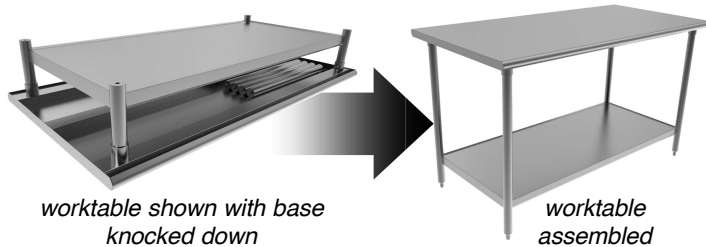

- Precision machined stainless steel threaded inserts pressed into 16 gauge 1/8"-diameter leg sections for knockdown construction
- Marine edge stainless steel undershelf welded to lower leg sections

Add suffix **"-KDWB"** to worktable model number (ex: T2436SEB-KDWB). See EG8217 for more info.



## Short Form Specifications

Top to be constructed of 14/304 stainless steel, with 1½" roll on front and rear, and sides turned down 90°. Undershelf to be adjustable and constructed of 18/304 stainless steel with marine edge. Top reinforced with stainless steel hat channels and sound deadened. Constructed with uni-lok® patented gusset system with the gussets recessed into the hat channels to reduce lateral movement. Legs to be 1½" O.D., stainless steel, with stainless steel gussets and 1" stainless steel adjustable bullet feet.

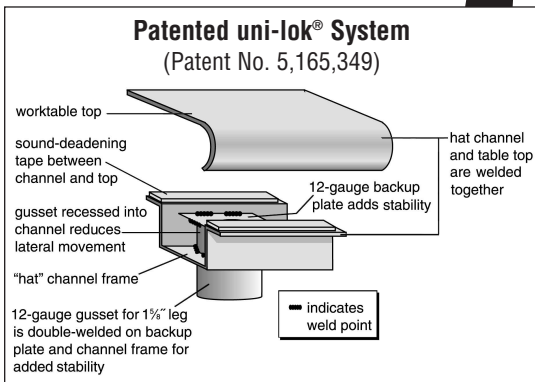

## MODELS:

<input type="checkbox"/> T2424SE	<input type="checkbox"/> T24144SE	<input type="checkbox"/> T30132SE	<input type="checkbox"/> T36144SE
<input type="checkbox"/> T2430SE	<input type="checkbox"/> T3030SE	<input type="checkbox"/> T30144SE	<input type="checkbox"/> T4848SE
<input type="checkbox"/> T2436SE	<input type="checkbox"/> T3036SE	<input type="checkbox"/> T3648SE	<input type="checkbox"/> T4860SE
<input type="checkbox"/> T2448SE	<input type="checkbox"/> T3048SE	<input type="checkbox"/> T3660SE	<input type="checkbox"/> T4872SE
<input type="checkbox"/> T2460SE	<input type="checkbox"/> T3060SE	<input type="checkbox"/> T3672SE	<input type="checkbox"/> T4884SE
<input type="checkbox"/> T2472SE	<input type="checkbox"/> T3072SE	<input type="checkbox"/> T3684SE	<input type="checkbox"/> T4896SE
<input type="checkbox"/> T2484SE	<input type="checkbox"/> T3084SE	<input type="checkbox"/> T3696SE	<input type="checkbox"/> T48108SE
<input type="checkbox"/> T2496SE	<input type="checkbox"/> T3096SE	<input type="checkbox"/> T36108SE	<input type="checkbox"/> T48120SE
<input type="checkbox"/> T24108SE	<input type="checkbox"/> T30108SE	<input type="checkbox"/> T36120SE	<input type="checkbox"/> T48132SE
<input type="checkbox"/> T24120SE	<input type="checkbox"/> T30120SE	<input type="checkbox"/> T36132SE	<input type="checkbox"/> T48144SE
<input type="checkbox"/> T24132SE			

## Tabletop

- Patented uni-lok® gusset system (patent #5,165,349): gussets are recessed into hat channel, reducing lateral movement.
- Top reinforced with welded-on hat channel.
- Sound-deadened between top and channels.
- 1½" (38mm)-diameter 180° rolled edges on front and rear. Ends are turned down 90° providing for flush installations when required.
- 14 gauge type 304 polished stainless steel.

## Adjustable Undershelf

- 18 gauge type 304 stainless steel.
- Gusset welded to each corner.
- Heavy duty marine edge design.

## Legs—1½" (41mm)-diameter

- 24" to 36" (610 to 914mm)-wide units that are 96" (2438mm) and longer come with six legs or more. 48" (1219mm)-wide units that are 72" (1829mm) and longer come with six legs or more.
- Heavy gauge stainless steel.
- 1" (25mm) adjustable stainless steel feet.

## Options / Accessories

- |  |  |
|--|--|
| <input type="checkbox"/> Drawer                      | <input type="checkbox"/> Duplex receptacles                            |
| <input type="checkbox"/> Lock                        | <input type="checkbox"/> Pot rack                                      |
| <input type="checkbox"/> Casters                     | <input type="checkbox"/> Sink  |
| <input type="checkbox"/> Stainless steel bullet feet | <input type="checkbox"/> Additional undershelf                         |
| <input type="checkbox"/> Overshelves                 | <input type="checkbox"/> Stabilizer Bar (for 30"- and 36"-wide tables) |



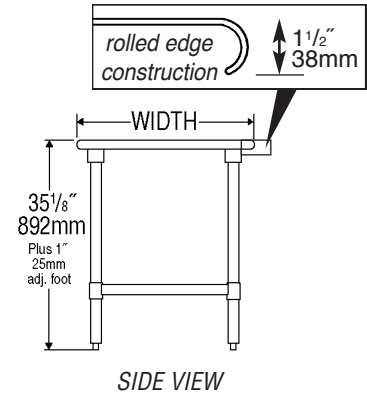
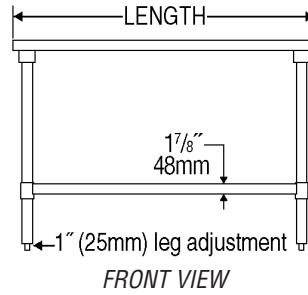
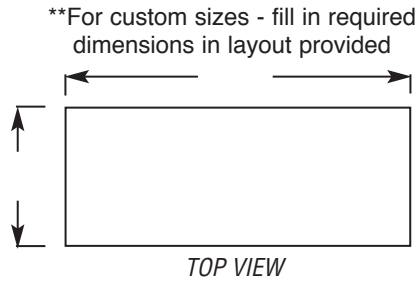

model #	# of legs	width		length		weight	
		in.	mm	in.	mm	lbs.	kg
T2424SE	4	24"	610	24"	610	46	20.9
T2430SE	4	24"	610	30"	762	50	22.7
T2436SE	4	24"	610	36"	914	55	24.9
T2448SE	4	24"	610	48"	1219	67	30.4
T2460SE	4	24"	610	60"	1524	78	35.4
T2472SE	4	24"	610	72"	1829	90	40.8
T2484SE	4	24"	610	84"	2134	103	46.3
T2496SE	6	24"	610	96"	2438	125	56.7
T24108SE	6	24"	610	108"	2743	144	65.3
T24120SE	6	24"	610	120"	3048	163	73.9
T24132SE	8	24"	610	132"	3353	186	84.4
T24144SE	8	24"	610	144"	3658	200	90.7
T3030SE	4	30"	762	30"	762	54	24.5
T3036SE	4	30"	762	36"	914	57	25.9
T3048SE	4	30"	762	48"	1219	75	34.0
T3060SE	4	30"	762	60"	1524	87	39.5
T3072SE	4	30"	762	72"	1829	101	45.8
T3084SE	4	30"	762	84"	2134	116	52.6
T3096SE	6	30"	762	96"	2438	139	63.1
T30108SE	6	30"	762	108"	2743	161	73.0
T30120SE	6	30"	762	120"	3048	182	82.6
T30132SE	8	30"	762	132"	3353	204	92.5
T30144SE	8	30"	762	144"	3658	224	101.6
T3648SE	4	36"	914	48"	1219	83	37.6
T3660SE	4	36"	914	60"	1524	97	44.0
T3672SE	4	36"	914	72"	1829	114	51.7
T3684SE	4	36"	914	84"	2134	132	59.9
T3696SE	6	36"	914	96"	2438	153	69.4
T36108SE	6	36"	914	108"	2743	180	81.6
T36120SE	6	36"	914	120"	3048	207	93.9
T36132SE	8	36"	914	132"	3353	234	106.1
T36144SE	8	36"	914	144"	3658	261	118.4
T4848SE	4	48"	1219	48"	1219	136	61.7
T4860SE	4	48"	1219	60"	1524	161	73.0
T4872SE	6	48"	1219	72"	1829	188	85.3
T4884SE	8	48"	1219	84"	2134	217	98.4
T4896SE	8	48"	1219	96"	2438	265	120.2
T48108SE	8	48"	1219	108"	2743	306	138.8
T48120SE	8	48"	1219	120"	3048	348	157.9
T48132SE	8	48"	1219	132"	3353	388	176.0
T48144SE	8	48"	1219	144"	3658	430	195.0



## Short Form Specifications

Top to be constructed of 14/304 stainless steel, with 2 $\frac{1}{16}$ " marine counter style edging on all four sides. Undershelf to be adjustable and constructed of 18/304 stainless steel, with marine edge. Top reinforced with stainless steel hat channels and sound deadened. Constructed with uni-lok<sup>®</sup> patented gusset system with the gussets recessed into the hat channels to reduce lateral movement. Legs to be 1 $\frac{1}{2}$ " O.D., stainless steel, with stainless steel gussets and 1" stainless steel adjustable bullet feet.



*worktable with flat top and stainless steel undershelf*

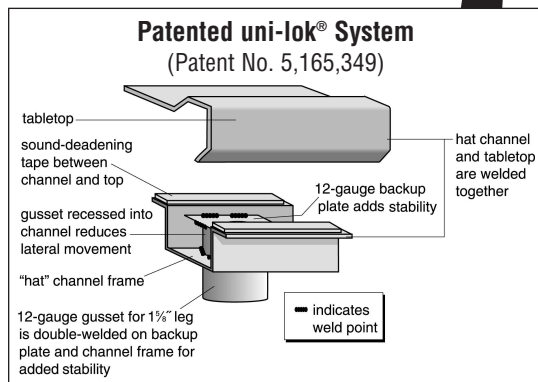

## MODELS:

- |                                    |                                    |                                    |                                    |
|------------------------------------|------------------------------------|------------------------------------|------------------------------------|
| <input type="checkbox"/> T2424SEM  | <input type="checkbox"/> T24144SEM | <input type="checkbox"/> T30132SEM | <input type="checkbox"/> T36144SEM |
| <input type="checkbox"/> T2430SEM  | <input type="checkbox"/> T3030SEM  | <input type="checkbox"/> T30144SEM | <input type="checkbox"/> T4848SEM  |
| <input type="checkbox"/> T2436SEM  | <input type="checkbox"/> T3036SEM  | <input type="checkbox"/> T3648SEM  | <input type="checkbox"/> T4860SEM  |
| <input type="checkbox"/> T2448SEM  | <input type="checkbox"/> T3048SEM  | <input type="checkbox"/> T3660SEM  | <input type="checkbox"/> T4872SEM  |
| <input type="checkbox"/> T2460SEM  | <input type="checkbox"/> T3060SEM  | <input type="checkbox"/> T3672SEM  | <input type="checkbox"/> T4884SEM  |
| <input type="checkbox"/> T2472SEM  | <input type="checkbox"/> T3072SEM  | <input type="checkbox"/> T3684SEM  | <input type="checkbox"/> T4896SEM  |
| <input type="checkbox"/> T2484SEM  | <input type="checkbox"/> T3084SEM  | <input type="checkbox"/> T3696SEM  | <input type="checkbox"/> T48108SEM |
| <input type="checkbox"/> T2496SEM  | <input type="checkbox"/> T3096SEM  | <input type="checkbox"/> T36108SEM | <input type="checkbox"/> T48120SEM |
| <input type="checkbox"/> T24108SEM | <input type="checkbox"/> T30108SEM | <input type="checkbox"/> T36120SEM | <input type="checkbox"/> T48132SEM |
| <input type="checkbox"/> T24120SEM | <input type="checkbox"/> T30120SEM | <input type="checkbox"/> T36132SEM | <input type="checkbox"/> T48144SEM |
| <input type="checkbox"/> T24132SEM |                                    |                                    |                                    |

## Tabletop

- Patented uni-lok<sup>®</sup> gusset system (patent #5,165,349): gussets are recessed into hat channel, reducing lateral movement.
- Top reinforced with welded-on hat channel.
- Sound-deadened between top and channels.
- Marine counter edge on all four sides.
- 14 gauge type 304 polished stainless steel.

## Adjustable Undershelf

- 18 gauge type 304 stainless steel.
- Gusset welded to each corner.
- Heavy duty marine edge design.

## Legs—1 $\frac{1}{2}$ " (41mm)-diameter

- 24" to 36" (610 to 914mm)-wide units that are 96" (2438mm) and longer come with six legs or more. 48" (1219mm)-wide units that are 72" (1829mm) and longer come with six legs or more.
- Heavy gauge stainless steel.
- 1" (25mm) adjustable stainless steel feet.

## Options / Accessories

- |  |  |
|--|--|
| <input type="checkbox"/> Drawer                      | <input type="checkbox"/> Duplex receptacles                            |
| <input type="checkbox"/> Lock                        | <input type="checkbox"/> Pot rack                                      |
| <input type="checkbox"/> Casters                     | <input type="checkbox"/> Sink  |
| <input type="checkbox"/> Stainless steel bullet feet | <input type="checkbox"/> Additional undershelf                         |
| <input type="checkbox"/> Overshelves                 | <input type="checkbox"/> Stabilizer Bar (for 30"- and 36"-wide tables) |



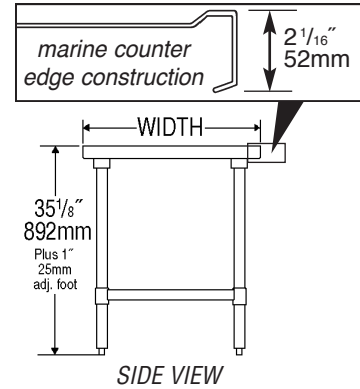
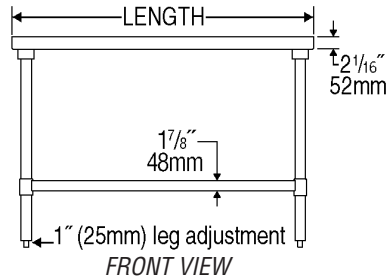
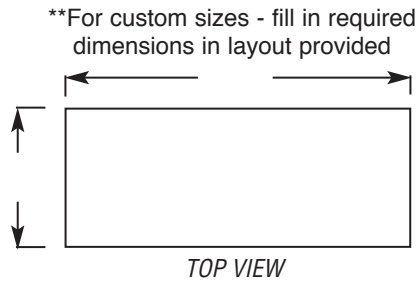

model #	# of legs	width		length		weight	
		in.	mm	in.	mm	lbs.	kg
T2424SEM	4	24"	610	24"	610	46	20.9
T2430SEM	4	24"	610	30"	762	50	22.7
T2436SEM	4	24"	610	36"	914	55	24.9
T2448SEM	4	24"	610	48"	1219	67	30.4
T2460SEM	4	24"	610	60"	1524	78	35.4
T2472SEM	4	24"	610	72"	1829	90	40.8
T2484SEM	4	24"	610	84"	2134	103	46.3
T2496SEM	6	24"	610	96"	2438	125	56.7
T24108SEM	6	24"	610	108"	2743	144	65.3
T24120SEM	6	24"	610	120"	3048	163	73.9
T24132SEM	8	24"	610	132"	3353	186	84.4
T24144SEM	8	24"	610	144"	3658	200	90.7
T3030SEM	4	30"	762	30"	762	54	24.5
T3036SEM	4	30"	762	36"	914	57	25.9
T3048SEM	4	30"	762	48"	1219	75	34.0
T3060SEM	4	30"	762	60"	1524	87	39.5
T3072SEM	4	30"	762	72"	1829	101	45.8
T3084SEM	4	30"	762	84"	2134	116	52.6
T3096SEM	6	30"	762	96"	2438	139	63.1
T30108SEM	6	30"	762	108"	2743	161	73.0
T30120SEM	6	30"	762	120"	3048	182	82.6
T30132SEM	8	30"	762	132"	3353	204	92.5
T30144SEM	8	30"	762	144"	3658	224	101.6
T3648SEM	4	36"	914	48"	1219	83	37.6
T3660SEM	4	36"	914	60"	1524	97	44.0
T3672SEM	4	36"	914	72"	1829	114	51.7
T3684SEM	4	36"	914	84"	2134	132	59.9
T3696SEM	6	36"	914	96"	2438	153	69.4
T36108SEM	6	36"	914	108"	2743	180	81.6
T36120SEM	6	36"	914	120"	3048	207	93.9
T36132SEM	8	36"	914	132"	3353	234	106.1
T36144SEM	8	36"	914	144"	3658	261	118.4
T4848SEM	4	48"	1219	48"	1219	136	61.7
T4860SEM	4	48"	1219	60"	1524	161	73.0
T4872SEM	6	48"	1219	72"	1829	188	85.3
T4884SEM	8	48"	1219	84"	2134	217	98.4
T4896SEM	8	48"	1219	96"	2438	265	120.2
T48108SEM	8	48"	1219	108"	2743	306	138.8
T48120SEM	8	48"	1219	120"	3048	348	157.9
T48132SEM	8	48"	1219	132"	3353	388	176.0
T48144SEM	8	48"	1219	144"	3658	430	195.0





### Short Form Specifications

Top constructed of heavy gauge type 430 stainless steel with 1½" roll on front and rear, and sides turned down 90°. Open front with ¾" O.D. stainless steel tubular crossbracing on sides and rear. Top reinforced with welded hat channels and sound deadened. Constructed with uni-lok® patented gusset system with the gussets recessed into the hat channels to reduce lateral movement. Legs 1½" O.D., stainless steel tubing with stainless steel gussets and 1" stainless steel adjustable bullet feet.



worktable with flat top and tubular base  
—shown with optional drawer

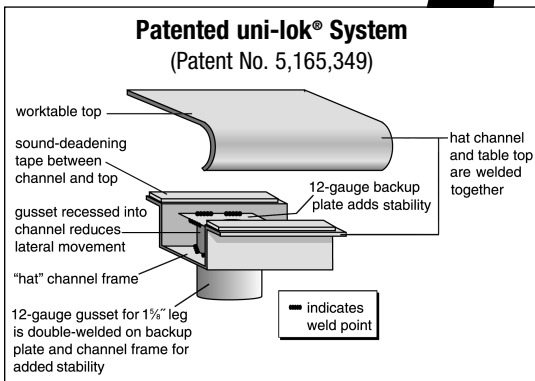

### MODELS:

- |                                   |                                    |                                    |                                    |
|-----------------------------------|------------------------------------|------------------------------------|------------------------------------|
| <input type="checkbox"/> T2424STB | <input type="checkbox"/> T24108STB | <input type="checkbox"/> T3072STB  | <input type="checkbox"/> T3660STB  |
| <input type="checkbox"/> T2430STB | <input type="checkbox"/> T24120STB | <input type="checkbox"/> T3084STB  | <input type="checkbox"/> T3672STB  |
| <input type="checkbox"/> T2436STB | <input type="checkbox"/> T24132STB | <input type="checkbox"/> T3096STB  | <input type="checkbox"/> T3684STB  |
| <input type="checkbox"/> T2448STB | <input type="checkbox"/> T24144STB | <input type="checkbox"/> T30108STB | <input type="checkbox"/> T3696STB  |
| <input type="checkbox"/> T2460STB | <input type="checkbox"/> T3030STB  | <input type="checkbox"/> T30120STB | <input type="checkbox"/> T36108STB |
| <input type="checkbox"/> T2472STB | <input type="checkbox"/> T3036STB  | <input type="checkbox"/> T30132STB | <input type="checkbox"/> T36120STB |
| <input type="checkbox"/> T2484STB | <input type="checkbox"/> T3048STB  | <input type="checkbox"/> T30144STB | <input type="checkbox"/> T36132STB |
| <input type="checkbox"/> T2496STB | <input type="checkbox"/> T3060STB  | <input type="checkbox"/> T3648STB  | <input type="checkbox"/> T36144STB |

### Tabletop

- Patented uni-lok® gusset system (patent #5,165,349): gussets are recessed into hat channel, reducing lateral movement.
- Top reinforced with welded-on hat channel.
- Sound-deadened between top and channels.
- 1½" (38mm)-diameter 180° rolled edges on front and rear. Ends are turned down 90°, providing for flush installations when required.
- Heavy gauge type 430 polished stainless steel.

### Crossbracing—1¼" (38mm)-diameter

- Heavy gauge stainless steel.
- Aluminum castings join crossbraces, legs and rear brace.

### Legs—1½" (41mm)-diameter

- Tables 96" (2438mm) and longer come with six legs or more.
- Heavy gauge stainless steel.
- 1" (25mm) adjustable stainless steel feet.

### Options / Accessories

- |  |  |
|--|--|
| <input type="checkbox"/> Drawer                                | <input type="checkbox"/> Duplex receptacles                            |
| <input type="checkbox"/> Lock                                  | <input type="checkbox"/> Pot rack                                      |
| <input type="checkbox"/> Casters                               | <input type="checkbox"/> Sink  |
| <input type="checkbox"/> Overshelves                           | <input type="checkbox"/> Stabilizer Bar (for 30"- and 36"-wide tables) |
| <input type="checkbox"/> Knockdown Welded Base (see back page) |  |





\*\*For custom sizes - fill in required dimensions in layout provided

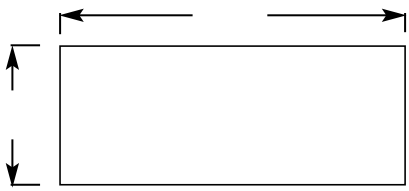

TOP VIEW

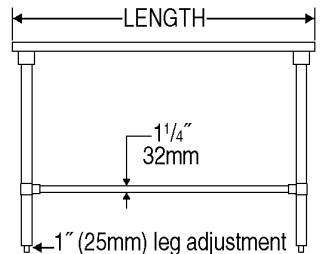

FRONT VIEW

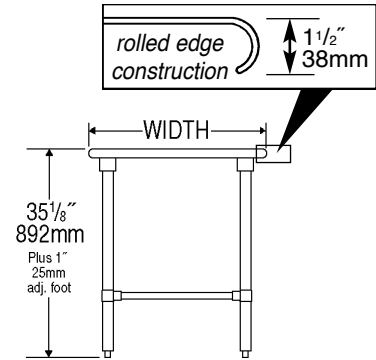

SIDE VIEW

model #	# of legs	width		length		weight	
		in.	mm	in.	mm	lbs.	kg
T2424STB	4	24"	610	24"	610	40	18.1
T2430STB	4	24"	610	30"	762	45	20.4
T2436STB	4	24"	610	36"	914	50	22.7
T2448STB	4	24"	610	48"	1219	60	27.2
T2460STB	4	24"	610	60"	1524	70	31.8
T2472STB	4	24"	610	72"	1829	80	36.3
T2484STB	4	24"	610	84"	2134	90	40.8
T2496STB	6	24"	610	96"	2438	100	45.4
T24108STB	6	24"	610	108"	2743	110	49.9
T24120STB	6	24"	610	120"	3048	120	54.4
T24132STB	8	24"	610	132"	3353	130	59.0
T24144STB	8	24"	610	144"	3658	140	63.5
T3030STB	4	30"	762	30"	762	47	21.3
T3036STB	4	30"	762	36"	914	53	24.0
T3048STB	4	30"	762	48"	1219	65	29.5
T3060STB	4	30"	762	60"	1524	77	34.9
T3072STB	4	30"	762	72"	1829	89	40.4
T3084STB	4	30"	762	84"	2134	101	45.8
T3096STB	6	30"	762	96"	2438	113	51.3
T30108STB	6	30"	762	108"	2743	125	56.7
T30120STB	6	30"	762	120"	3048	137	62.1
T30132STB	8	30"	762	132"	3353	149	67.6
T30144STB	8	30"	762	144"	3658	161	73.0
T3648STB	4	36"	914	48"	1219	73	33.1
T3660STB	4	36"	914	60"	1524	87	39.5
T3672STB	4	36"	914	72"	1829	101	45.8
T3684STB	4	36"	914	84"	2134	115	52.2
T3696STB	6	36"	914	96"	2438	129	58.5
T36108STB	6	36"	914	108"	2743	143	64.9
T36120STB	6	36"	914	120"	3048	157	71.2
T36132STB	8	36"	914	132"	3353	171	77.6
T36144STB	8	36"	914	144"	3658	185	83.9

**NEW Option for Worktables with Stainless Steel Base: Knockdown Welded Base**

**PATENT PENDING**



worktable shown with base knocked down



worktable assembled

- Precision machined stainless steel threaded inserts pressed into 16 gauge 1 5/8"-diameter leg sections for knockdown construction
- C-Frame stainless steel tubular base

Add suffix "-KDWB" to worktable model number (ex: T2436STB-KDWB). See EG8217 for more info.



### Short Form Specifications

Top constructed of 16 gauge 300 series stainless steel with 1½" roll on front and rear, and sides turned down 90°. Open front with ¾" O.D. stainless steel tubular crossbracing on sides and rear. Top reinforced with welded hat channels and sound deadened. Constructed with uni-lok® patented gusset system with the gussets recessed into the hat channels to reduce lateral movement. Legs are 1½" O.D. stainless steel tubing, with stainless steel gussets and 1" stainless steel adjustable bullet feet.



worktable with flat top and tubular base  
—shown with optional drawer

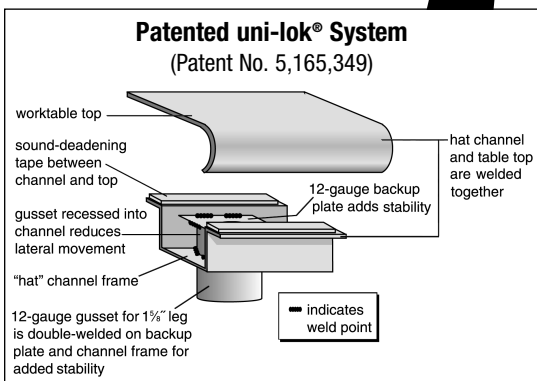

### MODELS:

- T2424STEB     T24108STEB     T3072STEB     T3660STEB
- T2430STEB     T24120STEB     T3084STEB     T3672STEB
- T2436STEB     T24132STEB     T3096STEB     T3684STEB
- T2448STEB     T24144STEB     T30108STEB     T3696STEB
- T2460STEB     T3030STEB     T30120STEB     T36108STEB
- T2472STEB     T3036STEB     T30132STEB     T36120STEB
- T2484STEB     T3048STEB     T30144STEB     T36132STEB
- T2496STEB     T3060STEB     T3648STEB     T36144STEB

### Tabletop

- Patented uni-lok® gusset system (patent #5,165,349): gussets are recessed into hat channel, reducing lateral movement.
- Top reinforced with welded-on hat channel.
- Sound-deadened between top and channels.
- 1½" (38mm)-diameter 180° rolled edges on front and rear. Ends are turned down 90°, providing for flush installations when required.
- 16 gauge 300 series polished stainless steel.

### Crossbracing—1¼" (38mm)-diameter

- Heavy gauge stainless steel.
- Aluminum castings join crossbraces, legs and rear brace.

### Legs—1½" (41mm)-diameter

- Tables 96" (2438mm) and longer come with six legs or more.
- Heavy gauge stainless steel.
- 1" (25mm) adjustable stainless steel feet.

### Options / Accessories

- Drawer
- Lock
- Casters
- Overshelves
- Knockdown Welded Base (see back page)
- Duplex receptacles
- Pot rack
- Sink
- Stabilizer Bar (for 30"- and 36"-wide tables)



\*\*For custom sizes - fill in required dimensions in layout provided

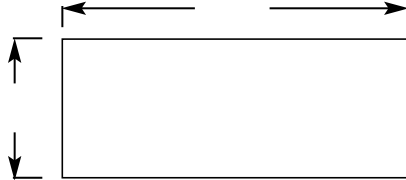

TOP VIEW

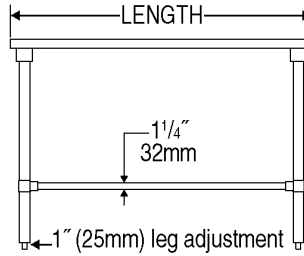

FRONT VIEW

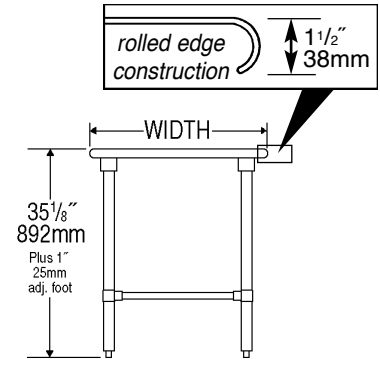

SIDE VIEW

model #	# of legs	width		length		weight	
		in.	mm	in.	mm	lbs.	kg
T2424STEB	4	24"	610	24"	610	40	18.1
T2430STEB	4	24"	610	30"	762	45	20.4
T2436STEB	4	24"	610	36"	914	50	22.7
T2448STEB	4	24"	610	48"	1219	60	27.2
T2460STEB	4	24"	610	60"	1524	70	31.8
T2472STEB	4	24"	610	72"	1829	80	36.3
T2484STEB	4	24"	610	84"	2134	90	40.8
T2496STEB	6	24"	610	96"	2438	100	45.4
T24108STEB	6	24"	610	108"	2743	110	49.9
T24120STEB	6	24"	610	120"	3048	120	54.4
T24132STEB	8	24"	610	132"	3353	130	59.0
T24144STEB	8	24"	610	144"	3658	140	63.5
T3030STEB	4	30"	762	30"	762	47	21.3
T3036STEB	4	30"	762	36"	914	53	24.0
T3048STEB	4	30"	762	48"	1219	65	29.5
T3060STEB	4	30"	762	60"	1524	77	34.9
T3072STEB	4	30"	762	72"	1829	89	40.4
T3084STEB	4	30"	762	84"	2134	101	45.8
T3096STEB	6	30"	762	96"	2438	113	51.3
T30108STEB	6	30"	762	108"	2743	125	56.7
T30120STEB	6	30"	762	120"	3048	137	62.1
T30132STEB	8	30"	762	132"	3353	149	67.6
T30144STEB	8	30"	762	144"	3658	161	73.0
T3648STEB	4	36"	914	48"	1219	73	33.1
T3660STEB	4	36"	914	60"	1524	87	39.5
T3672STEB	4	36"	914	72"	1829	101	45.8
T3684STEB	4	36"	914	84"	2134	115	52.2
T3696STEB	6	36"	914	96"	2438	129	58.5
T36108STEB	6	36"	914	108"	2743	143	64.9
T36120STEB	6	36"	914	120"	3048	157	71.2
T36132STEB	8	36"	914	132"	3353	171	77.6
T36144STEB	8	36"	914	144"	3658	185	83.9

**NEW Option for Worktables with Stainless Steel Base: Knockdown Welded Base**

**PATENT PENDING**



worktable shown with base knocked down



worktable assembled

- Precision machined stainless steel threaded inserts pressed into 16 gauge 1 5/8"-diameter leg sections for knockdown construction
- C-Frame stainless steel tubular base

Add suffix "**-KDWB**" to worktable model number (ex: T2436STEB-KDWB). See EG8217 for more info.



## Short Form Specifications

Top to be constructed of 14/304 stainless steel with 1½" roll on front and rear, and sides turned down 90°. Open front with 1¼" O.D. stainless steel tubular crossbracing on sides and rear. Top reinforced with welded hat channels and sound deadened.

Constructed with uni-lok® patented gusset system with the gussets recessed into the hat channels to reduce lateral movement. Legs to be 1½" O.D. stainless steel tubing, with stainless steel gussets and 1" stainless steel adjustable bullet feet.



worktable with flat top and tubular base  
—shown with optional drawer

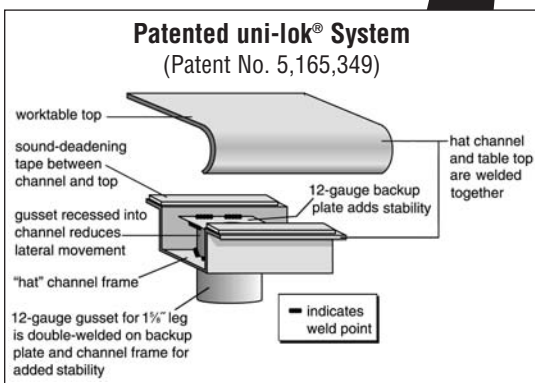

## MODELS:

- |                                    |                                    |                                    |                                    |
|------------------------------------|------------------------------------|------------------------------------|------------------------------------|
| <input type="checkbox"/> T2424STE  | <input type="checkbox"/> T24144STE | <input type="checkbox"/> T30132STE | <input type="checkbox"/> T36144STE |
| <input type="checkbox"/> T2430STE  | <input type="checkbox"/> T3030STE  | <input type="checkbox"/> T30144STE | <input type="checkbox"/> T4848STE  |
| <input type="checkbox"/> T2436STE  | <input type="checkbox"/> T3036STE  | <input type="checkbox"/> T3648STE  | <input type="checkbox"/> T4860STE  |
| <input type="checkbox"/> T2448STE  | <input type="checkbox"/> T3048STE  | <input type="checkbox"/> T3660STE  | <input type="checkbox"/> T4872STE  |
| <input type="checkbox"/> T2460STE  | <input type="checkbox"/> T3060STE  | <input type="checkbox"/> T3672STE  | <input type="checkbox"/> T4884STE  |
| <input type="checkbox"/> T2472STE  | <input type="checkbox"/> T3072STE  | <input type="checkbox"/> T3684STE  | <input type="checkbox"/> T4896STE  |
| <input type="checkbox"/> T2484STE  | <input type="checkbox"/> T3084STE  | <input type="checkbox"/> T3696STE  | <input type="checkbox"/> T48108STE |
| <input type="checkbox"/> T2496STE  | <input type="checkbox"/> T3096STE  | <input type="checkbox"/> T36108STE | <input type="checkbox"/> T48120STE |
| <input type="checkbox"/> T24108STE | <input type="checkbox"/> T30108STE | <input type="checkbox"/> T36120STE | <input type="checkbox"/> T48132STE |
| <input type="checkbox"/> T24120STE | <input type="checkbox"/> T30120STE | <input type="checkbox"/> T36132STE | <input type="checkbox"/> T48144STE |
| <input type="checkbox"/> T24132STE |                                    |                                    |                                    |

## Tabletop

- Patented uni-lok® gusset system (patent #5,165,349): gussets are recessed into hat channel, reducing lateral movement.
- Top reinforced with welded-on hat channel.
- Sound-deadened between top and channels.
- 1½" (38mm)-diameter 180° rolled edges on front and rear. Ends are turned down 90°, providing for flush installations when required.
- 14 gauge type 304 polished stainless steel.

## Crossbracing—1¼" (38mm)-diameter

- Heavy gauge stainless steel.
- Aluminum castings join crossbraces, legs and rear brace.

## Legs—1½" (41mm)-diameter

- 24" to 36" (610 to 914mm)-wide units that are 96" (2438mm) and longer come with six legs or more. 48" (1219mm)-wide units that are 72" (1829mm) and longer come with six legs or more.
- Heavy gauge stainless steel.
- 1" (25mm) adjustable stainless steel feet.

## Options / Accessories

- |  |  |
|--|--|
| <input type="checkbox"/> Drawer                      | <input type="checkbox"/> Duplex receptacles                            |
| <input type="checkbox"/> Lock                        | <input type="checkbox"/> Pot rack                                      |
| <input type="checkbox"/> Casters                     | <input type="checkbox"/> Sink  |
| <input type="checkbox"/> Stainless steel bullet feet | <input type="checkbox"/> Stabilizer Bar (for 30"- and 36"-wide tables) |
| <input type="checkbox"/> Overshelves                 |  |



\*\*For custom sizes - fill in required dimensions in layout provided

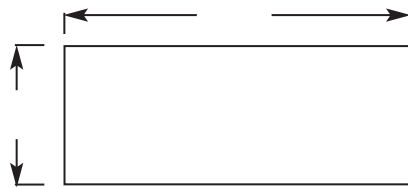

TOP VIEW

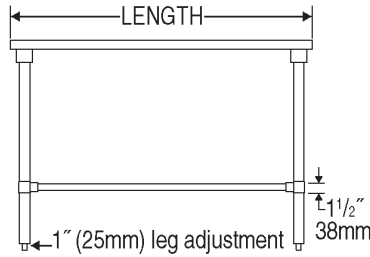

FRONT VIEW

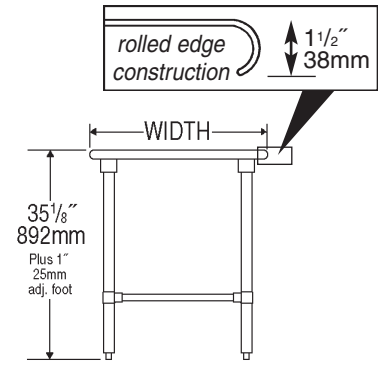

SIDE VIEW

model #	# of legs	width		length		weight	
		in.	mm	in.	mm	lbs.	kg
T2424STE	4	24"	610	24"	610	44	20.0
T2430STE	4	24"	610	30"	762	48	21.8
T2436STE	4	24"	610	36"	914	55	24.9
T2448STE	4	24"	610	48"	1219	66	29.9
T2460STE	4	24"	610	60"	1524	77	34.9
T2472STE	4	24"	610	72"	1829	88	39.9
T2484STE	4	24"	610	84"	2134	99	44.9
T2496STE	6	24"	610	96"	2438	110	49.9
T24108STE	6	24"	610	108"	2743	121	54.9
T24120STE	6	24"	610	120"	3048	132	59.9
T24132STE	8	24"	610	132"	3353	145	65.8
T24144STE	8	24"	610	144"	3658	154	69.9
T3030STE	4	30"	762	30"	762	52	23.6
T3036STE	4	30"	762	36"	914	58	26.3
T3048STE	4	30"	762	48"	1219	72	32.7
T3060STE	4	30"	762	60"	1524	85	38.6
T3072STE	4	30"	762	72"	1829	98	44.5
T3084STE	4	30"	762	84"	2134	111	50.3
T3096STE	6	30"	762	96"	2438	124	56.2
T30108STE	6	30"	762	108"	2743	138	62.6
T30120STE	6	30"	762	120"	3048	151	68.5
T30132STE	8	30"	762	132"	3353	164	74.4
T30144STE	8	30"	762	144"	3658	177	80.3
T3648STE	4	36"	914	48"	1219	80	36.3
T3660STE	4	36"	914	60"	1524	96	43.6
T3672STE	4	36"	914	72"	1829	111	50.3
T3684STE	4	36"	914	84"	2134	127	57.6
T3696STE	6	36"	914	96"	2438	142	64.4
T36108STE	6	36"	914	108"	2743	157	71.2
T36120STE	6	36"	914	120"	3048	172	78.0
T36132STE	8	36"	914	132"	3353	188	85.3
T36144STE	8	36"	914	144"	3658	204	92.5
T4848STE	4	48"	1219	48"	1219	96	43.6
T4860STE	4	48"	1219	60"	1524	111	50.3
T4872STE	6	48"	1219	72"	1829	127	57.6
T4884STE	8	48"	1219	84"	2134	132	59.9
T4896STE	8	48"	1219	96"	2438	157	71.2
T48108STE	8	48"	1219	108"	2743	173	78.5
T48120STE	8	48"	1219	120"	3048	188	85.3
T48132STE	8	48"	1219	132"	3353	204	92.5
T48144STE	8	48"	1219	144"	3658	219	99.3



## Short Form Specifications

Top to be constructed of 14/304 stainless steel with 2½" marine counter style edging on all four sides. Open front with 1¼" O.D., stainless steel tubular crossbracing on sides and rear. Top reinforced with welded hat channels and sound deadened. Constructed with uni-lok® patented gusset system with the gussets recessed into the hat channels to reduce lateral movement. Legs to be 1½" O.D. stainless steel tubing, with stainless steel gussets and 1" adjustable stainless steel bullet feet.



*worktable with flat top and tubular base*

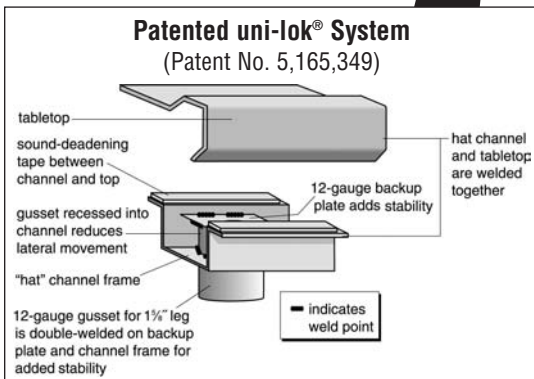

## MODELS:

- T2424STEM     T24144STEM     T30132STEM     T36144STEM
- T2430STEM     T3030STEM     T30144STEM     T4848STEM
- T2436STEM     T3036STEM     T3648STEM     T4860STEM
- T2448STEM     T3048STEM     T3660STEM     T4872STEM
- T2460STEM     T3060STEM     T3672STEM     T4884STEM
- T2472STEM     T3072STEM     T3684STEM     T4896STEM
- T2484STEM     T3084STEM     T3696STEM     T48108STEM
- T2496STEM     T3096STEM     T36108STEM     T48120STEM
- T24108STEM     T30108STEM     T36120STEM     T48132STEM
- T24120STEM     T30120STEM     T36132STEM     T48144STEM
- T24132STEM

## Tabletop

- Patented uni-lok® gusset system (patent #5,165,349): gussets are recessed into hat channel, reducing lateral movement.
- Top reinforced with welded-on hat channel.
- Sound-deadened between top and channels.
- Marine counter edge on all four sides.
- 14 gauge type 304 polished stainless steel.

## Crossbracing—1¼" (38mm)-diameter

- Heavy gauge stainless steel.
- Aluminum castings join crossbraces, legs and rear brace.

## Legs—1½" (41mm)-diameter

- 24" to 36" (610 to 914mm)-wide units that are 96" (2438mm) and longer come with six legs or more. 48" (1219mm)-wide units that are 72" (1829mm) and longer come with six legs or more.
- Heavy gauge stainless steel.
- 1" (25mm) adjustable stainless steel feet.

## Options / Accessories

- Drawer
- Lock
- Casters
- Stainless steel bullet feet
- Overshelves
- Duplex receptacles
- Pot rack
- Sink
- Stabilizer Bar (for 30"- and 36"-wide tables)





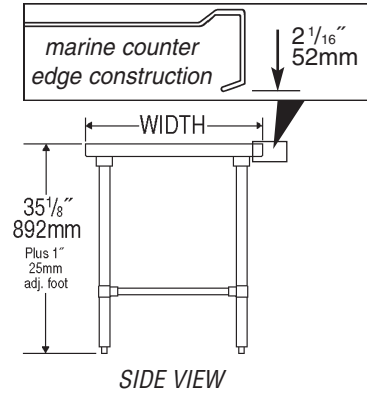
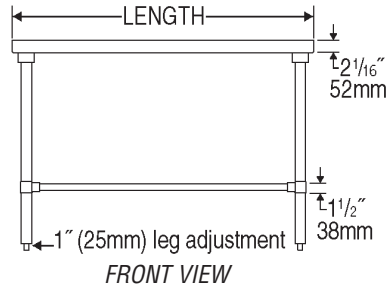
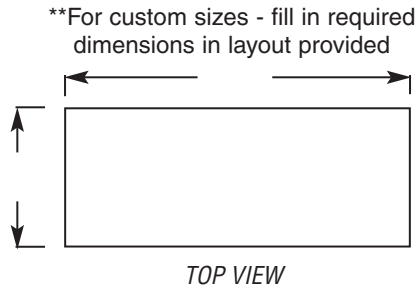

model #	# of legs	width		length		weight	
		in.	mm	in.	mm	lbs.	kg
T2424STEM	4	24"	610	24"	610	44	20.0
T2430STEM	4	24"	610	30"	762	48	21.8
T2436STEM	4	24"	610	36"	914	55	24.9
T2448STEM	4	24"	610	48"	1219	66	29.9
T2460STEM	4	24"	610	60"	1524	77	34.9
T2472STEM	4	24"	610	72"	1829	88	39.9
T2484STEM	4	24"	610	84"	2134	99	44.9
T2496STEM	6	24"	610	96"	2438	110	49.9
T24108STEM	6	24"	610	108"	2743	121	54.9
T24120STEM	6	24"	610	120"	3048	132	59.9
T24132STEM	8	24"	610	132"	3353	145	65.8
T24144STEM	8	24"	610	144"	3658	154	69.9
T3030STEM	4	30"	762	30"	762	52	23.6
T3036STEM	4	30"	762	36"	914	58	26.3
T3048STEM	4	30"	762	48"	1219	72	32.7
T3060STEM	4	30"	762	60"	1524	85	38.6
T3072STEM	4	30"	762	72"	1829	98	44.5
T3084STEM	4	30"	762	84"	2134	111	50.3
T3096STEM	6	30"	762	96"	2438	124	56.2
T30108STEM	6	30"	762	108"	2743	138	62.6
T30120STEM	6	30"	762	120"	3048	151	68.5
T30132STEM	8	30"	762	132"	3353	164	74.4
T30144STEM	8	30"	762	144"	3658	177	80.3
T3648STEM	4	36"	914	48"	1219	80	36.3
T3660STEM	4	36"	914	60"	1524	96	43.6
T3672STEM	4	36"	914	72"	1829	111	50.3
T3684STEM	4	36"	914	84"	2134	127	57.6
T3696STEM	6	36"	914	96"	2438	142	64.4
T36108STEM	6	36"	914	108"	2743	157	71.2
T36120STEM	6	36"	914	120"	3048	172	78.0
T36132STEM	8	36"	914	132"	3353	188	85.3
T36144STEM	8	36"	914	144"	3658	204	92.5
T4848STEM	4	48"	1219	48"	1219	96	43.6
T4860STEM	4	48"	1219	60"	1524	111	50.3
T4872STEM	6	48"	1219	72"	1829	127	57.6
T4884STEM	8	48"	1219	84"	2134	132	59.9
T4896STEM	8	48"	1219	96"	2438	157	71.2
T48108STEM	8	48"	1219	108"	2743	173	78.5
T48120STEM	8	48"	1219	120"	3048	188	85.3
T48132STEM	8	48"	1219	132"	3353	204	92.5
T48144STEM	8	48"	1219	144"	3658	219	99.3





## Short Form Specifications

Top constructed of heavy gauge type 430 stainless steel with 1½" roll on front, 4½" backsplash, and sides turned down 90°. Adjustable undershelf constructed of heavy gauge type 430 stainless steel with marine edge. Top reinforced with hat channels and sound deadened. Constructed with uni-lok® patented gusset system with the gussets recessed to reduce lateral movement. 1½"-diameter stainless steel legs, with galvanized gussets and 1" stainless steel adjustable bullet feet.

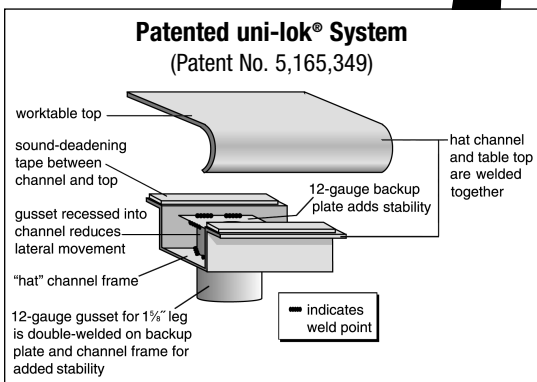

## MODELS:

- |                                     |                                      |                                      |                                      |
|-------------------------------------|--------------------------------------|--------------------------------------|--------------------------------------|
| <input type="checkbox"/> T2424SB-BS | <input type="checkbox"/> T24108SB-BS | <input type="checkbox"/> T3072SB-BS  | <input type="checkbox"/> T3660SB-BS  |
| <input type="checkbox"/> T2430SB-BS | <input type="checkbox"/> T24120SB-BS | <input type="checkbox"/> T3084SB-BS  | <input type="checkbox"/> T3672SB-BS  |
| <input type="checkbox"/> T2436SB-BS | <input type="checkbox"/> T24132SB-BS | <input type="checkbox"/> T3096SB-BS  | <input type="checkbox"/> T3684SB-BS  |
| <input type="checkbox"/> T2448SB-BS | <input type="checkbox"/> T24144SB-BS | <input type="checkbox"/> T30108SB-BS | <input type="checkbox"/> T3696SB-BS  |
| <input type="checkbox"/> T2460SB-BS | <input type="checkbox"/> T3030SB-BS  | <input type="checkbox"/> T30120SB-BS | <input type="checkbox"/> T36108SB-BS |
| <input type="checkbox"/> T2472SB-BS | <input type="checkbox"/> T3036SB-BS  | <input type="checkbox"/> T30132SB-BS | <input type="checkbox"/> T36120SB-BS |
| <input type="checkbox"/> T2484SB-BS | <input type="checkbox"/> T3048SB-BS  | <input type="checkbox"/> T30144SB-BS | <input type="checkbox"/> T36132SB-BS |
| <input type="checkbox"/> T2496SB-BS | <input type="checkbox"/> T3060SB-BS  | <input type="checkbox"/> T3648SB-BS  | <input type="checkbox"/> T36144SB-BS |

## Tabletop

- Patented uni-lok® gusset system (patent #5,165,349): gussets are recessed into hat channel, reducing lateral movement.
- Top reinforced with welded-on hat channel.
- Sound-deadened between top and channels.
- 4½" (114mm)-high 90° backsplash with 1" (25mm) turn at 90°.
- 1½" (38mm)-diameter 180° rolled edge on front. Ends are turned down 90°, providing for flush installations when required.
- Heavy gauge type 430 polished stainless steel.

## Adjustable Undershelf

- Heavy gauge stainless steel.
- Gusset welded to each corner.
- Heavy duty marine edge design.

## Legs—1½" (41mm)-diameter

- Tables 96" (2438mm) and longer come with six legs or more.
- Heavy gauge stainless steel.
- 1" (25mm) adjustable stainless steel feet.

## Options / Accessories

- |  |  |
|--|--|
| <input type="checkbox"/> Drawer                                | <input type="checkbox"/> Duplex receptacles                            |
| <input type="checkbox"/> Lock                                  | <input type="checkbox"/> Pot rack                                      |
| <input type="checkbox"/> Casters                               | <input type="checkbox"/> Sink  |
| <input type="checkbox"/> Overshelves                           | <input type="checkbox"/> Additional undershelf                         |
| <input type="checkbox"/> Power strip (for material handling)   | <input type="checkbox"/> Stabilizer Bar (for 30"- and 36"-wide tables) |
| <input type="checkbox"/> Knockdown Welded Base (see back page) |  |



\*\*For custom sizes - fill in required dimensions in layout provided

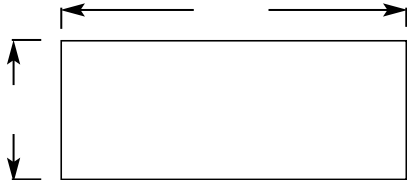

TOP VIEW

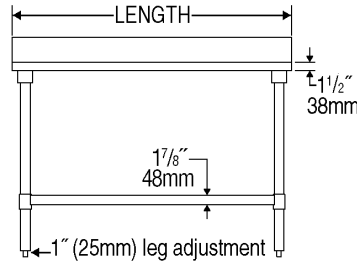

FRONT VIEW

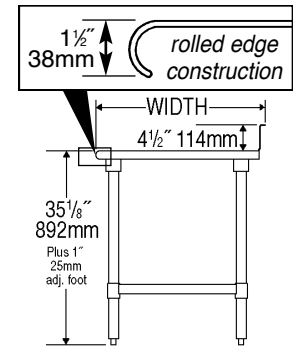

SIDE VIEW

model #	# of legs	width		length		weight	
		in.	mm	in.	mm	lbs.	kg
T2424SB-BS	4	24"	610	24"	610	44	20.0
T2430SB-BS	4	24"	610	30"	762	51	23.1
T2436SB-BS	4	24"	610	36"	914	53	24.0
T2448SB-BS	4	24"	610	48"	1219	67	30.4
T2460SB-BS	4	24"	610	60"	1524	79	35.8
T2472SB-BS	4	24"	610	72"	1829	94	42.6
T2484SB-BS	4	24"	610	84"	2134	132	59.9
T2496SB-BS	6	24"	610	96"	2438	137	62.1
T24108SB-BS	6	24"	610	108"	2743	142	64.4
T24120SB-BS	6	24"	610	120"	3048	154	69.9
T24132SB-BS	8	24"	610	132"	3353	177	80.3
T24144SB-BS	8	24"	610	144"	3658	234	106.1
T3030SB-BS	4	30"	762	30"	762	55	25.0
T3036SB-BS	4	30"	762	36"	914	62	28.2
T3048SB-BS	4	30"	762	48"	1219	77	34.9
T3060SB-BS	4	30"	762	60"	1524	87	39.5
T3072SB-BS	4	30"	762	72"	1829	105	47.6
T3084SB-BS	4	30"	762	84"	2134	132	59.9
T3096SB-BS	6	30"	762	96"	2438	169	76.7
T30108SB-BS	6	30"	762	108"	2743	176	79.8
T30120SB-BS	6	30"	762	120"	3048	182	82.6
T30132SB-BS	8	30"	762	132"	3353	225	102.0
T30144SB-BS	8	30"	762	144"	3658	238	107.6
T3648SB-BS	4	36"	914	48"	1219	84	38.1
T3660SB-BS	4	36"	914	60"	1524	99	44.9
T3672SB-BS	4	36"	914	72"	1829	114	51.7
T3684SB-BS	4	36"	914	84"	2134	183	83.0
T3696SB-BS	6	36"	914	96"	2438	203	92.0
T36108SB-BS	6	36"	914	108"	2743	207	93.9
T36120SB-BS	6	36"	914	120"	3048	211	95.7
T36132SB-BS	8	36"	914	132"	3353	234	106.1
T36144SB-BS	8	36"	914	144"	3658	241	109.3

**NEW Option for Worktables with Stainless Steel Base: Knockdown Welded Base**

**PATENT PENDING**



worktable shown with base knocked down



worktable assembled

- Precision machined stainless steel threaded inserts pressed into 16 gauge 1 5/8"-diameter leg sections for knockdown construction
- Marine edge stainless steel undershelf welded to lower leg sections

Add suffix **"-KDWB"** to worktable model number (ex: T2436SB-BS-KDWB). See EG8217 for more info.



## Short Form Specifications

Top constructed of 16 gauge 300 series stainless steel with 1½" roll on front, 4½" backsplash, and sides turned down 90°. Adjustable undershelf constructed of heavy gauge type 430 stainless steel with marine edge. Top reinforced with hat channels and sound deadened. Constructed with uni-lok® patented gusset system with the gussets recessed into the hat channels to reduce lateral movement. 1½"-diameter stainless steel legs, with galvanized gussets and 1" stainless steel adjustable bullet feet.



*worktable with backsplash and adjustable undershelf*

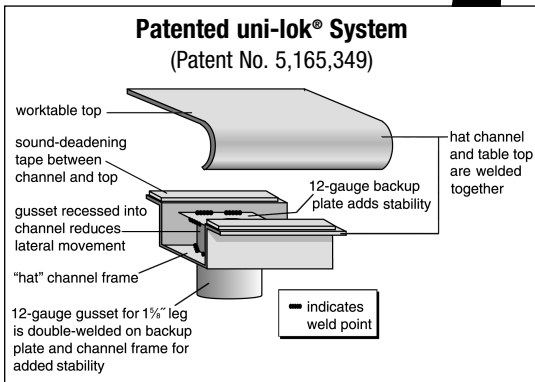

## MODELS:

- |                                      |                                       |                                       |                                       |
|--------------------------------------|---------------------------------------|---------------------------------------|---------------------------------------|
| <input type="checkbox"/> T2424SEB-BS | <input type="checkbox"/> T24108SEB-BS | <input type="checkbox"/> T3072SEB-BS  | <input type="checkbox"/> T3660SEB-BS  |
| <input type="checkbox"/> T2430SEB-BS | <input type="checkbox"/> T24120SEB-BS | <input type="checkbox"/> T3084SEB-BS  | <input type="checkbox"/> T3672SEB-BS  |
| <input type="checkbox"/> T2436SEB-BS | <input type="checkbox"/> T24132SEB-BS | <input type="checkbox"/> T3096SEB-BS  | <input type="checkbox"/> T3684SEB-BS  |
| <input type="checkbox"/> T2448SEB-BS | <input type="checkbox"/> T24144SEB-BS | <input type="checkbox"/> T30108SEB-BS | <input type="checkbox"/> T3696SEB-BS  |
| <input type="checkbox"/> T2460SEB-BS | <input type="checkbox"/> T3030SEB-BS  | <input type="checkbox"/> T30120SEB-BS | <input type="checkbox"/> T36108SEB-BS |
| <input type="checkbox"/> T2472SEB-BS | <input type="checkbox"/> T3036SEB-BS  | <input type="checkbox"/> T30132SEB-BS | <input type="checkbox"/> T36120SEB-BS |
| <input type="checkbox"/> T2484SEB-BS | <input type="checkbox"/> T3048SEB-BS  | <input type="checkbox"/> T30144SEB-BS | <input type="checkbox"/> T36132SEB-BS |
| <input type="checkbox"/> T2496SEB-BS | <input type="checkbox"/> T3060SEB-BS  | <input type="checkbox"/> T3648SEB-BS  | <input type="checkbox"/> T36144SEB-BS |

## Tabletop

- Patented uni-lok® gusset system (patent #5,165,349): gussets are recessed into hat channel, reducing lateral movement.
- Top reinforced with welded-on hat channel.
- Sound-deadened between top and channels.
- 4½" (114mm)-high 90° backsplash with 1" (25mm) turn at 90°.
- 1½" (38mm)-diameter 180° rolled edge on front. Ends are turned down 90°, providing for flush installations when required.
- 16 gauge 300 series polished stainless steel.

## Adjustable Undershelf

- Heavy gauge stainless steel.
- Gusset welded to each corner.
- Heavy duty marine edge design.

## Legs—1½" (41mm)-diameter

- Tables 96" (2438mm) and longer come with six legs or more.
- Heavy gauge stainless steel.
- 1" (25mm) adjustable stainless steel feet.

## Options / Accessories

- |  |  |
|--|--|
| <input type="checkbox"/> Drawer                                | <input type="checkbox"/> Duplex receptacles                            |
| <input type="checkbox"/> Lock                                  | <input type="checkbox"/> Pot rack                                      |
| <input type="checkbox"/> Casters                               | <input type="checkbox"/> Sink  |
| <input type="checkbox"/> Overshelves                           | <input type="checkbox"/> Additional undershelf                         |
| <input type="checkbox"/> Power strip (for material handling)   | <input type="checkbox"/> Stabilizer Bar (for 30"- and 36"-wide tables) |
| <input type="checkbox"/> Knockdown Welded Base (see back page) |  |



\*\*For custom sizes - fill in required dimensions in layout provided

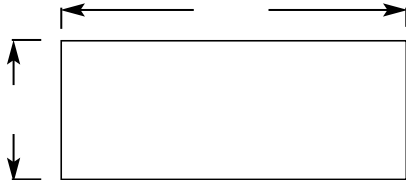

TOP VIEW

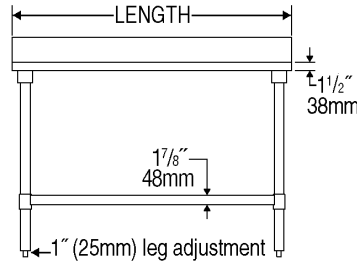

FRONT VIEW

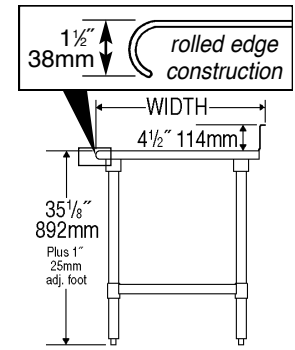

SIDE VIEW

model #	# of legs	width		length		weight	
		in.	mm	in.	mm	lbs.	kg
T2424SEB-BS	4	24"	610	24"	610	44	20.0
T2430SEB-BS	4	24"	610	30"	762	51	23.1
T2436SEB-BS	4	24"	610	36"	914	53	24.0
T2448SEB-BS	4	24"	610	48"	1219	67	30.4
T2460SEB-BS	4	24"	610	60"	1524	79	35.8
T2472SEB-BS	4	24"	610	72"	1829	94	42.6
T2484SEB-BS	4	24"	610	84"	2134	132	59.9
T2496SEB-BS	6	24"	610	96"	2438	137	62.1
T24108SEB-BS	6	24"	610	108"	2743	142	64.4
T24120SEB-BS	6	24"	610	120"	3048	154	69.9
T24132SEB-BS	8	24"	610	132"	3353	177	80.3
T24144SEB-BS	8	24"	610	144"	3658	234	106.1
T3030SEB-BS	4	30"	762	30"	762	55	25.0
T3036SEB-BS	4	30"	762	36"	914	62	28.2
T3048SEB-BS	4	30"	762	48"	1219	77	34.9
T3060SEB-BS	4	30"	762	60"	1524	87	39.5
T3072SEB-BS	4	30"	762	72"	1829	105	47.6
T3084SEB-BS	4	30"	762	84"	2134	132	59.9
T3096SEB-BS	6	30"	762	96"	2438	169	76.7
T30108SEB-BS	6	30"	762	108"	2743	176	79.8
T30120SEB-BS	6	30"	762	120"	3048	182	82.6
T30132SEB-BS	8	30"	762	132"	3353	225	102.0
T30144SEB-BS	8	30"	762	144"	3658	238	107.6
T3648SEB-BS	4	36"	914	48"	1219	84	38.1
T3660SEB-BS	4	36"	914	60"	1524	99	44.9
T3672SEB-BS	4	36"	914	72"	1829	114	51.7
T3684SEB-BS	4	36"	914	84"	2134	183	83.0
T3696SEB-BS	6	36"	914	96"	2438	203	92.0
T36108SEB-BS	6	36"	914	108"	2743	207	93.9
T36120SEB-BS	6	36"	914	120"	3048	211	95.7
T36132SEB-BS	8	36"	914	132"	3353	234	106.1
T36144SEB-BS	8	36"	914	144"	3658	241	109.3

**NEW Option for Worktables with Stainless Steel Base: Knockdown Welded Base**

**PATENT PENDING**



worktable shown with base knocked down



worktable assembled

- Precision machined stainless steel threaded inserts pressed into 16 gauge 1 5/8"-diameter leg sections for knockdown construction
- Marine edge stainless steel undershelf welded to lower leg sections

Add suffix **"-KDWB"** to worktable model number (ex: T2436SEB-BS-KDWB). See EG8217 for more info.



### Short Form Specifications

Top constructed of 14/304 stainless steel with 1½" roll on front, 4½" backsplash, and sides turned down 90°. Adjustable undershelf constructed of 18/304 stainless steel with marine edge. Top reinforced with stainless steel hat channels and sound deadened. Constructed with uni-lok® patented gusset system with the gussets recessed into the hat channels to reduce lateral movement. 1½"-diameter stainless steel legs, with stainless steel gussets and 1" stainless steel adjustable bullet feet.



*worktable with backsplash and adjustable undershelf*

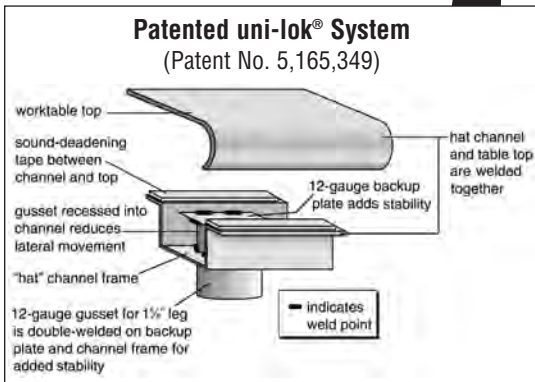

### MODELS:

- |                                     |                                      |                                      |                                      |
|-------------------------------------|--------------------------------------|--------------------------------------|--------------------------------------|
| <input type="checkbox"/> T2424SE-BS | <input type="checkbox"/> T24108SE-BS | <input type="checkbox"/> T3072SE-BS  | <input type="checkbox"/> T3660SE-BS  |
| <input type="checkbox"/> T2430SE-BS | <input type="checkbox"/> T24120SE-BS | <input type="checkbox"/> T3084SE-BS  | <input type="checkbox"/> T3672SE-BS  |
| <input type="checkbox"/> T2436SE-BS | <input type="checkbox"/> T24132SE-BS | <input type="checkbox"/> T3096SE-BS  | <input type="checkbox"/> T3684SE-BS  |
| <input type="checkbox"/> T2448SE-BS | <input type="checkbox"/> T24144SE-BS | <input type="checkbox"/> T30108SE-BS | <input type="checkbox"/> T3696SE-BS  |
| <input type="checkbox"/> T2460SE-BS | <input type="checkbox"/> T3030SE-BS  | <input type="checkbox"/> T30120SE-BS | <input type="checkbox"/> T36108SE-BS |
| <input type="checkbox"/> T2472SE-BS | <input type="checkbox"/> T3036SE-BS  | <input type="checkbox"/> T30132SE-BS | <input type="checkbox"/> T36120SE-BS |
| <input type="checkbox"/> T2484SE-BS | <input type="checkbox"/> T3048SE-BS  | <input type="checkbox"/> T30144SE-BS | <input type="checkbox"/> T36132SE-BS |
| <input type="checkbox"/> T2496SE-BS | <input type="checkbox"/> T3060SE-BS  | <input type="checkbox"/> T3648SE-BS  | <input type="checkbox"/> T36144SE-BS |

### Tabletop

- Patented uni-lok® gusset system (patent #5,165,349): gussets are recessed into hat channel, reducing lateral movement.
- Top reinforced with welded-on hat channel.
- Sound-deadened between top and channels.
- 4½" (114mm)-high 90° backsplash with 1" (25mm) turn at 90°.
- 1½" (38mm)-diameter 180° rolled edge on front. Ends are turned down 90°, providing for flush installations when required.
- 14 gauge type 304 polished stainless steel.

### Adjustable Undershelf

- Heavy gauge stainless steel.
- Gusset welded to each corner.
- Heavy duty marine edge design.

### Legs—1½" (41mm)-diameter

- Tables 96" (2438mm) and longer come with six legs or more.
- Heavy gauge stainless steel.
- 1" (25mm) adjustable stainless steel feet.

### Options / Accessories

- |  |  |
|--|--|
| <input type="checkbox"/> Drawer                              | <input type="checkbox"/> Duplex receptacles                            |
| <input type="checkbox"/> Lock                                | <input type="checkbox"/> Pot rack                                      |
| <input type="checkbox"/> Casters                             | <input type="checkbox"/> Sink  |
| <input type="checkbox"/> Stainless steel bullet feet         | <input type="checkbox"/> Additional undershelf                         |
| <input type="checkbox"/> Overshelves                         | <input type="checkbox"/> Stabilizer Bar (for 30"- and 36"-wide tables) |
| <input type="checkbox"/> Power strip (for material handling) |  |



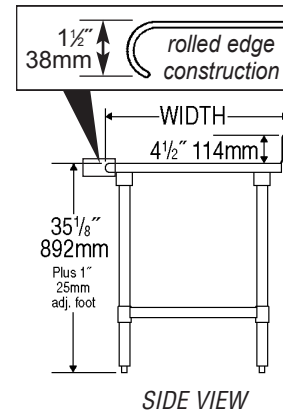
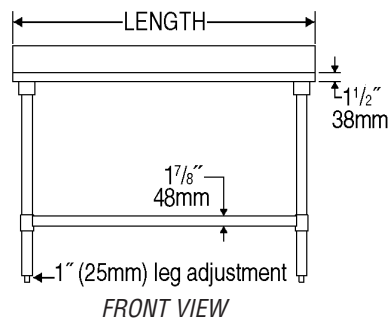
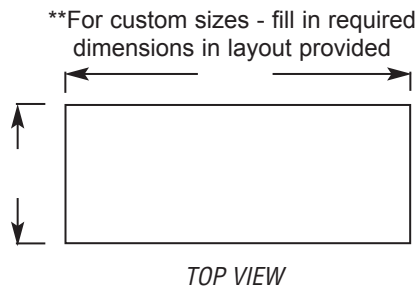

model #	# of legs	width		length		weight	
		in.	mm	in.	mm	lbs.	kg
T2424SE-BS	4	24"	610	24"	610	47	21.3
T2430SE-BS	4	24"	610	30"	762	53	24.0
T2436SE-BS	4	24"	610	36"	914	58	26.3
T2448SE-BS	4	24"	610	48"	1219	69	31.3
T2460SE-BS	4	24"	610	60"	1524	80	36.3
T2472SE-BS	4	24"	610	72"	1829	94	42.6
T2484SE-BS	4	24"	610	84"	2134	107	48.5
T2496SE-BS	6	24"	610	96"	2438	125	56.7
T24108SE-BS	6	24"	610	108"	2743	156	70.3
T24120SE-BS	6	24"	610	120"	3048	169	76.7
T24132SE-BS	8	24"	610	132"	3353	183	83.0
T24144SE-BS	8	24"	610	144"	3658	196	88.9
T3030SE-BS	4	30"	762	30"	762	55	24.9
T3036SE-BS	4	30"	762	36"	914	58	26.3
T3048SE-BS	4	30"	762	48"	1219	77	34.9
T3060SE-BS	4	30"	762	60"	1524	89	40.4
T3072SE-BS	4	30"	762	72"	1829	103	46.3
T3084SE-BS	4	30"	762	84"	2134	119	54.0
T3096SE-BS	6	30"	762	96"	2438	143	64.9
T30108SE-BS	6	30"	762	108"	2743	165	74.4
T30120SE-BS	6	30"	762	120"	3048	187	84.8
T30132SE-BS	8	30"	762	132"	3353	207	93.9
T30144SE-BS	8	30"	762	144"	3658	228	103.4
T3648SE-BS	4	36"	914	48"	1219	85	38.6
T3660SE-BS	4	36"	914	60"	1524	99	44.9
T3672SE-BS	4	36"	914	72"	1829	117	53.1
T3684SE-BS	4	36"	914	84"	2134	135	61.2
T3696SE-BS	6	36"	914	96"	2438	145	65.8
T36108SE-BS	6	36"	914	108"	2743	186	84.4
T36120SE-BS	6	36"	914	120"	3048	211	95.7
T36132SE-BS	8	36"	914	132"	3353	238	108.0
T36144SE-BS	8	36"	914	144"	3658	263	119.3





### Short Form Specifications

Top constructed of 14/304 stainless steel, with 2 1/16" marine counter style edging on all four sides and 4 1/2" backsplash. Adjustable undershelf constructed of 18/304 stainless steel with marine edge. Top reinforced with stainless steel hat channels and sound deadened. Constructed with uni-lok® patented gusset system with the gussets recessed into the hat channels to reduce lateral movement. 1 5/8"-diameter stainless steel legs, with stainless steel gussets and 1" stainless steel adjustable bullet feet.



*worktable with backsplash and adjustable undershelf*

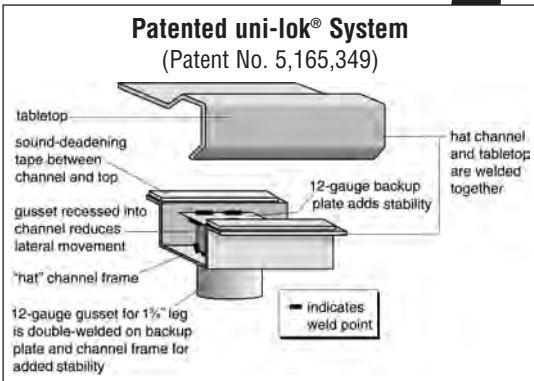

### MODELS:

- T2424SEM-BS     T24108SEM-BS     T3072SEM-BS     T3660SEM-BS
- T2430SEM-BS     T24120SEM-BS     T3084SEM-BS     T3672SEM-BS
- T2436SEM-BS     T24132SEM-BS     T3096SEM-BS     T3684SEM-BS
- T2448SEM-BS     T24144SEM-BS     T30108SEM-BS     T3696SEM-BS
- T2460SEM-BS     T3030SEM-BS     T30120SEM-BS     T36108SEM-BS
- T2472SEM-BS     T3036SEM-BS     T30132SEM-BS     T36120SEM-BS
- T2484SEM-BS     T3048SEM-BS     T30144SEM-BS     T36132SEM-BS
- T2496SEM-BS     T3060SEM-BS     T3648SEM-BS     T36144SEM-BS

### Tabletop

- Patented uni-lok® gusset system (patent #5,165,349): gussets are recessed into hat channel, reducing lateral movement.
- Top reinforced with welded-on hat channel.
- Sound-deadened between top and channels.
- 4 1/2" (114mm)-high 90° backsplash with 1" (25mm) turn at 90°.
- Marine counter edge on front and ends.
- 14 gauge type 304 polished stainless steel.

### Adjustable Undershelf

- Heavy gauge stainless steel.
- Gusset welded to each corner.
- Heavy duty marine edge design.

### Legs—1 5/8" (41mm)-diameter

- Tables 96" (2438mm) and longer come with six legs or more.
- Heavy gauge stainless steel.
- 1" (25mm) adjustable stainless steel feet.

### Options / Accessories

- Drawer
- Lock
- Casters
- Stainless steel bullet feet
- Overshelves
- Power strip (for material handling)
- Duplex receptacles
- Pot rack
- Sink
- Additional undershelf
- Stabilizer Bar (for 30"- and 36"-wide tables)





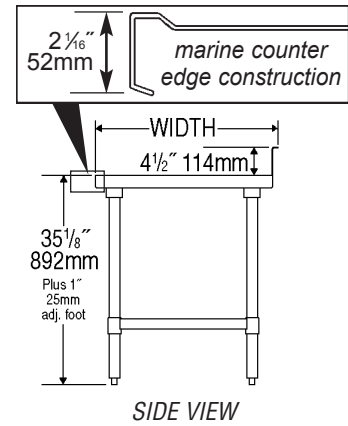
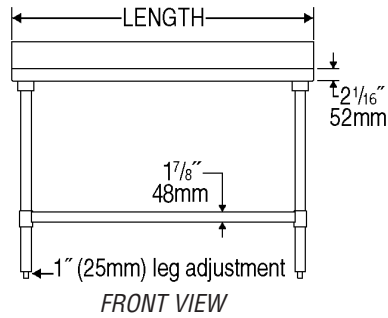
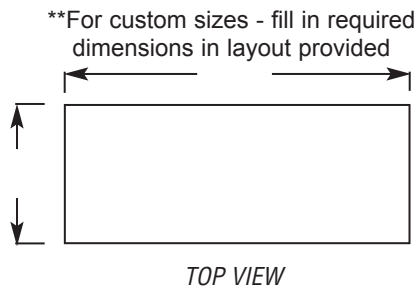

model #	# of legs	width		length		weight	
		in.	mm	in.	mm	lbs.	kg
T2424SEM-BS	4	24"	610	24"	610	47	21.3
T2430SEM-BS	4	24"	610	30"	762	53	24.0
T2436SEM-BS	4	24"	610	36"	914	58	26.3
T2448SEM-BS	4	24"	610	48"	1219	69	31.3
T2460SEM-BS	4	24"	610	60"	1524	80	36.3
T2472SEM-BS	4	24"	610	72"	1829	94	42.6
T2484SEM-BS	4	24"	610	84"	2134	107	48.5
T2496SEM-BS	6	24"	610	96"	2438	125	56.7
T24108SEM-BS	6	24"	610	108"	2743	156	70.3
T24120SEM-BS	6	24"	610	120"	3048	169	76.7
T24132SEM-BS	8	24"	610	132"	3353	183	83.0
T24144SEM-BS	8	24"	610	144"	3658	196	88.9
T3030SEM-BS	4	30"	762	30"	762	55	24.9
T3036SEM-BS	4	30"	762	36"	914	58	26.3
T3048SEM-BS	4	30"	762	48"	1219	77	34.9
T3060SEM-BS	4	30"	762	60"	1524	89	40.4
T3072SEM-BS	4	30"	762	72"	1829	103	46.3
T3084SEM-BS	4	30"	762	84"	2134	119	54.0
T3096SEM-BS	6	30"	762	96"	2438	143	64.9
T30108SEM-BS	6	30"	762	108"	2743	165	74.4
T30120SEM-BS	6	30"	762	120"	3048	187	84.8
T30132SEM-BS	8	30"	762	132"	3353	207	93.9
T30144SEM-BS	8	30"	762	144"	3658	228	103.4
T3648SEM-BS	4	36"	914	48"	1219	85	38.6
T3660SEM-BS	4	36"	914	60"	1524	99	44.9
T3672SEM-BS	4	36"	914	72"	1829	117	53.1
T3684SEM-BS	4	36"	914	84"	2134	135	61.2
T3696SEM-BS	6	36"	914	96"	2438	145	65.8
T36108SEM-BS	6	36"	914	108"	2743	186	84.4
T36120SEM-BS	6	36"	914	120"	3048	211	95.7
T36132SEM-BS	8	36"	914	132"	3353	238	108.0
T36144SEM-BS	8	36"	914	144"	3658	263	119.3



## Short Form Specifications

Top to be constructed of heavy gauge type 430 stainless steel with 1½" roll on front, 4½" backsplash, and sides turned down 90°. Open front with 1¼" O.D., stainless steel tubular crossbracing on sides and rear. Top reinforced with welded hat channels and sound deadened. Constructed with uni-lok® patented gusset system with the gussets recessed into the hat channels to reduce lateral movement. Legs to be 1½" O.D. stainless steel tubing, with stainless steel gussets and 1" stainless steel adjustable bullet feet.



*worktable with backsplash  
and tubular base  
—shown with optional drawer*

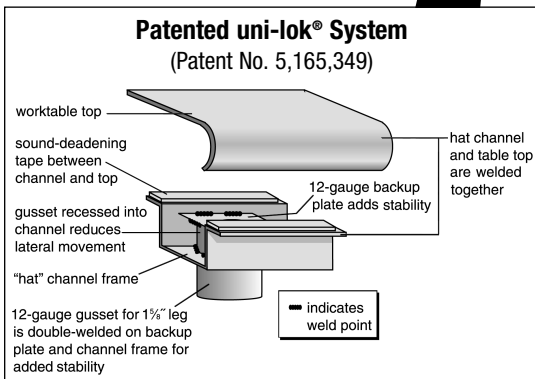

## MODELS:

- |                                      |                                       |                                       |                                       |
|--------------------------------------|---------------------------------------|---------------------------------------|---------------------------------------|
| <input type="checkbox"/> T2424STB-BS | <input type="checkbox"/> T24108STB-BS | <input type="checkbox"/> T3072STB-BS  | <input type="checkbox"/> T3660STB-BS  |
| <input type="checkbox"/> T2430STB-BS | <input type="checkbox"/> T24120STB-BS | <input type="checkbox"/> T3084STB-BS  | <input type="checkbox"/> T3672STB-BS  |
| <input type="checkbox"/> T2436STB-BS | <input type="checkbox"/> T24132STB-BS | <input type="checkbox"/> T3096STB-BS  | <input type="checkbox"/> T3684STB-BS  |
| <input type="checkbox"/> T2448STB-BS | <input type="checkbox"/> T24144STB-BS | <input type="checkbox"/> T30108STB-BS | <input type="checkbox"/> T3696STB-BS  |
| <input type="checkbox"/> T2460STB-BS | <input type="checkbox"/> T3030STB-BS  | <input type="checkbox"/> T30120STB-BS | <input type="checkbox"/> T36108STB-BS |
| <input type="checkbox"/> T2472STB-BS | <input type="checkbox"/> T3036STB-BS  | <input type="checkbox"/> T30132STB-BS | <input type="checkbox"/> T36120STB-BS |
| <input type="checkbox"/> T2484STB-BS | <input type="checkbox"/> T3048STB-BS  | <input type="checkbox"/> T30144STB-BS | <input type="checkbox"/> T36132STB-BS |
| <input type="checkbox"/> T2496STB-BS | <input type="checkbox"/> T3060STB-BS  | <input type="checkbox"/> T3648STB-BS  | <input type="checkbox"/> T36144STB-BS |

## Tabletop

- Patented uni-lok® gusset system (patent #5,165,349): gussets are recessed into hat channel, reducing lateral movement.
- Top reinforced with welded-on hat channel.
- Sound-deadened between top and channels.
- 4½" (114mm)-high 90° backsplash with 1" (25mm) turn at 90°.
- 1½" (38mm)-diameter 180° rolled edge on front. Ends are turned down 90°, providing for flush installations when required.
- Heavy gauge type 430 polished stainless steel.

## Crossbracing—1¼" (38mm)-diameter

- Heavy gauge stainless steel.
- Aluminum castings join crossbraces, legs and rear brace.

## Legs—1½" (41mm)-diameter

- Tables 96" (2438mm) and longer come with six legs or more.
- Heavy gauge stainless steel.
- 1" (25mm) adjustable stainless steel feet.

## Options / Accessories

- |   |   |
|---|---|
| <input type="checkbox"/> Drawer                                   | <input type="checkbox"/> Duplex receptacles                               |
| <input type="checkbox"/> Lock                                     | <input type="checkbox"/> Overshelves                                      |
| <input type="checkbox"/> Casters                                  | <input type="checkbox"/> Pot rack   |
| <input type="checkbox"/> Power strip (for material handling)      | <input type="checkbox"/> Sink   |
| <input type="checkbox"/> Knockdown Welded Base<br>(see back page) | <input type="checkbox"/> Stabilizer Bar (for 30"-<br>and 36"-wide tables) |



\*\*For custom sizes - fill in required dimensions in layout provided

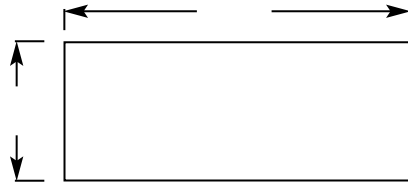

TOP VIEW

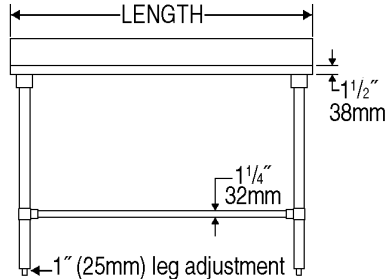

FRONT VIEW

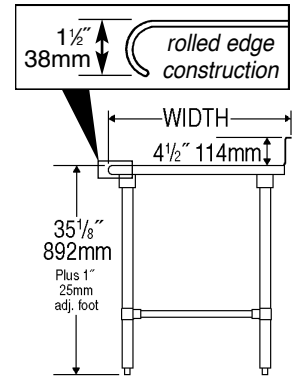

SIDE VIEW

model #	# of legs	width		length		weight	
		in.	mm	in.	mm	lbs.	kg
T2424STB-BS	4	24"	610	24"	610	41	18.6
T2430STB-BS	4	24"	610	30"	762	46	20.9
T2436STB-BS	4	24"	610	36"	914	51	23.1
T2448STB-BS	4	24"	610	48"	1219	61	27.7
T2460STB-BS	4	24"	610	60"	1524	71	32.2
T2472STB-BS	4	24"	610	72"	1829	81	36.7
T2484STB-BS	4	24"	610	84"	2134	91	41.3
T2496STB-BS	6	24"	610	96"	2438	101	45.8
T24108STB-BS	6	24"	610	108"	2743	111	50.3
T24120STB-BS	6	24"	610	120"	3048	121	54.9
T24132STB-BS	8	24"	610	132"	3353	131	59.4
T24144STB-BS	8	24"	610	144"	3658	141	64.0
T3030STB-BS	4	30"	762	30"	762	51	23.1
T3036STB-BS	4	30"	762	36"	914	56	25.4
T3048STB-BS	4	30"	762	48"	1219	66	29.9
T3060STB-BS	4	30"	762	60"	1524	76	34.5
T3072STB-BS	4	30"	762	72"	1829	86	39.0
T3084STB-BS	4	30"	762	84"	2134	96	43.6
T3096STB-BS	6	30"	762	96"	2438	106	48.1
T30108STB-BS	6	30"	762	108"	2743	116	52.6
T30120STB-BS	6	30"	762	120"	3048	126	57.2
T30132STB-BS	8	30"	762	132"	3353	136	61.7
T30144STB-BS	8	30"	762	144"	3658	146	66.2
T3648STB-BS	4	36"	914	48"	1219	71	32.2
T3660STB-BS	4	36"	914	60"	1524	81	36.7
T3672STB-BS	4	36"	914	72"	1829	91	41.3
T3684STB-BS	4	36"	914	84"	2134	101	45.8
T3696STB-BS	6	36"	914	96"	2438	111	50.3
T36108STB-BS	6	36"	914	108"	2743	121	54.9
T36120STB-BS	6	36"	914	120"	3048	131	59.4
T36132STB-BS	8	36"	914	132"	3353	141	64.0
T36144STB-BS	8	36"	914	144"	3658	151	68.5

**NEW Option for Worktables with Stainless Steel Base: Knockdown Welded Base**

**PATENT PENDING**



worktable shown with base knocked down



worktable assembled

- Precision machined stainless steel threaded inserts pressed into 16 gauge 1 5/8"-diameter leg sections for knockdown construction
- C-Frame stainless steel tubular base

Add suffix **"-KDWB"** to worktable model number (ex: T2436STB-BS-KDWB). See EG8217 for more info.



### Short Form Specifications

Top constructed of 16 gauge 300 series stainless steel with 1½" roll on front, 4½" backslash, and sides turned down 90°. Open front with 1¼" O.D., stainless steel tubular crossbracing on sides and rear. Top reinforced with welded hat channels and sound deadened. Constructed with uni-lok® patented gusset system with the gussets recessed into the hat channels to reduce lateral movement. Legs are 1½" O.D., stainless steel tubing, with stainless steel gussets and 1" stainless steel adjustable bullet feet.



*worktable with backslash  
and tubular base  
—shown with optional drawer*

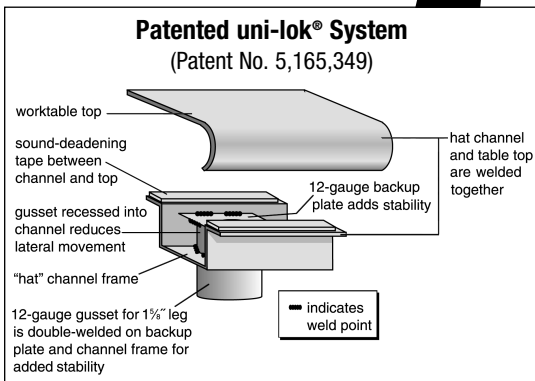

### MODELS:

- |                                       |  |  |  |
|---------------------------------------|--|--|--|
| <input type="checkbox"/> T2424STEB-BS | <input type="checkbox"/> T24108STEB-BS | <input type="checkbox"/> T3072STEB-BS  | <input type="checkbox"/> T3660STEB-BS  |
| <input type="checkbox"/> T2430STEB-BS | <input type="checkbox"/> T24120STEB-BS | <input type="checkbox"/> T3084STEB-BS  | <input type="checkbox"/> T3672STEB-BS  |
| <input type="checkbox"/> T2436STEB-BS | <input type="checkbox"/> T24132STEB-BS | <input type="checkbox"/> T3096STEB-BS  | <input type="checkbox"/> T3684STEB-BS  |
| <input type="checkbox"/> T2448STEB-BS | <input type="checkbox"/> T24144STEB-BS | <input type="checkbox"/> T30108STEB-BS | <input type="checkbox"/> T3696STEB-BS  |
| <input type="checkbox"/> T2460STEB-BS | <input type="checkbox"/> T3030STEB-BS  | <input type="checkbox"/> T30120STEB-BS | <input type="checkbox"/> T36108STEB-BS |
| <input type="checkbox"/> T2472STEB-BS | <input type="checkbox"/> T3036STEB-BS  | <input type="checkbox"/> T30132STEB-BS | <input type="checkbox"/> T36120STEB-BS |
| <input type="checkbox"/> T2484STEB-BS | <input type="checkbox"/> T3048STEB-BS  | <input type="checkbox"/> T30144STEB-BS | <input type="checkbox"/> T36132STEB-BS |
| <input type="checkbox"/> T2496STEB-BS | <input type="checkbox"/> T3060STEB-BS  | <input type="checkbox"/> T3648STEB-BS  | <input type="checkbox"/> T36144STEB-BS |

### Tabletop

- Patented uni-lok® gusset system (patent #5,165,349): gussets are recessed into hat channel, reducing lateral movement.
- Top reinforced with welded-on hat channel.
- Sound-deadened between top and channels.
- 4½" (114mm)-high 90° backslash with 1" (25mm) turn at 90°.
- 1½" (38mm)-diameter 180° rolled edge on front. Ends are turned down 90°, providing for flush installations when required.
- 16 gauge 300 series polished stainless steel.

### Crossbracing—1¼" (38mm)-diameter

- Heavy gauge stainless steel.
- Aluminum castings join crossbraces, legs and rear brace.

### Legs—1½" (41mm)-diameter

- Tables 96" (2438mm) and longer come with six legs or more.
- Heavy gauge stainless steel.
- 1" (25mm) adjustable stainless steel feet.

### Options / Accessories

- |   |   |
|---|---|
| <input type="checkbox"/> Drawer                                   | <input type="checkbox"/> Duplex receptacles                               |
| <input type="checkbox"/> Lock                                     | <input type="checkbox"/> Overshelves                                      |
| <input type="checkbox"/> Casters                                  | <input type="checkbox"/> Pot rack   |
| <input type="checkbox"/> Power strip (for material handling)      | <input type="checkbox"/> Sink   |
| <input type="checkbox"/> Knockdown Welded Base<br>(see back page) | <input type="checkbox"/> Stabilizer Bar (for 30"-<br>and 36"-wide tables) |



\*\*For custom sizes - fill in required dimensions in layout provided

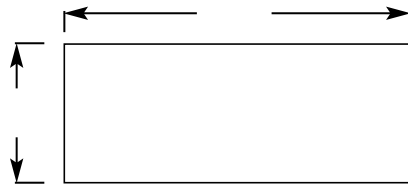

TOP VIEW

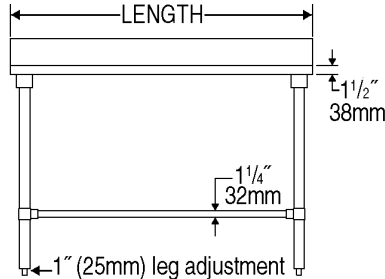

FRONT VIEW

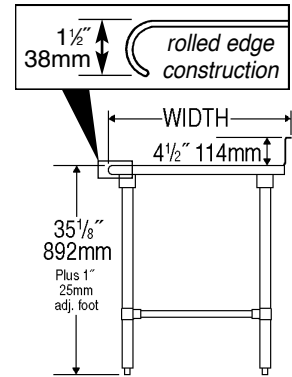

SIDE VIEW

model #	# of legs	width		length		weight	
		in.	mm	in.	mm	lbs.	kg
T2424STEB-BS	4	24"	610	24"	610	41	18.6
T2430STEB-BS	4	24"	610	30"	762	46	20.9
T2436STEB-BS	4	24"	610	36"	914	51	23.1
T2448STEB-BS	4	24"	610	48"	1219	61	27.7
T2460STEB-BS	4	24"	610	60"	1524	71	32.2
T2472STEB-BS	4	24"	610	72"	1829	81	36.7
T2484STEB-BS	4	24"	610	84"	2134	91	41.3
T2496STEB-BS	6	24"	610	96"	2438	101	45.8
T24108STEB-BS	6	24"	610	108"	2743	111	50.3
T24120STEB-BS	6	24"	610	120"	3048	121	54.9
T24132STEB-BS	8	24"	610	132"	3353	131	59.4
T24144STEB-BS	8	24"	610	144"	3658	141	64.0
T3030STEB-BS	4	30"	762	30"	762	51	23.1
T3036STEB-BS	4	30"	762	36"	914	56	25.4
T3048STEB-BS	4	30"	762	48"	1219	66	29.9
T3060STEB-BS	4	30"	762	60"	1524	76	34.5
T3072STEB-BS	4	30"	762	72"	1829	86	39.0
T3084STEB-BS	4	30"	762	84"	2134	96	43.6
T3096STEB-BS	6	30"	762	96"	2438	106	48.1
T30108STEB-BS	6	30"	762	108"	2743	116	52.6
T30120STEB-BS	6	30"	762	120"	3048	126	57.2
T30132STEB-BS	8	30"	762	132"	3353	136	61.7
T30144STEB-BS	8	30"	762	144"	3658	146	66.2
T3648STEB-BS	4	36"	914	48"	1219	71	32.2
T3660STEB-BS	4	36"	914	60"	1524	81	36.7
T3672STEB-BS	4	36"	914	72"	1829	91	41.3
T3684STEB-BS	4	36"	914	84"	2134	101	45.8
T3696STEB-BS	6	36"	914	96"	2438	111	50.3
T36108STEB-BS	6	36"	914	108"	2743	121	54.9
T36120STEB-BS	6	36"	914	120"	3048	131	59.4
T36132STEB-BS	8	36"	914	132"	3353	141	64.0
T36144STEB-BS	8	36"	914	144"	3658	151	68.5

**NEW Option for Worktables with Stainless Steel Base: Knockdown Welded Base**

**PATENT PENDING**



worktable shown with base knocked down



worktable assembled

- Precision machined stainless steel threaded inserts pressed into 16 gauge 1 5/8"-diameter leg sections for knockdown construction
- C-Frame stainless steel tubular base

Add suffix **"-KDWB"** to worktable model number (ex: T2436STEB-BS-KDWB). See EG8217 for more info.



## Short Form Specifications

Top to be constructed of 14/304 stainless steel with 1½" roll on front, 4½" backplash, and sides turned down 90°. Open front with 1¼" O.D., stainless steel tubular cross bracing on sides and rear. Top reinforced with welded hat channels and sound deadened. Constructed with uni-lok® patented gusset system with the gussets recessed into the hat channels to reduce lateral movement. Legs to be 1½" O.D., stainless steel tubing, with stainless steel gussets and 1" adjustable stainless steel bullet feet.



*worktable with backplash  
and tubular base  
—shown with optional drawer*

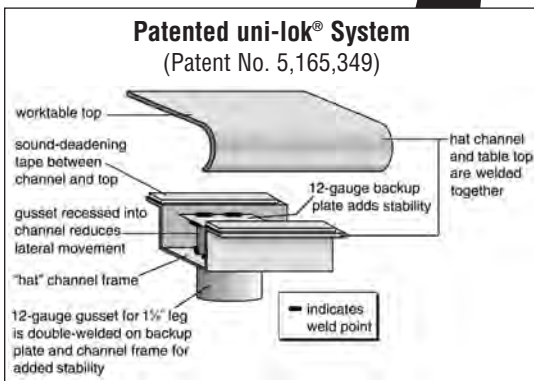

## MODELS:

<input type="checkbox"/> T2424STE-BS	<input type="checkbox"/> T24108STE-BS	<input type="checkbox"/> T3072STE-BS	<input type="checkbox"/> T3660STE-BS
<input type="checkbox"/> T2430STE-BS	<input type="checkbox"/> T24120STE-BS	<input type="checkbox"/> T3084STE-BS	<input type="checkbox"/> T3672STE-BS
<input type="checkbox"/> T2436STE-BS	<input type="checkbox"/> T24132STE-BS	<input type="checkbox"/> T3096STE-BS	<input type="checkbox"/> T3684STE-BS
<input type="checkbox"/> T2448STE-BS	<input type="checkbox"/> T24144STE-BS	<input type="checkbox"/> T30108STE-BS	<input type="checkbox"/> T3696STE-BS
<input type="checkbox"/> T2460STE-BS	<input type="checkbox"/> T3030STE-BS	<input type="checkbox"/> T30120STE-BS	<input type="checkbox"/> T36108STE-BS
<input type="checkbox"/> T2472STE-BS	<input type="checkbox"/> T3036STE-BS	<input type="checkbox"/> T30132STE-BS	<input type="checkbox"/> T36120STE-BS
<input type="checkbox"/> T2484STE-BS	<input type="checkbox"/> T3048STE-BS	<input type="checkbox"/> T30144STE-BS	<input type="checkbox"/> T36132STE-BS
<input type="checkbox"/> T2496STE-BS	<input type="checkbox"/> T3060STE-BS	<input type="checkbox"/> T3648STE-BS	<input type="checkbox"/> T36144STE-BS

## Tabletop

- Patented uni-lok® gusset system (patent #5,165,349): gussets are recessed into hat channel, reducing lateral movement.
- Top reinforced with welded-on hat channel.
- Sound-deadened between top and channels.
- 4½" (114mm)-high 90° backplash with 1" (25mm) turn at 90°.
- 1½" (38mm)-diameter 180° rolled edge on front. Ends are turned down 90°, providing for flush installations when required.
- 14 gauge type 304 polished stainless steel.

## Crossbracing—1¼" (38mm)-diameter

- Heavy gauge stainless steel.
- Aluminum castings join crossbraces, legs and rear brace.

## Legs—1½" (41mm)-diameter

- Tables 96" (2438mm) and longer come with six legs or more.
- Heavy gauge stainless steel.
- 1" (25mm) adjustable stainless steel feet.

## Options / Accessories

- |  |   |
|--|---|
| <input type="checkbox"/> Drawer                              | <input type="checkbox"/> Duplex receptacles                               |
| <input type="checkbox"/> Lock                                | <input type="checkbox"/> Pot rack   |
| <input type="checkbox"/> Casters                             | <input type="checkbox"/> Sink   |
| <input type="checkbox"/> Stainless steel bullet feet         | <input type="checkbox"/> Stabilizer Bar (for 30"-<br>and 36"-wide tables) |
| <input type="checkbox"/> Overshelves                         |   |
| <input type="checkbox"/> Power strip (for material handling) |   |



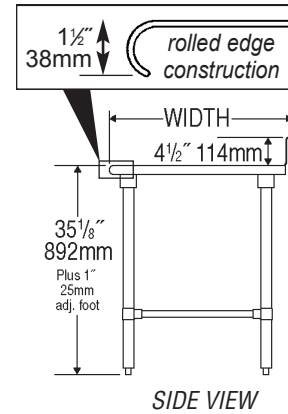
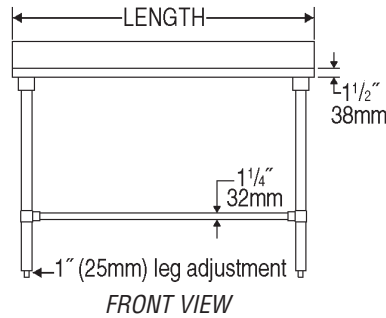
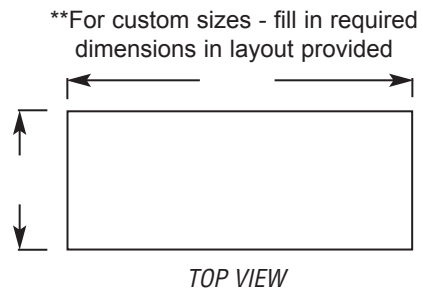

model #	# of legs	width		length		weight	
		in.	mm	in.	mm	lbs.	kg
T2424STE-BS	4	24"	610	24"	610	45	20.4
T2430STE-BS	4	24"	610	30"	762	51	23.1
T2436STE-BS	4	24"	610	36"	914	56	25.4
T2448STE-BS	4	24"	610	48"	1219	67	30.4
T2460STE-BS	4	24"	610	60"	1524	78	35.4
T2472STE-BS	4	24"	610	72"	1829	89	40.4
T2484STE-BS	4	24"	610	84"	2134	100	45.4
T2496STE-BS	6	24"	610	96"	2438	111	50.3
T24108STE-BS	6	24"	610	108"	2743	122	55.8
T24120STE-BS	6	24"	610	120"	3048	133	60.3
T24132STE-BS	8	24"	610	132"	3353	144	65.3
T24144STE-BS	8	24"	610	144"	3658	155	70.3
T3030STE-BS	4	30"	762	30"	762	56	25.4
T3036STE-BS	4	30"	762	36"	914	62	28.1
T3048STE-BS	4	30"	762	48"	1219	73	33.1
T3060STE-BS	4	30"	762	60"	1524	84	38.1
T3072STE-BS	4	30"	762	72"	1829	95	43.1
T3084STE-BS	4	30"	762	84"	2134	106	48.1
T3096STE-BS	6	30"	762	96"	2438	117	53.1
T30108STE-BS	6	30"	762	108"	2743	128	58.1
T30120STE-BS	6	30"	762	120"	3048	139	63.1
T30132STE-BS	8	30"	762	132"	3353	150	68.0
T30144STE-BS	8	30"	762	144"	3658	161	73.0
T3648STE-BS	4	36"	914	48"	1219	78	35.4
T3660STE-BS	4	36"	914	60"	1524	89	40.4
T3672STE-BS	4	36"	914	72"	1829	100	45.4
T3684STE-BS	4	36"	914	84"	2134	111	50.3
T3696STE-BS	6	36"	914	96"	2438	122	55.3
T36108STE-BS	6	36"	914	108"	2743	133	60.3
T36120STE-BS	6	36"	914	120"	3048	144	65.3
T36132STE-BS	8	36"	914	132"	3353	155	70.3
T36144STE-BS	8	36"	914	144"	3658	166	75.3





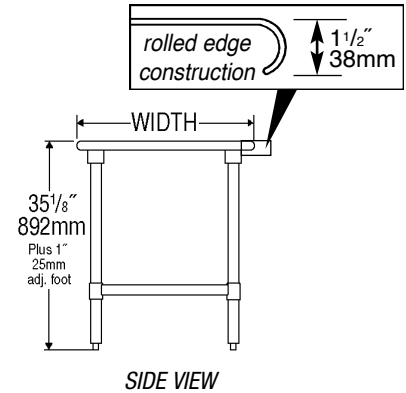
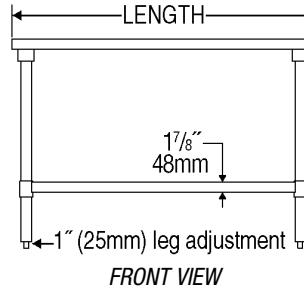
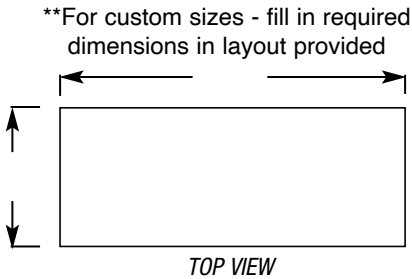

model #	# of legs	width		length		weight	
		in.	mm	in.	mm	lbs.	kg
T2424SB	4	24"	610	24"	610	42	19.0
T2430SB	4	24"	610	30"	762	45	20.4
T2436SB	4	24"	610	36"	914	50	22.7
T2448SB	4	24"	610	48"	1219	61	27.7
T2460SB	4	24"	610	60"	1524	71	32.2
T2472SB	4	24"	610	72"	1829	82	37.2
T2484SB	4	24"	610	84"	2134	94	42.6
T2496SB	6	24"	610	96"	2438	114	51.7
T24108SB	6	24"	610	108"	2743	131	59.4
T24120SB	6	24"	610	120"	3048	148	67.1
T24132SB	8	24"	610	132"	3353	165	74.8
T24144SB	8	24"	610	144"	3658	182	82.6
T3030SB	4	30"	762	30"	762	49	22.0
T3036SB	4	30"	762	36"	914	52	23.6
T3048SB	4	30"	762	48"	1219	68	30.1
T3060SB	4	30"	762	60"	1524	79	35.8
T3072SB	4	30"	762	72"	1829	92	41.7
T3084SB	4	30"	762	84"	2134	105	47.6
T3096SB	6	30"	762	96"	2438	126	57.2
T30108SB	6	30"	762	108"	2743	146	66.2
T30120SB	6	30"	762	120"	3048	165	74.8
T30132SB	8	30"	762	132"	3353	185	84.0
T30144SB	8	30"	762	144"	3658	204	92.5
T3648SB	4	36"	914	48"	1219	75	34.0
T3660SB	4	36"	914	60"	1524	88	40.0
T3672SB	4	36"	914	72"	1829	104	47.2
T3684SB	4	36"	914	84"	2134	120	54.4
T3696SB	6	36"	914	96"	2438	139	63.1
T36108SB	6	36"	914	108"	2743	164	74.4
T36120SB	6	36"	914	120"	3048	188	85.3
T36132SB	8	36"	914	132"	3353	213	96.6
T36144SB	8	36"	914	144"	3658	237	107.5

**NEW Option for Worktables with Stainless Steel Base: Knockdown Welded Base**

**PATENT PENDING**

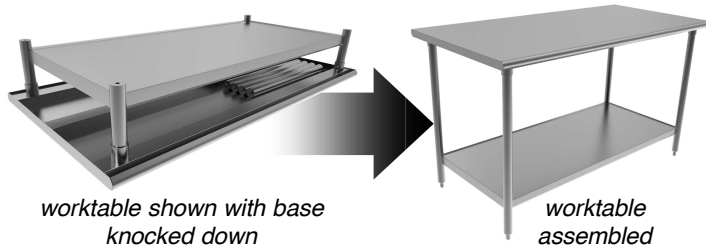

- Precision machined stainless steel threaded inserts pressed into 16 gauge 1 1/8"-diameter leg sections for knockdown construction
- Marine edge stainless steel undershelf welded to lower leg sections

Add suffix **"-KDWB"** to worktable model number (ex: T2436SB-KDWB). See EG8217 for more info.

