

# Electric Pallet Lift Table Technical Drawings

## SMS-09-V46-EHU-2

Deck tolerances +/- 1/2" Table  
height tolerances +/- 1/2"

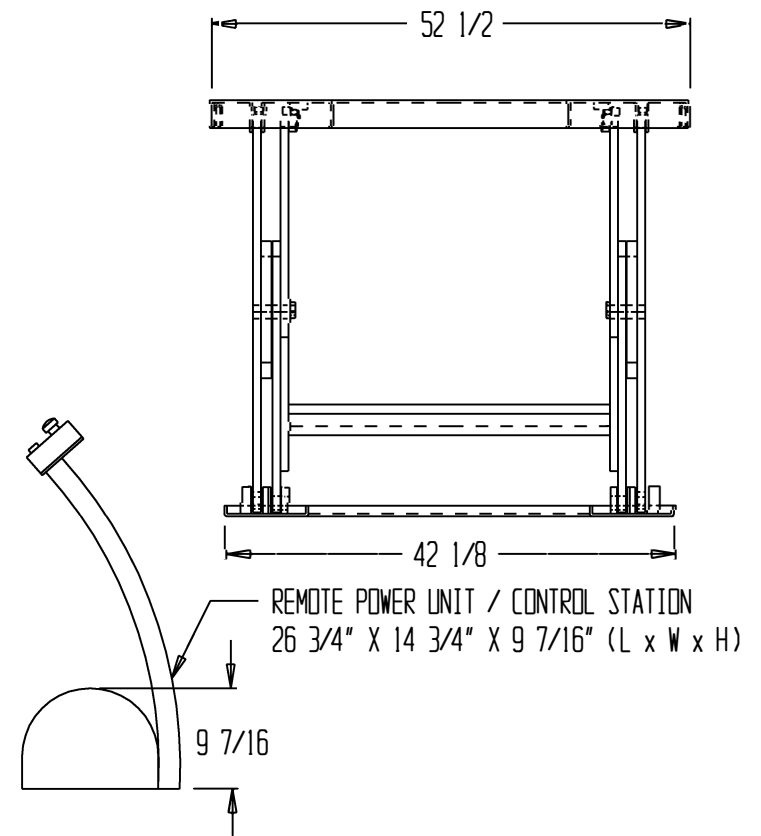
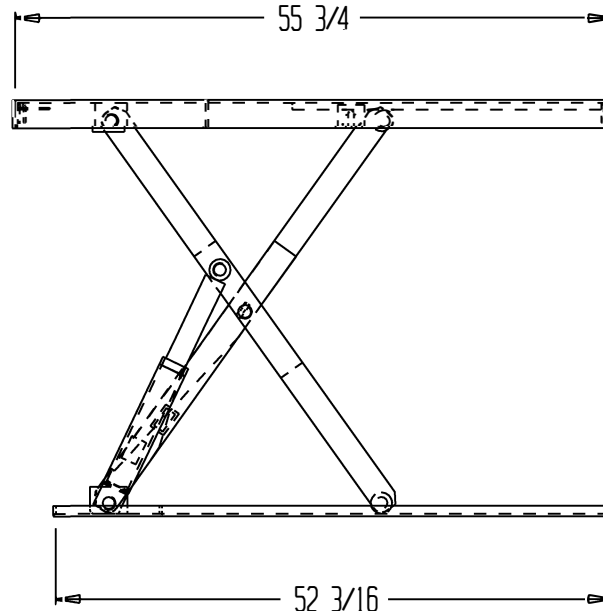

### STANDARD FEATURES

- STANDARD REMOTE POWER UNIT / CONTROL STATION
- RAISE TIME (LOADED) = 15 SECONDS
- LOWER TIME (LOADED) = 32 SECONDS
- 11.5 V AC SINGLE PHASE (ONLY)
- INCLUDES SAFETY MAINTENANCE PROPS
- WHEN PROPS ARE ENGAGED, OVERALL HEIGHT: 28"

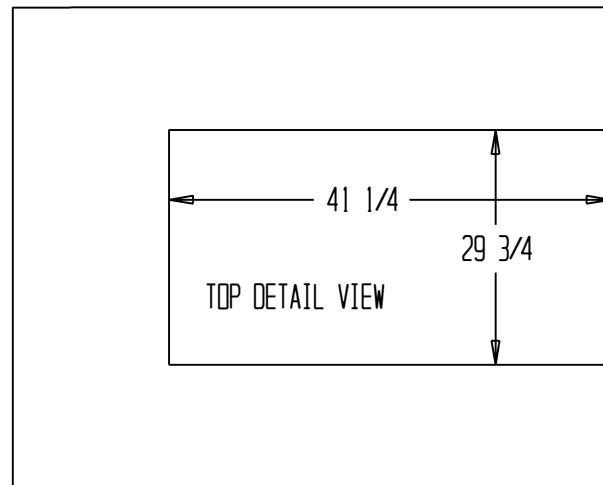

# SMS-09-V46-EHU-3

Deck tolerances +/- 1/2"  
Table height tolerances +/- 1/2"

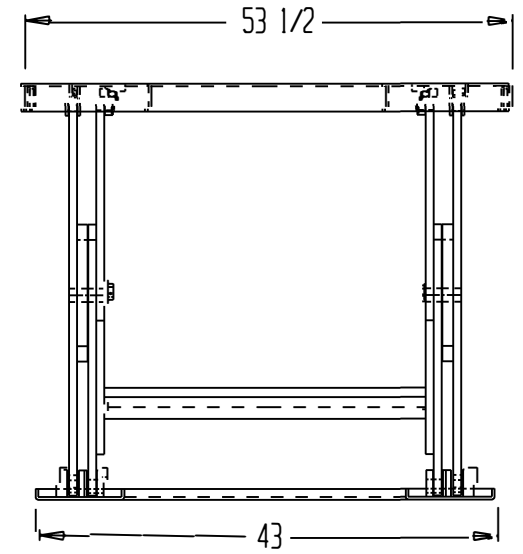
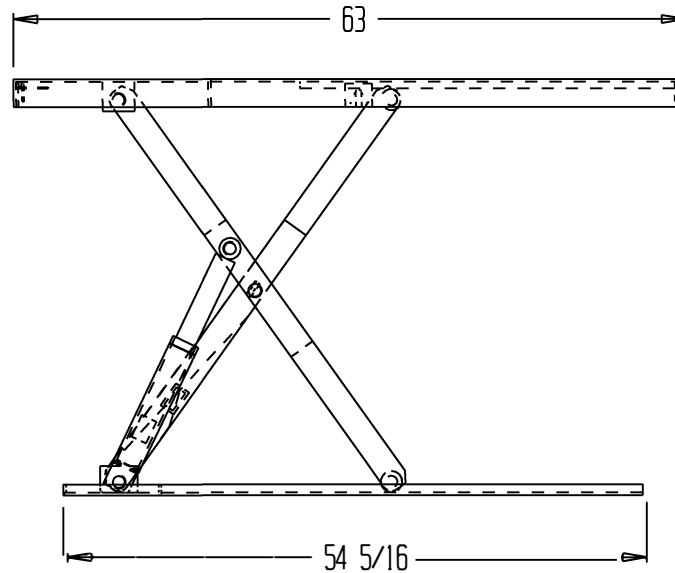

## STANDARD FEATURES

STANDARD REMOTE POWER UNIT / CONTROL STATION 11 5 V AC SINGLE PHASE (ONLY)  
INCLUDES SAFETY MAINTENANCE PROPS  
WHEN PROPS ARE ENGAGED, OVERALL HEIGHT: 28"

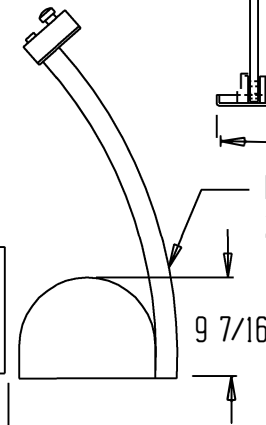
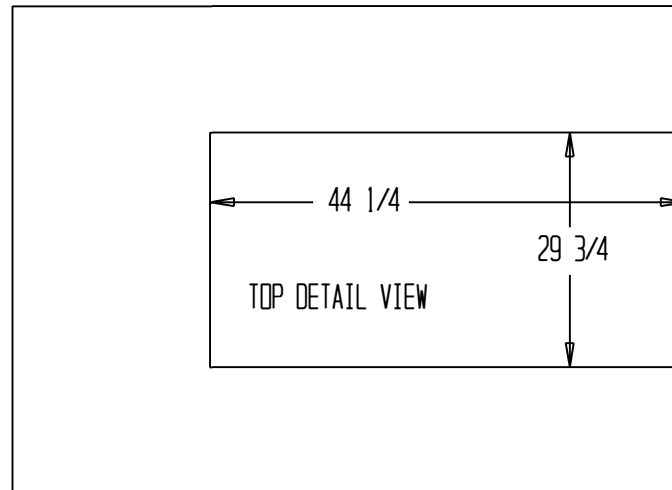

REMOTE POWER UNIT / CONTROL STATION  
26 3/4" X 14 3/4" X 9 7/16" (L x W x H)

