

Electric Floor Crane Technical Drawing

SMS-09-V46-EPFC-25

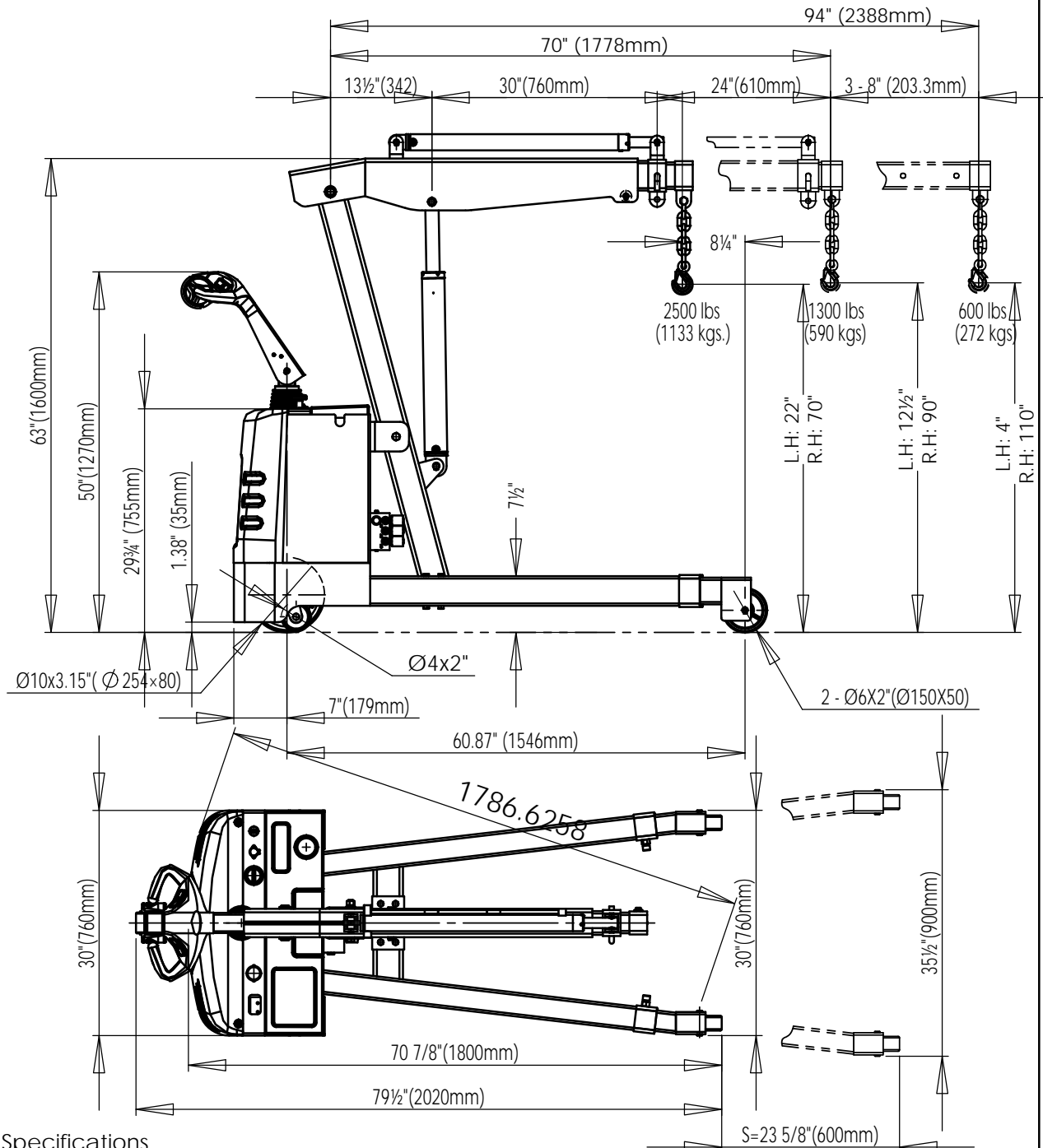

Specifications

- Maximum Capacity (boom fully retracted): 2,500 lbs (1133 kgs)
- Maximum Capacity (boom fully extended): 600 lbs (272 kgs)
- Drive Motor: DC24V/0.7KW
- Lift Motor: DC24V/2KW
- Battery: 2x12V/85-95Ah
- Battery Charger: 24V/12amp
- Lift Speed w/o Load: 0.70"/sec
- Lift Speed w/load: 1/2"/sec
- Lower down speed w/o load: 1/4"/sec
- Lower down speed w/load: 3/4"/sec
- Travel speed w/o load: 2.8 m/h
- Travel speed w/load: 2.18 m/h
- Gradeability: 0%

