

Sliding Box Shelving Storage Systems Assembly Guide

SMS-08-V25

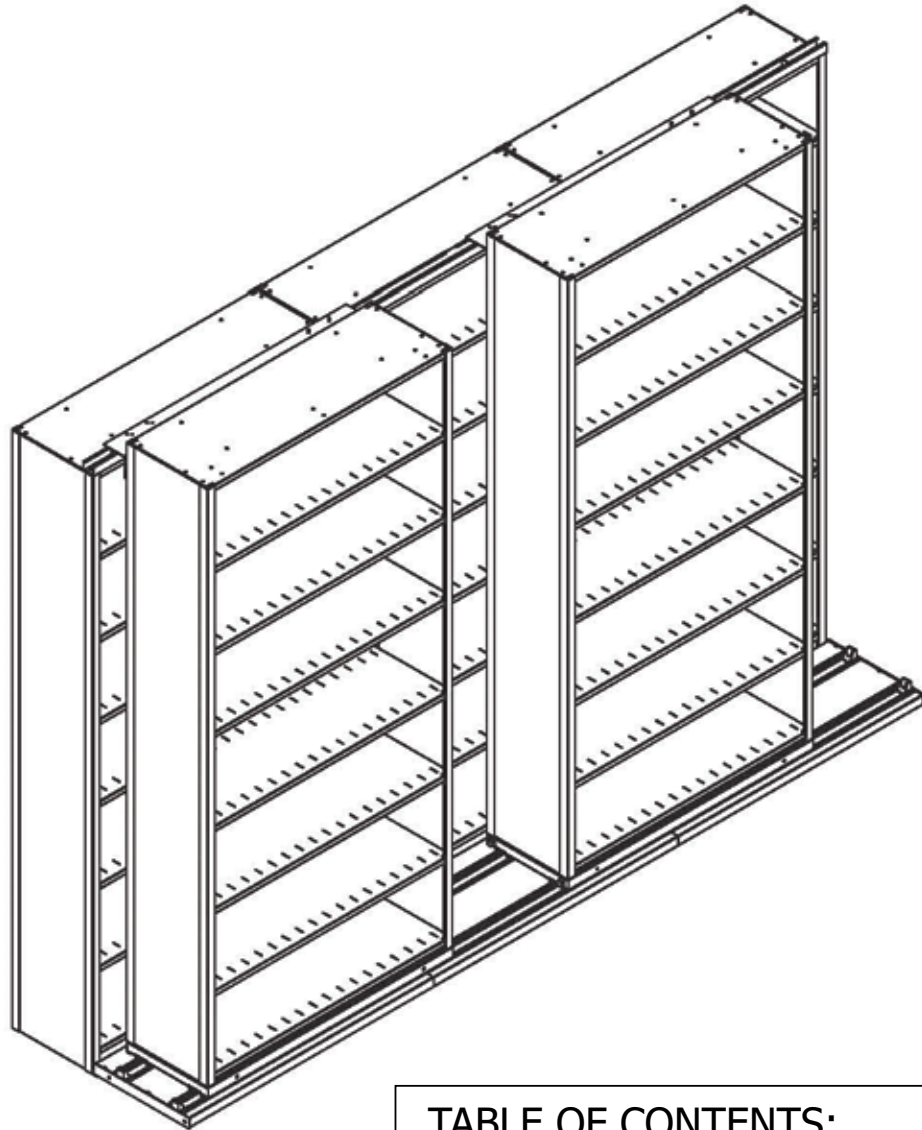
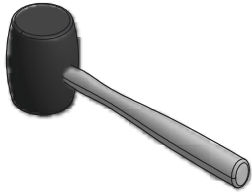


TABLE OF CONTENTS:

Table of Contents	1
Tools Required for Installation	2
Stationary Shelving Assembly	3-9
Mobile Shelving Assembly	10-28
Rail Assembly	11-15
BiSlider Unit Assembly	16-24
Tri/QuadSlider Unit Assembly	25-28
Final Assembly	29-31
Safety Precautions/Loading the System/ System Re-leveling.....	31

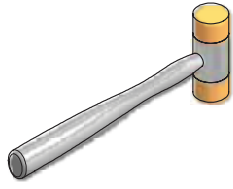


Tools Required for Assembly

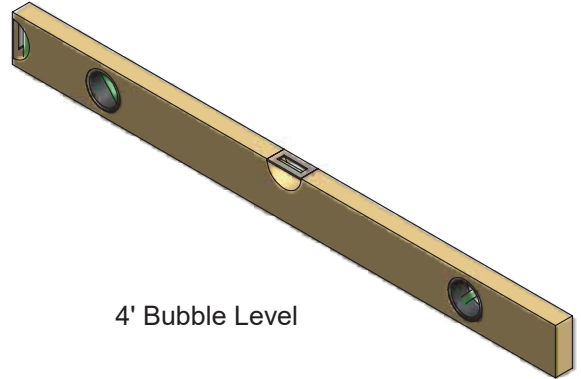


Rubber Mallet

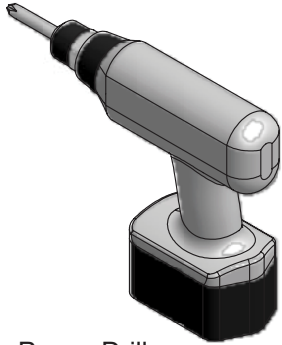
Or



Plastic Tip Hammer



4' Bubble Level



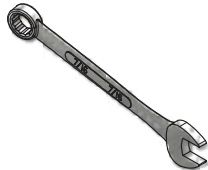
Power Drill



5/16" Drill Bit
(Required when not
using Datum shelving)



Phillips Head
Screwdriver



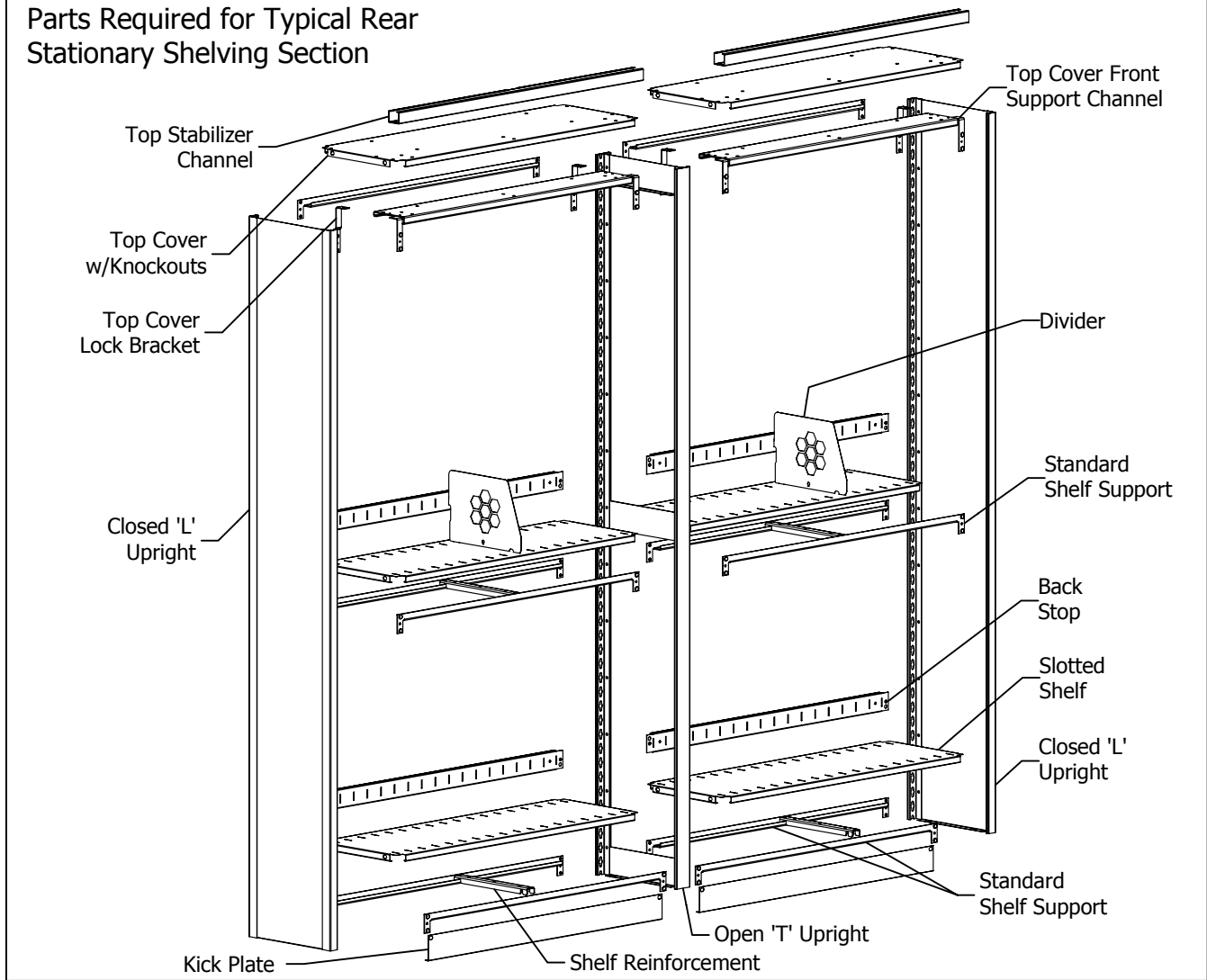
7/16" Wrench



7/32" Nut
Driver

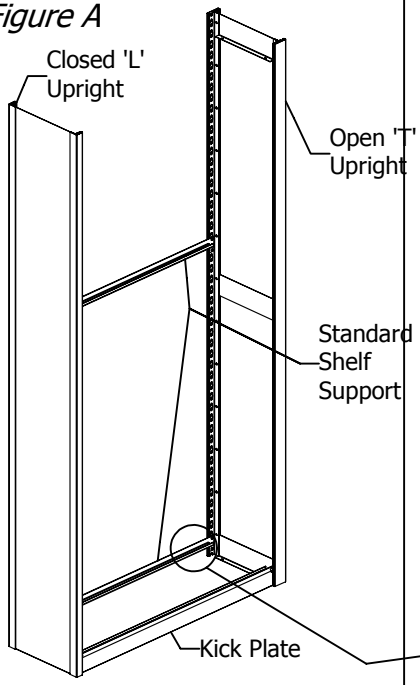


Parts Required for Typical Rear Stationary Shelving Section



NOTE: FREESTANDING UNITS MUST BE SECURED TO THE WALL, FLOOR, OR CEILING USING FASTENERS SUPPLIED BY THE INSTALLER. FASTENERS MUST BE APPROPRIATE FOR THE MATERIAL TO WHICH THE SHELVING IS FASTENED.

Figure A



Step 1:

Temporarily mount a standard shelf support at chest height between a closed "L" upright on left and an open "T" upright on right to hold uprights in position (see Figure A). Make sure that the uprights are positioned so that bent flanges are at the bottom of the unit as shown in Detail B. Rivets of shelf support fit into keyholes on uprights as shown in Figure A & Detail B. Use a rubber mallet or plastic tip hammer to tap shelf support into bottom of keyholes.

Step 2:

A kick plate will only be used on the forward facing side of a single entry unit or both sides of a double entry unit. Place kick plate against uprights then place standard shelf support into uprights and tap in place with a rubber mallet or plastic tip hammer to seat rivets into bottom of keyholes.

NOTE:

The rivet in the shelf support will not go through the hole in the Kick Plate. The Kick Plate will be held in place by friction when the shelf support is mounted to the upright.

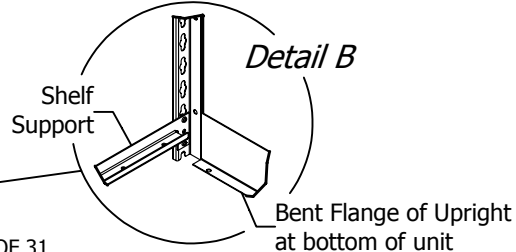
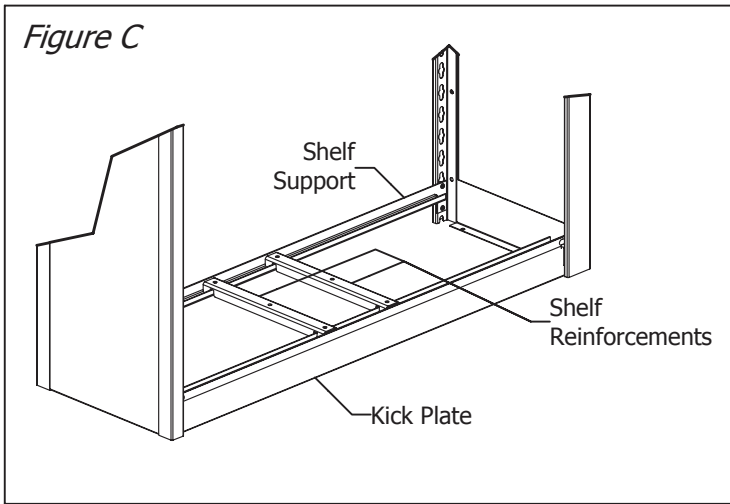


Figure C



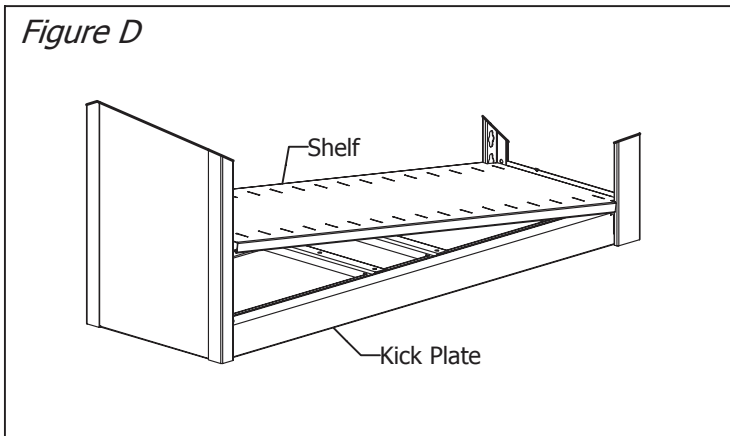
Step 3:

If required (See Table 1), install shelf reinforcements as shown in Figure C.

Table 1 - Shelf Reinforcements for Stationary Shelving

Depth of Shelving	Number of Reinforcements/Shelf
12"	None
15"	None
18"	Two

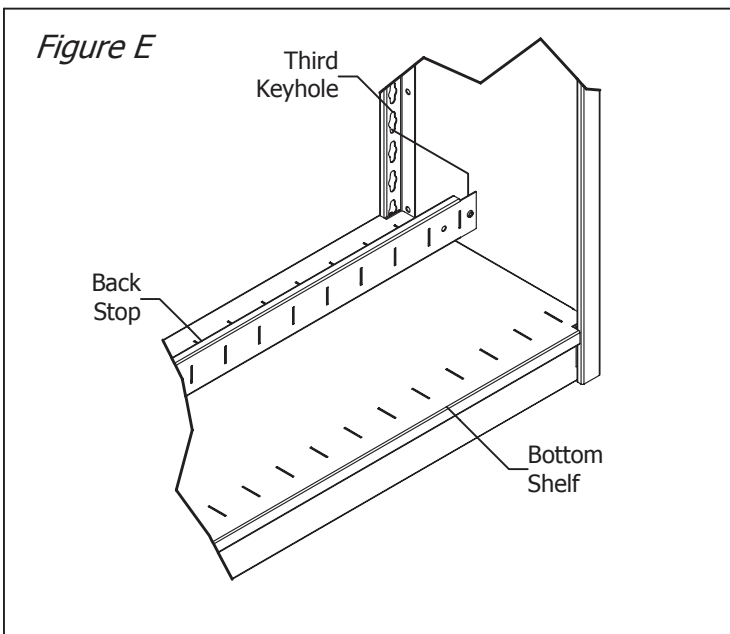
Figure D



Step 4:

Install bottom shelf by tilting the shelf as shown in Figure D. Shelf should then lie flat on shelf supports.

Figure E

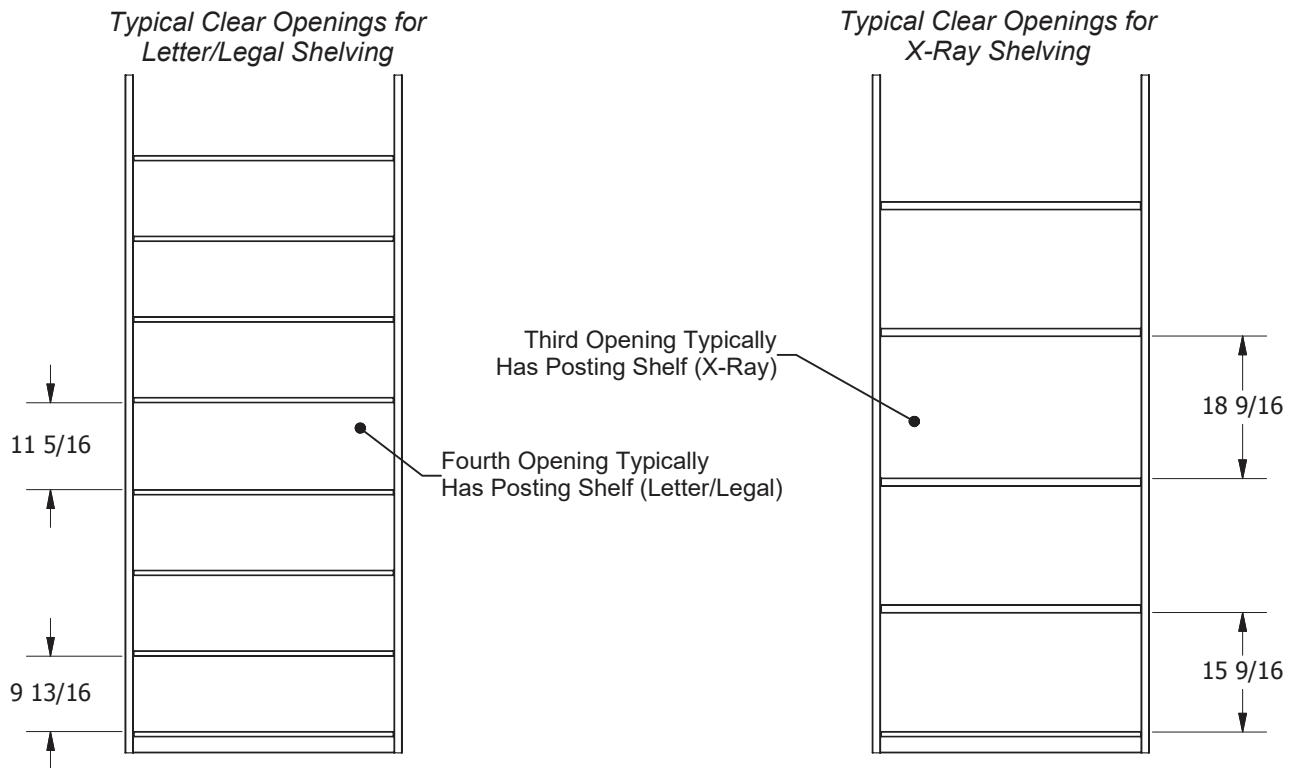


Step 5:

Install back stop for bottom shelf. Count up three complete keyholes from top of shelf and place rivets located on each end of back stop in these keyholes (see Figure E).

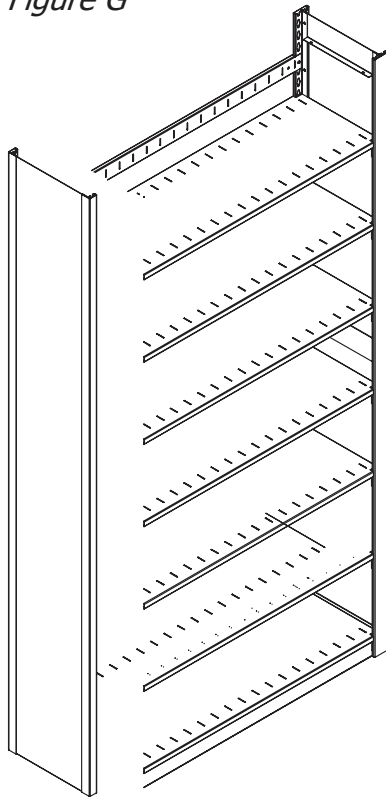


Figure F



If using or planning to use a posting shelf, leave space for it to be mounted when installing shelf supports and shelves. Not all shelving unit combinations will allow equal spacing of shelves when installing posting shelves. One opening will need to be larger than the rest. Check with your dealer or supplier for the correct choices of uprights and shelf openings required when a posting shelf is desired.

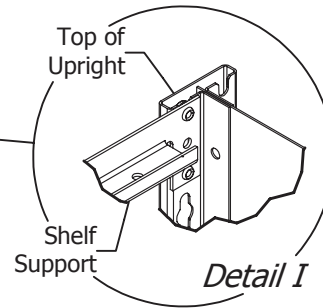
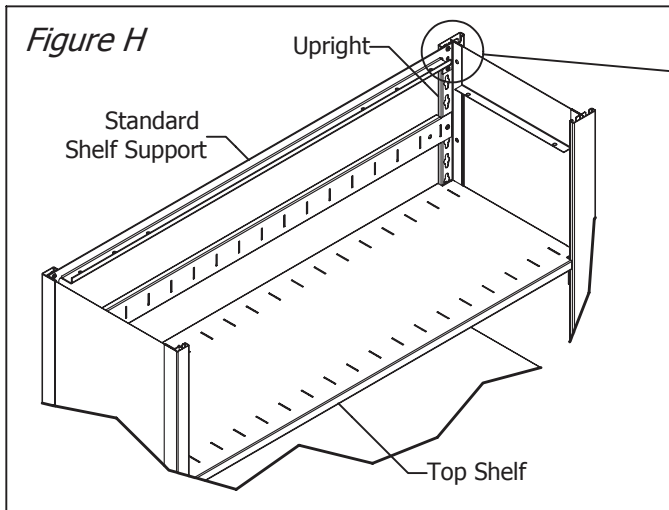
Figure G



Step 6:

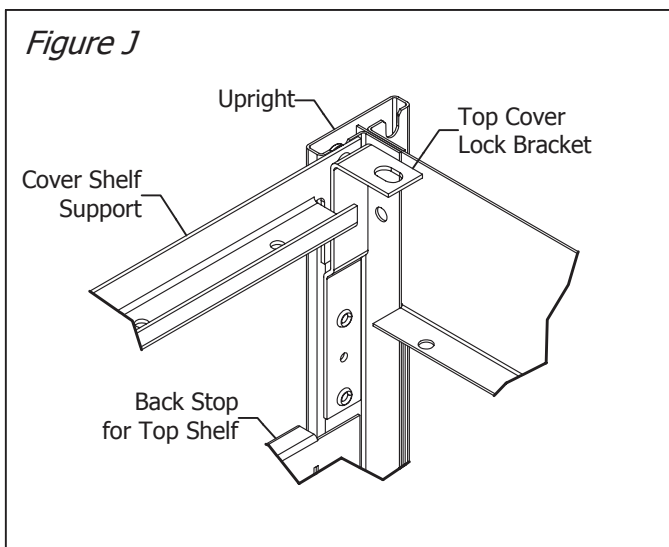
Install remainder of shelf supports, shelves, back stops, & shelf reinforcements (if required) as previously shown, working from bottom to top. Keep in mind your installation may be different, as shelf spacing varies from job to job (See Figure F for typical configurations). **Do not** install components at the top of unit at this time; when complete the assembled unit should look similar to Figure G.





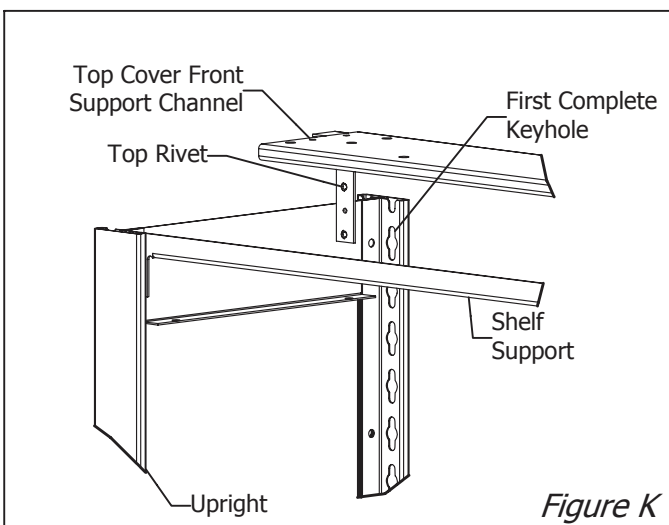
Step 7:

Install rear standard shelf support for top panel by placing rivets of support into the top two keyholes of the uprights as shown in Figure H and Detail I.



Step 8:

Install top cover lock brackets into both uprights as shown in Figure J by placing rivets of the brackets into first two keyholes under the shelf support.

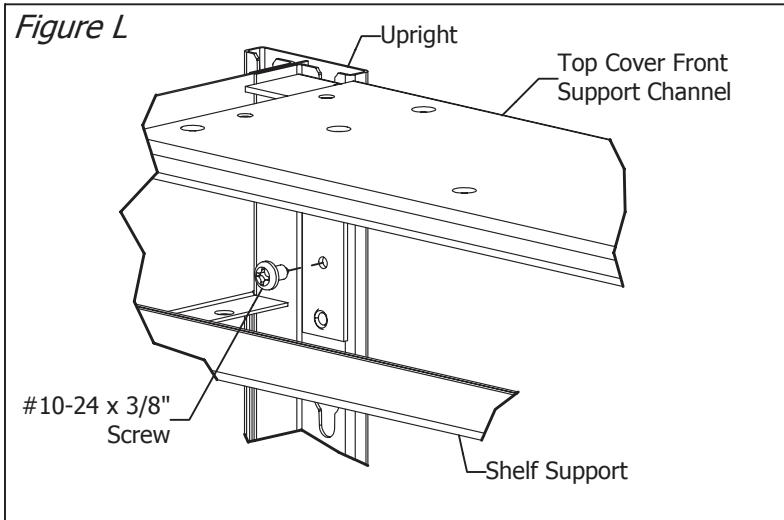


Step 9:

Install top cover front support channel by placing top rivet on each side of channel into the first complete keyhole in the top of both uprights as shown in Figure K.



Figure L



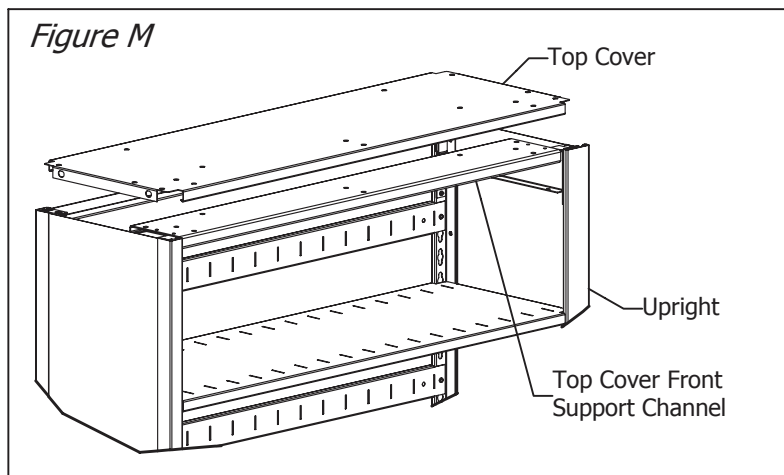
Step 10:

Secure top cover front support channel and both top cover lock brackets to uprights using #10-24 x 3/8" screws as shown in Figure L.

#10-24 x 3/8" Phillips Pan Head Sheet Metal Screw



Figure M



Step 11:

Place top cover on unit as shown in Figure M. Unit should now look similar to Figure N.

Figure N

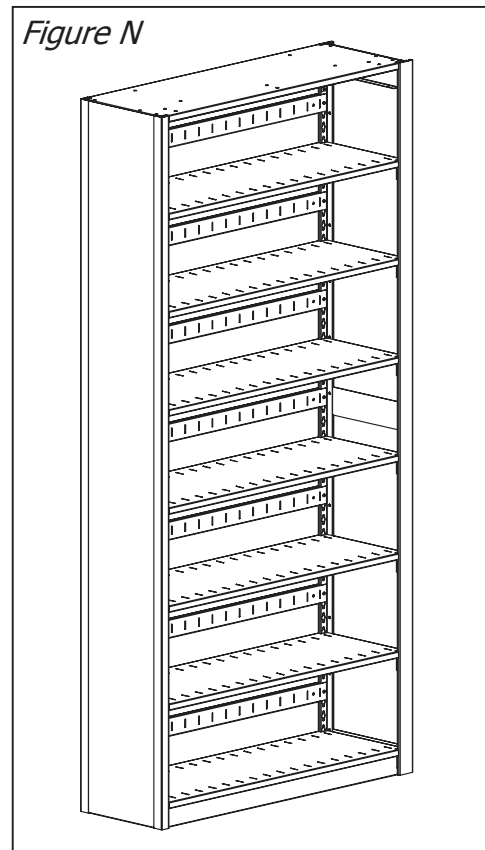
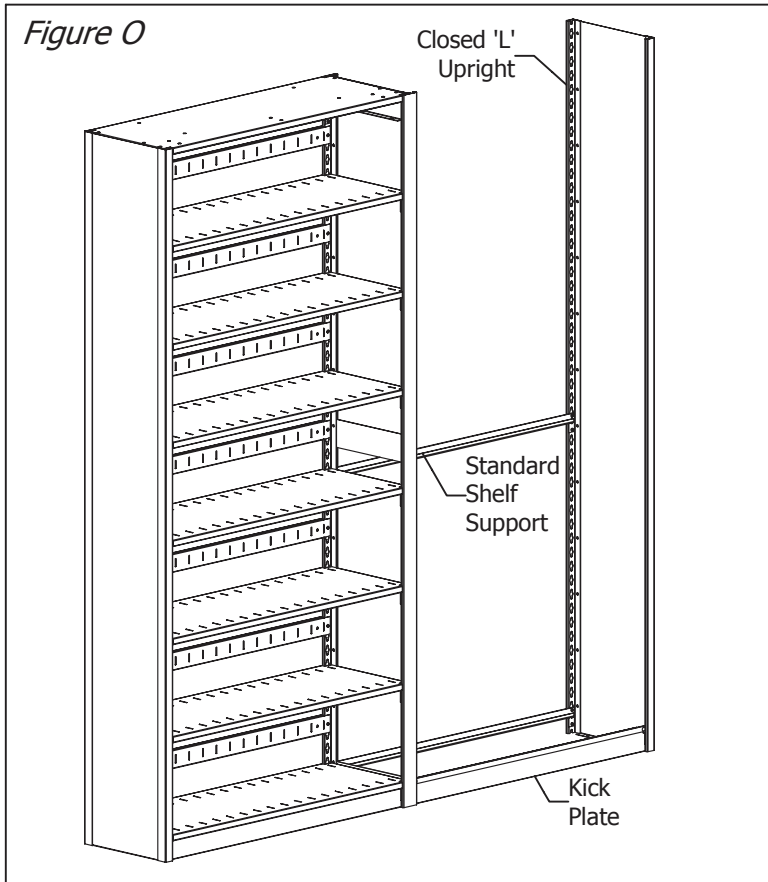


Figure O



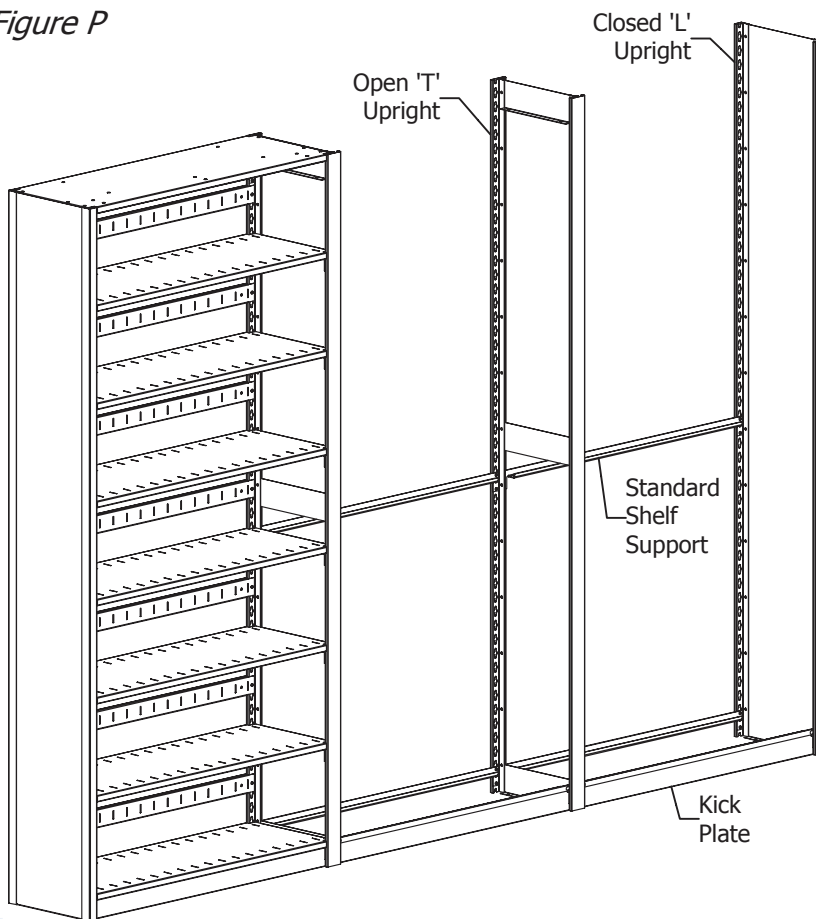
Note:

If the stationary shelving section consists of three or more units (Figure P), skip to Step 12b. If your section consists of two units only (Figure O), continue here with Step 12a.

Step 12a:

Position a closed 'L' upright to the right of assembled unit and install shelf supports and kick plate by repeating Steps 1 & 2 (Figure O). Go to Step 13.

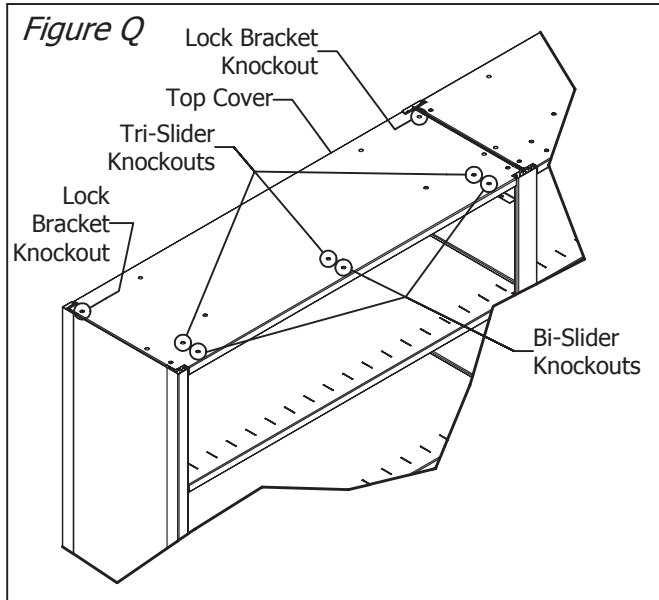
Figure P



Step 12b:

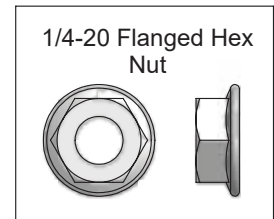
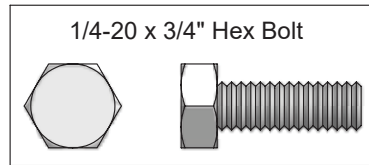
Repeat steps one and two as needed to set up all units in the section except for the end unit. For the end unit substitute a closed 'L' upright for an open 'T' upright (Figure P).





Step 13:

Remove bi-slider (all systems), tri-slider (tri-slide and quad-slide systems only) and lock bracket knockouts on top cover of first unit (see Figure Q). Remove knockouts with phillips screwdriver and rubber mallet or plastic tip hammer.



Step 14:

Use (3) 1/4-20 x 3/4 hex bolts and (3) 1/4-20 flanged hex nuts to attach top stabilizer channel to top cover of first unit using the first set of holes in the top cover. Use (1) 1/4-20 x 3/4 hex bolt & (1) 1/4-20 flanged hex nut to secure each top cover lock bracket (see Figure R).

Step 14a:

Repeat steps 13 & 14 for all units **except the end unit** which will not have a stabilizer channel attached during this part of assembly (See Figure S).

Step 14b:

For Tri/QuadSlider Systems Only, add a second top stabilizer channel behind channels that were attached in Steps 14 and 14a (See Figure T).

Step 14c:

For QuadSlider Systems Only, add a third top stabilizer channel behind channels that were attached in Steps 14, 14a and 14b. You will need to drill holes to mount this set of channels, maintain similar front to back spacing as for Bi/TriSlider stabilizer channels.

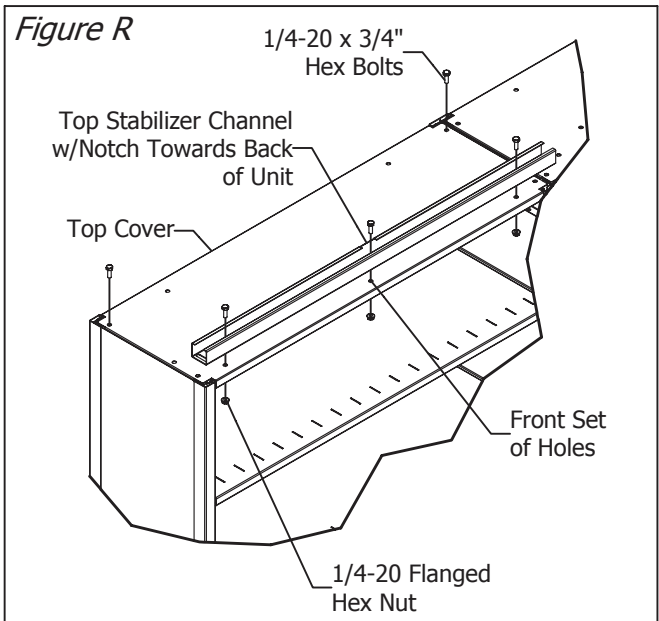


Figure T

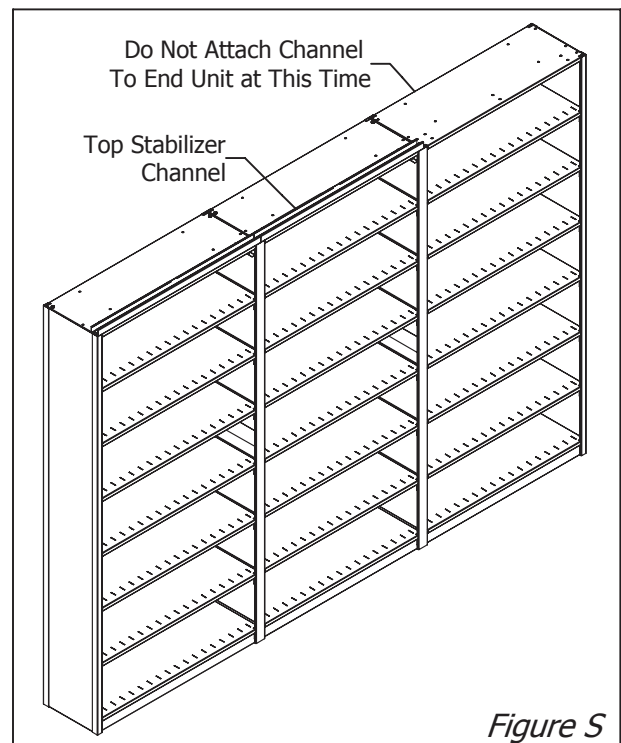
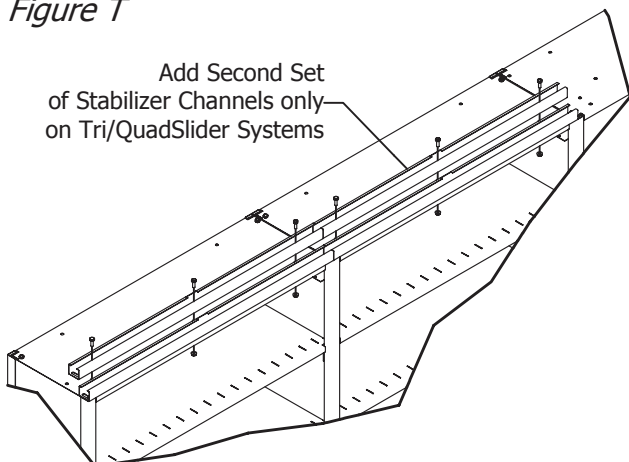


Figure S



Parts Required for Typical Moveable Shelving Section

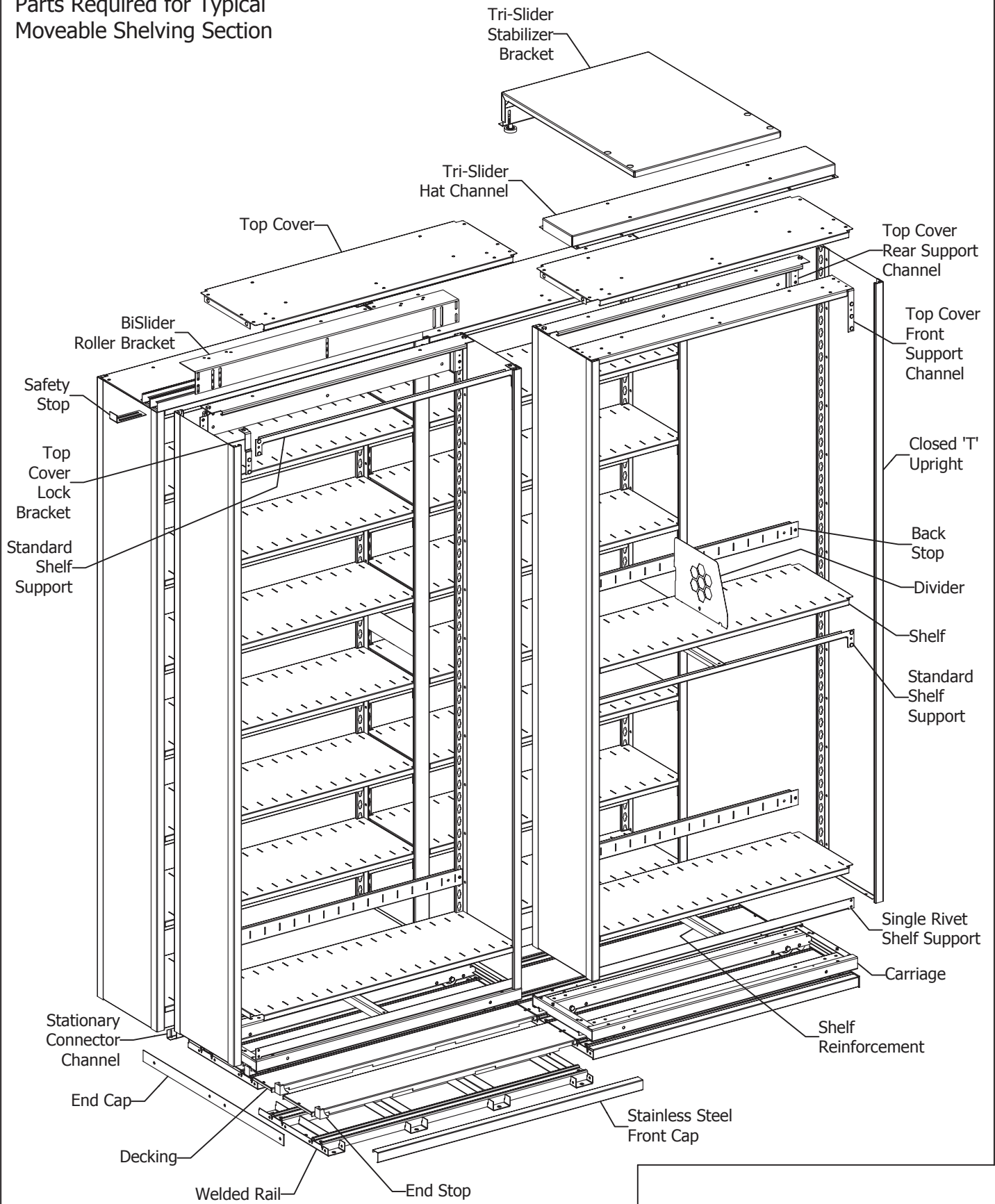
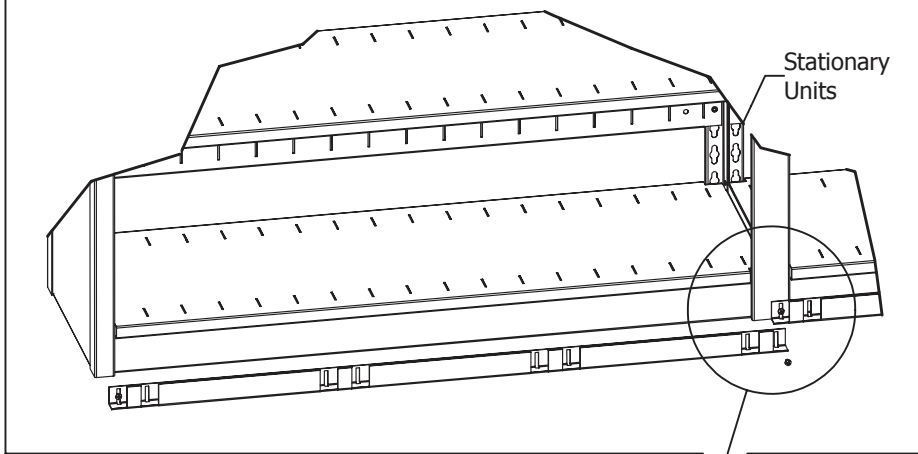


Figure U



Step 15:

Position a stationary connector channel in front of each stationary base unit. Attach each channel to the uprights of the stationary units using #8 tek screws as shown in Figure U and Detail V.

#8 x 3/8" Tek Screw



Detail V

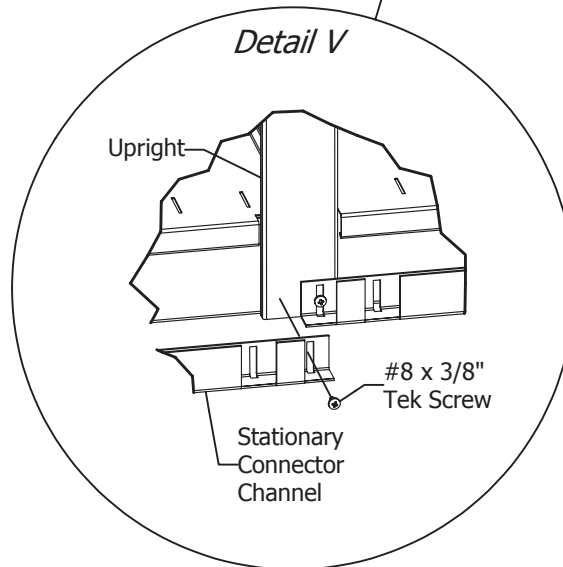
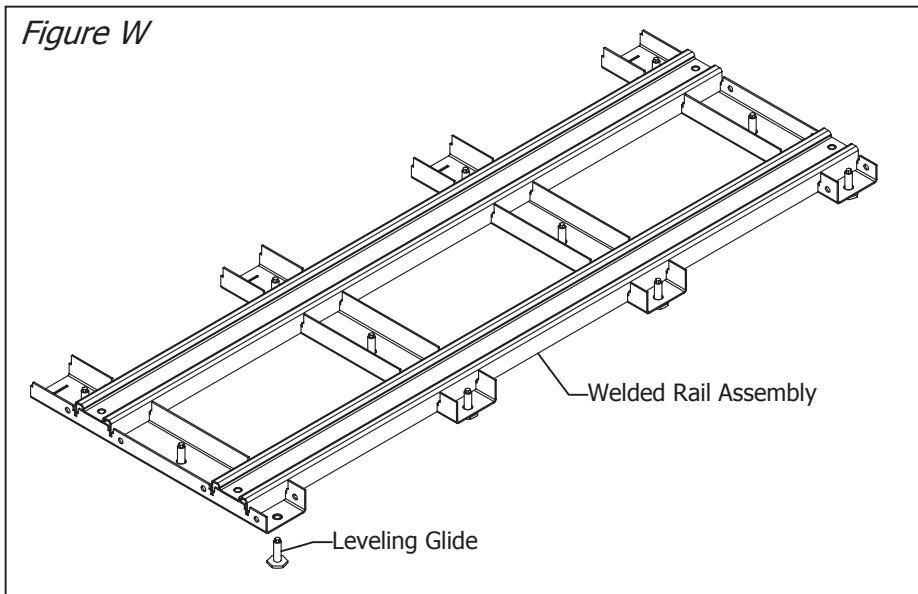


Figure W

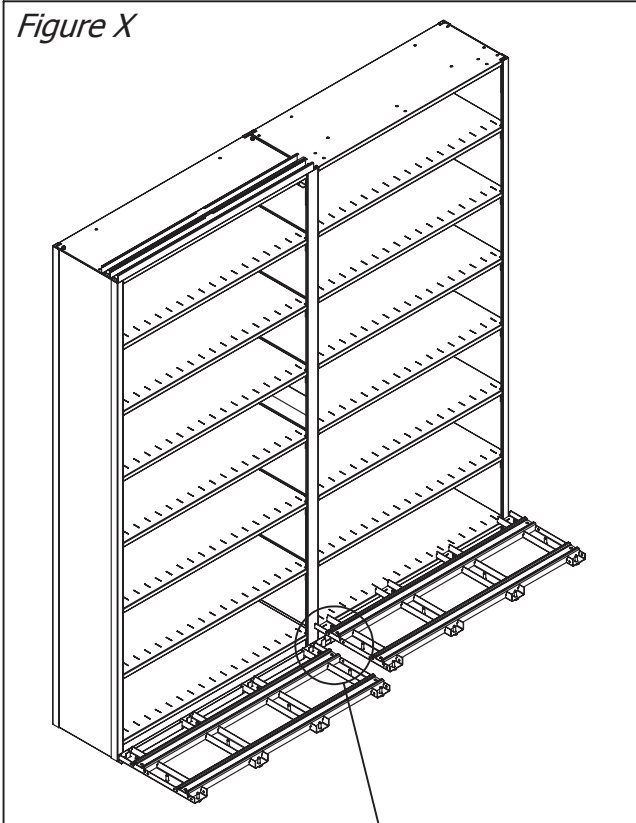


Step 16:

Install (12) leveling glides in each rail assembly making sure that each glide is screwed in completely and is flush with the bottom of the rail assembly (See Figure W).



Figure X



Step 17:

Attach a rail assembly to each stationary connector channel. Rail assemblies have corresponding slots which slide over connector channel to secure rail assembly into place (See Figure X and Detail Y).

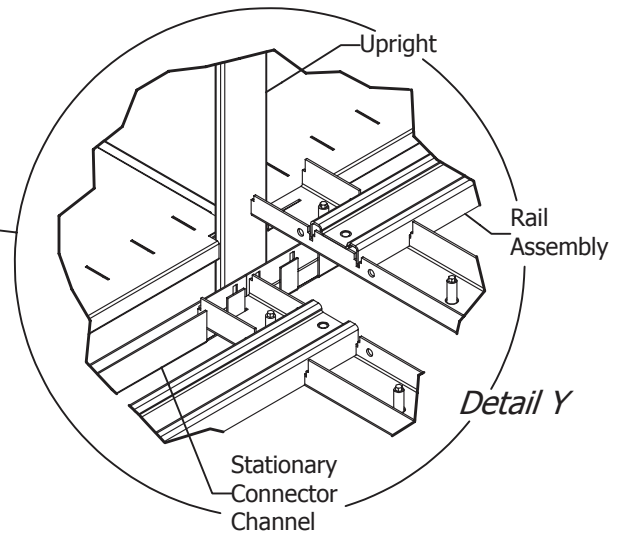
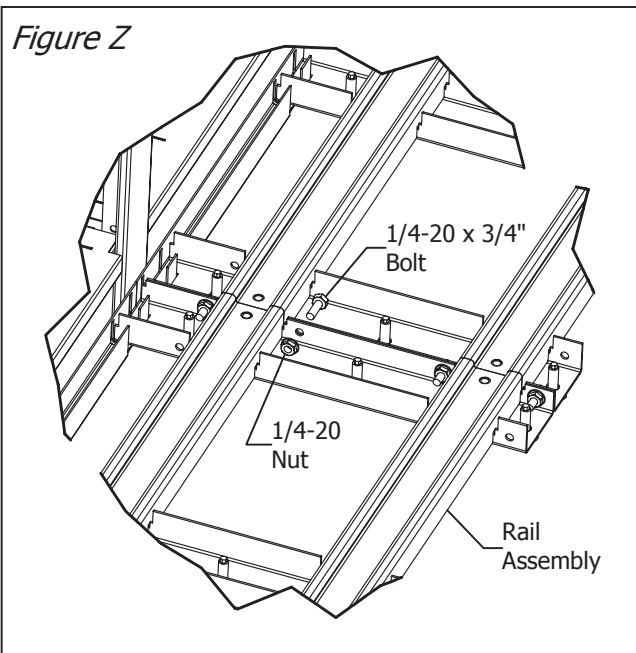


Figure Z



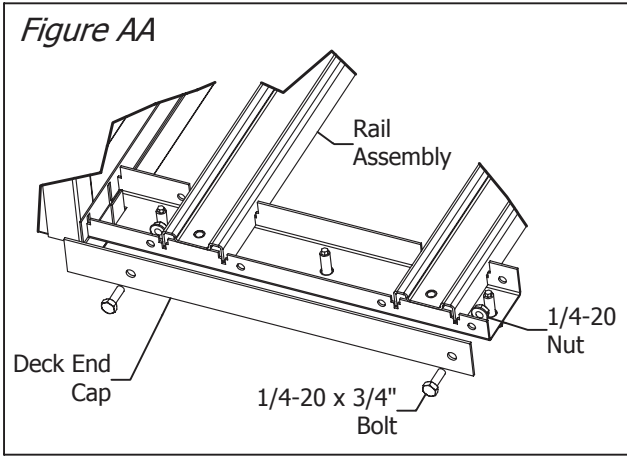
Step 18:

Join rail assemblies together using (4) 1/4-20 x 3/4" hex bolts and (4) flanged hex nuts. Make sure rails are flush from one assembly to the next before tightening bolts (See Figure Z).

- For BiSlider Systems, continue with Step 19
- For TriSlider Systems, skip to Step 20
- For QuadSlider Systems, skip to Step 22



Figure AA

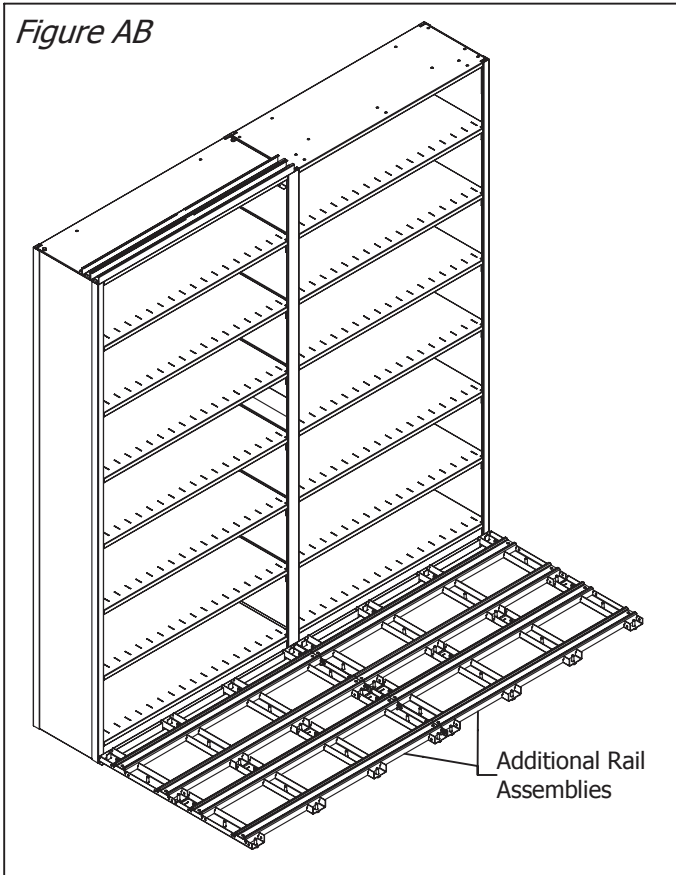


Step 19: For Bi-Slider Systems Only

Attach deck end cap to rail assembly starting from left end of rail assembly. Use (2) 1/4-20 x 3/4" hex bolts and (2) 1/4-20 flanged hex nuts to secure end cap to rail assembly as shown in Figure AA. Repeat for right side of system.

Skip to Step 24.

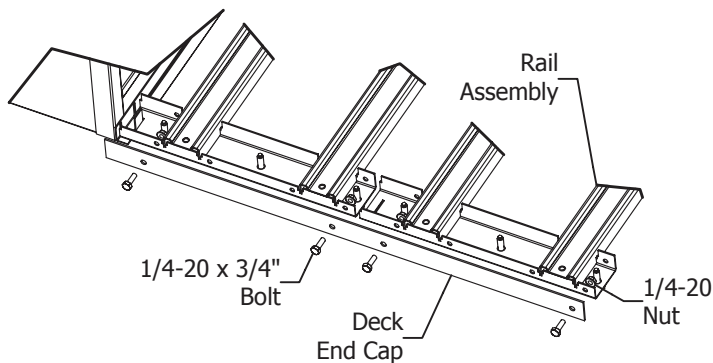
Figure AB



Step 20: For TriSlider Systems Only

Position additional row of rail assemblies in front of Bi-Slider rail assemblies that were already in place as shown in Figure AB. Join second row of rail assemblies to each other with 1/4-20 hardware as instructed in **Step 18** for first set of rails.

Figure AC



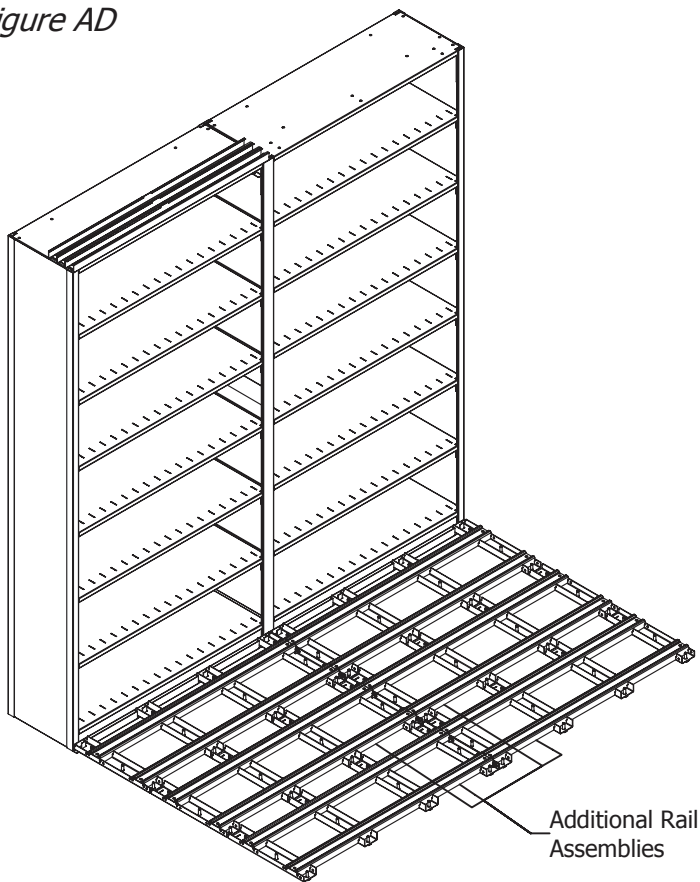
Step 21: For TriSlider Systems Only

Attach deck end cap to rail assemblies starting from left end of rail assembly. Use (4) 1/4-20 x 3/4" hex bolts and (4) 1/4-20 flanged hex nuts to secure end cap to rail assembly as shown in Figure AC. Repeat for right side of system.

Skip to Step 24.



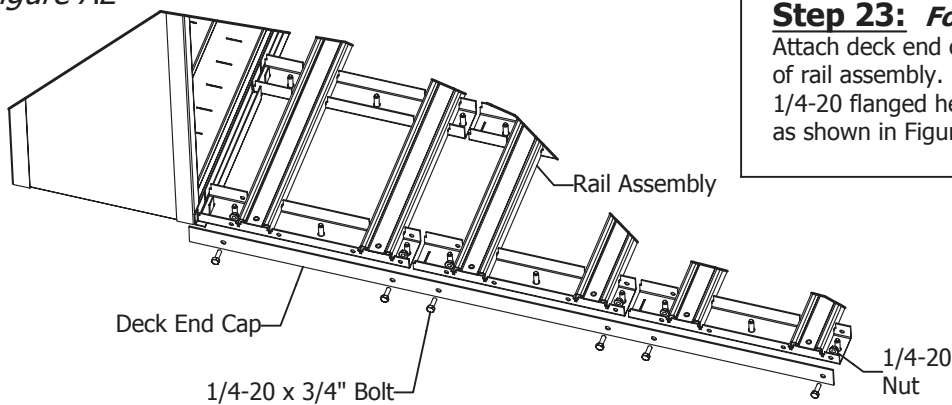
Figure AD



Step 22: For QuadSlider Systems Only

Position (2) additional rows of rail assemblies in front of Bi-Slider rail assemblies that were already in place as shown in Figure AD. Join second & third rows of rail assemblies to each other with 1/4-20 hardware as instructed in **Step 18** for first set of rails.

Figure AE



Step 23: For QuadSlider Systems Only

Attach deck end cap to rail assemblies starting from left end of rail assembly. Use (6) 1/4-20 x 3/4" hex bolts and (6) 1/4-20 flanged hex nuts to secure end cap to rail assembly as shown in Figure AE. Repeat for right side of system.



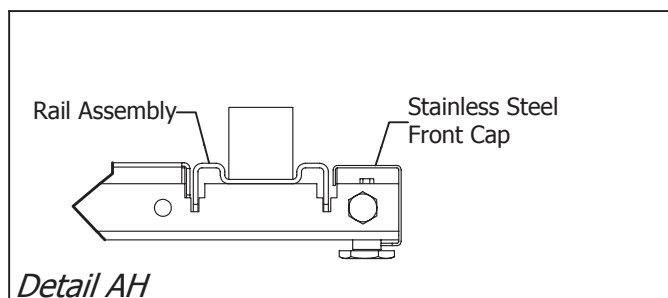
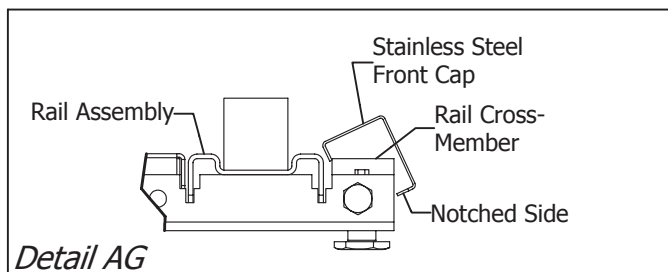
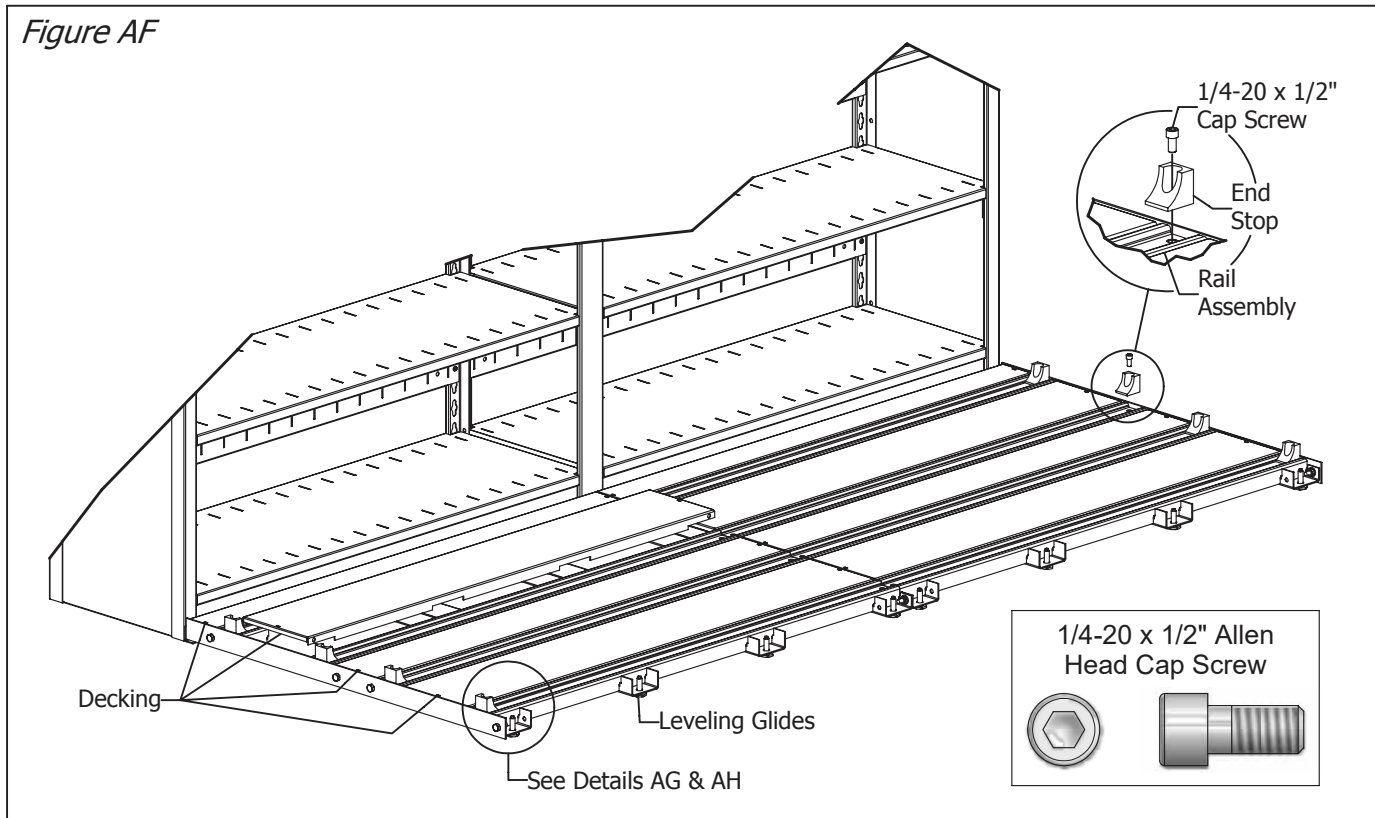
Step 24: LEVELING OF UNIT

Determine highest point on rail assembly. Working out from this point, level rails by adjusting leveling glides. **For system to function properly all rails must be level from left-to-right, front-to-back, and rail-to-rail. All leveling glides must be in contact with the floor.**

Step 25:

Install unit decking. Deck sections interlock with rail assemblies and should be flush with the top of the rails when installed (See Figure AF). After decking is in place, install end stops at the end of each rail using (1) 1/4-20 x 1/2" cap screw (See Figure AF).

Figure AF

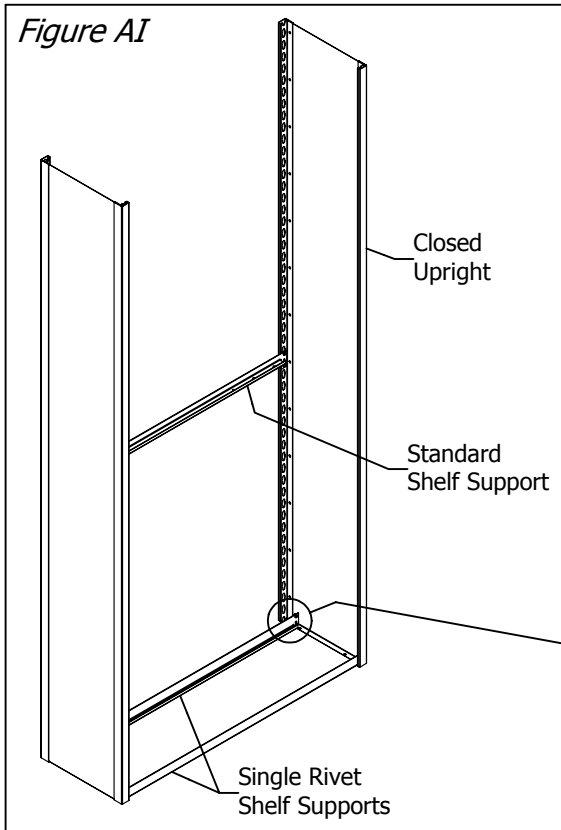


Step 26:

Remove protective film from stainless steel front cap **before** attaching to rail assembly. Position cap with notches towards floor, then attach to each rail section by snapping into place over front rail crossmembers (See Details AG & AH).



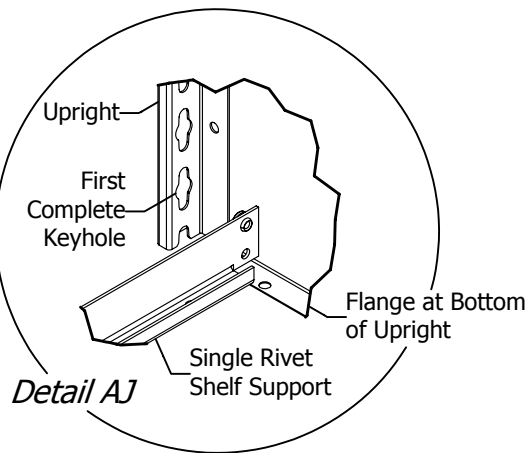
Figure AI



Step 27:

Temporarily mount a shelf support at chest height between (2) closed 'L' uprights to hold them in position. Check to make certain that the flanges on the uprights are at the bottom of the unit. Mount (2) single rivet shelf supports into the first complete set of keyholes at the bottom of the uprights (See Figure AI & Detail AJ).

Note: Single rivet shelf supports are used **only** for the bottom shelf on units that will be attached to a carriage. Standard shelf supports are used for the rest of the unit.



Note:

All mobile carriages are preset at the factory to include 2" of overtravel. Systems up to a 4/3 configuration for Bi/Tri/Quad do not require overtravel. Overtravel can be increased or decreased as needed for your specific application. Please refer to the diagram above for more information. (See Figure Y).

Proper Placement Of Carriage Wheels For Overtravel

Placement of Wheel Assembly for 4" Overtravel (Inside Holes). For Systems Up To 7/6 Configurations.

Standard Placement of Wheel Assembly for 2" Overtravel (Center Holes). No Need to Adjust for Systems up to a 5/4 Bi/Ti/Quad Configuration.

Placement of Wheel Assembly for No Overtravel (Outside Holes). Adjustable if Necessary up to a 3/2 Bi/Tri/Quad Configuration.

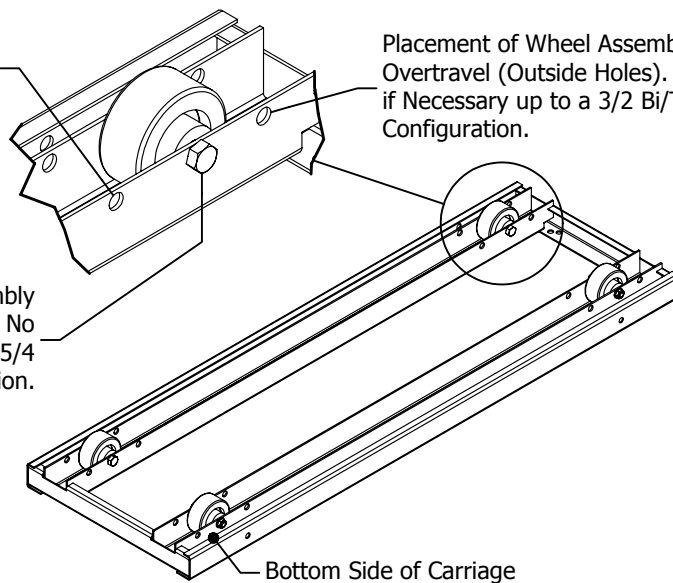
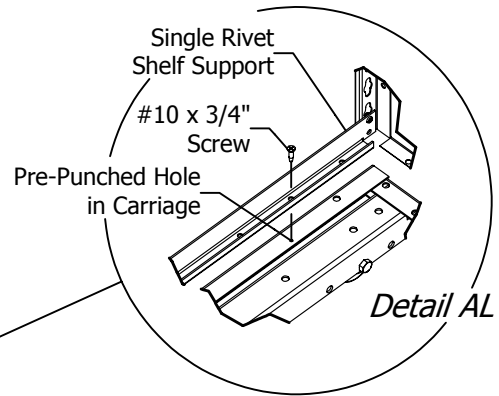
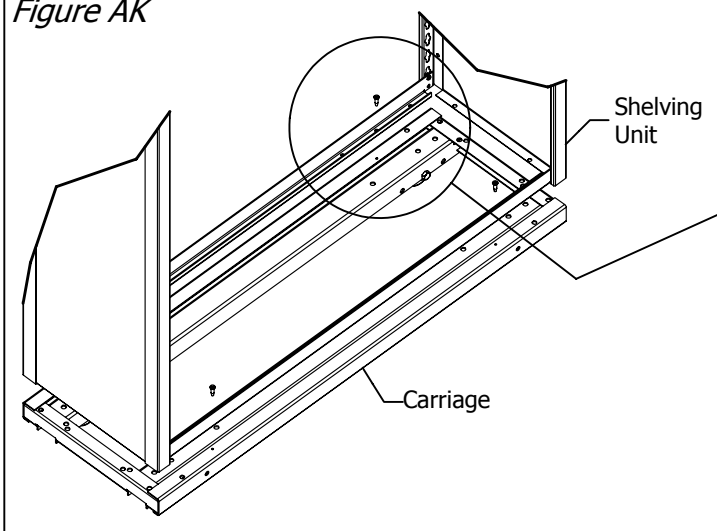


Figure AK



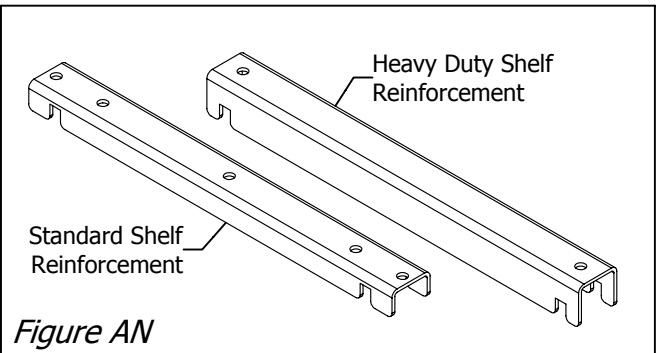
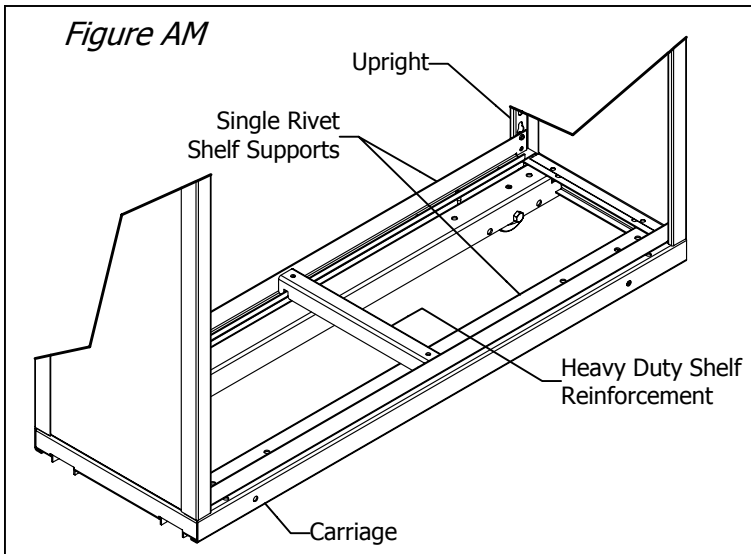
Step 28:

Fasten the shelving unit assembled in the previous step to a carriage using (4) #10 x 3/4" flat head tek screws (See Figure AK & Detail AL).

#10 x 3/4" Flat Head Tek Screw



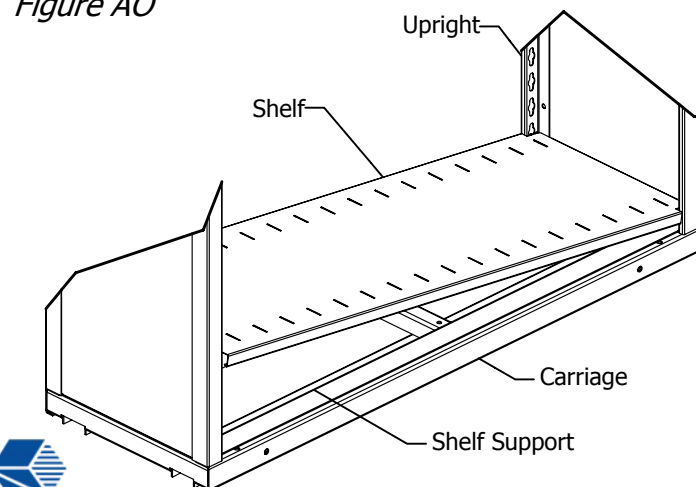
Figure AM



Step 29:

Install heavy duty shelf reinforcements for the bottom shelf as shown in Figure AM. See Table 2 for proper number of reinforcements. Figure AN shows the visual difference of a standard shelf reinforcement compared to a heavy duty reinforcement.

Figure AO



Depth of Shelving	Number of Heavy Duty Reinforcements
12"	None
15"	None
18"	One

Step 30:

Install bottom shelf by tilting as shown in Figure AO. It should then lie flat on shelf supports and reinforcement(s).



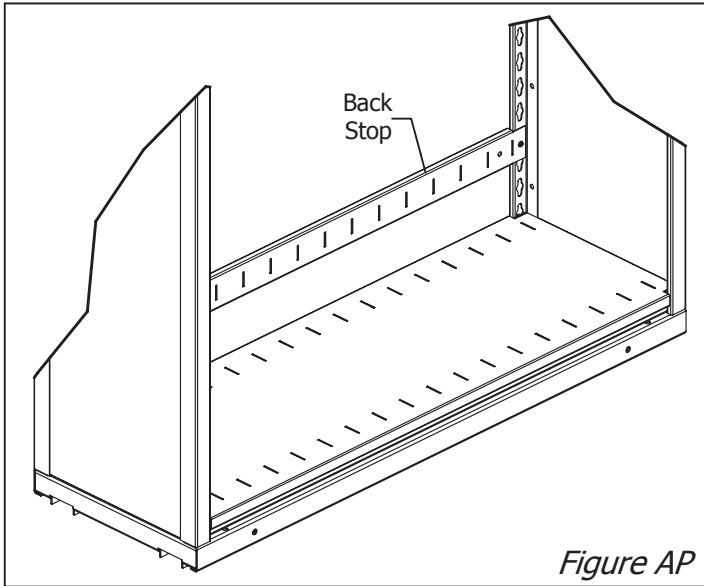


Figure AP

Step 31:

Install back stop for bottom shelf. Count up three complete keyholes from top of shelf and place rivets of back stop into these keyholes (See Figure AP).

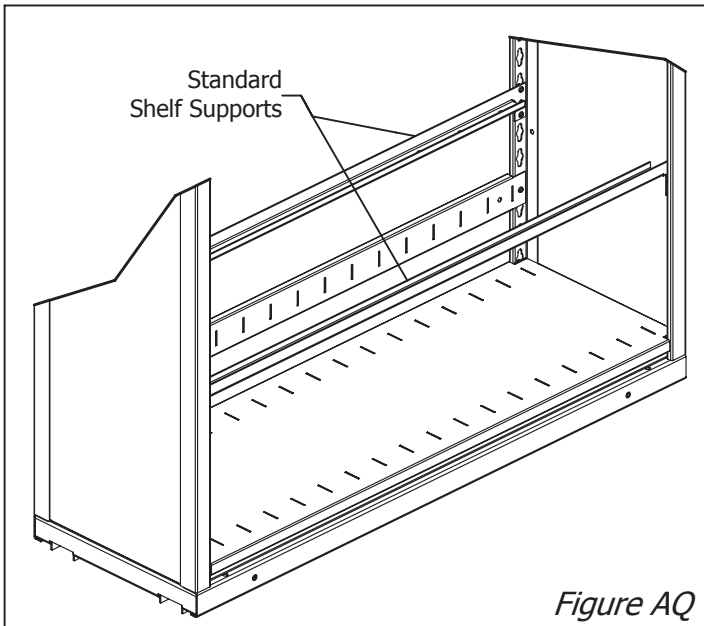


Figure AQ

Step 32:

Install (2) standard shelf supports at the correct locations based on unit configuration. See Figure F on Sheet 5 for guidance on shelf spacing.

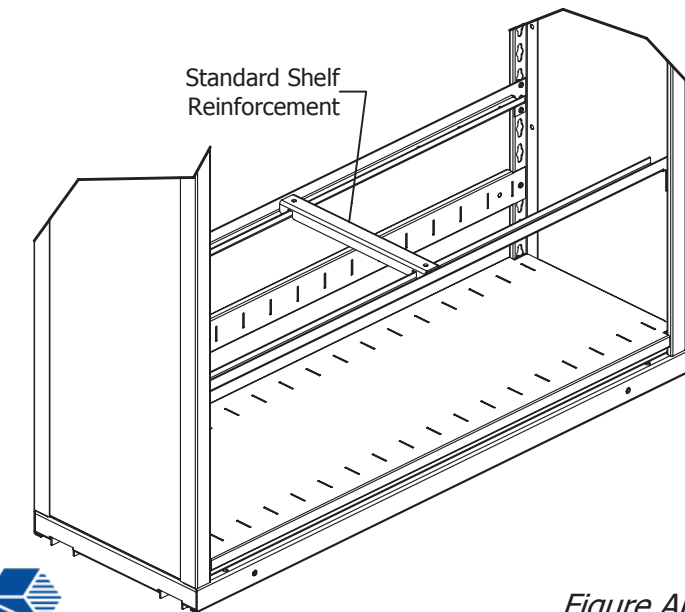


Figure AR

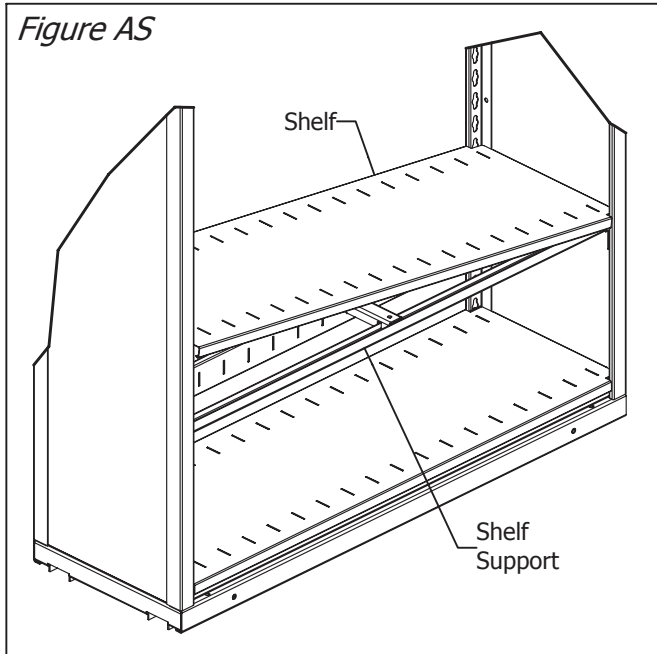
Step 33:

If required (See Table 3) install standard shelf reinforcement(s) as shown in Figure AR.

Depth of Shelving	Number of Reinforcements/Shelf
12"	None
15"	None
18"	Two



Figure AS



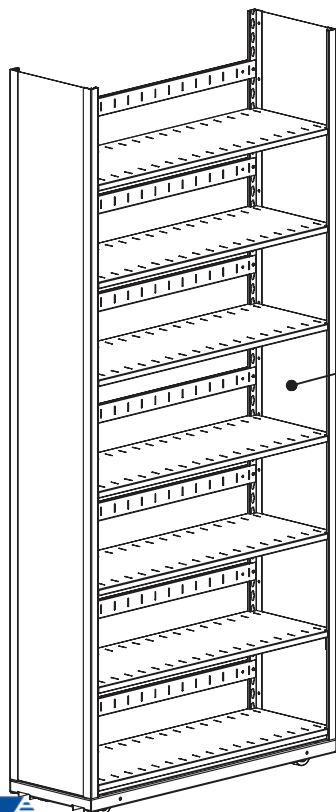
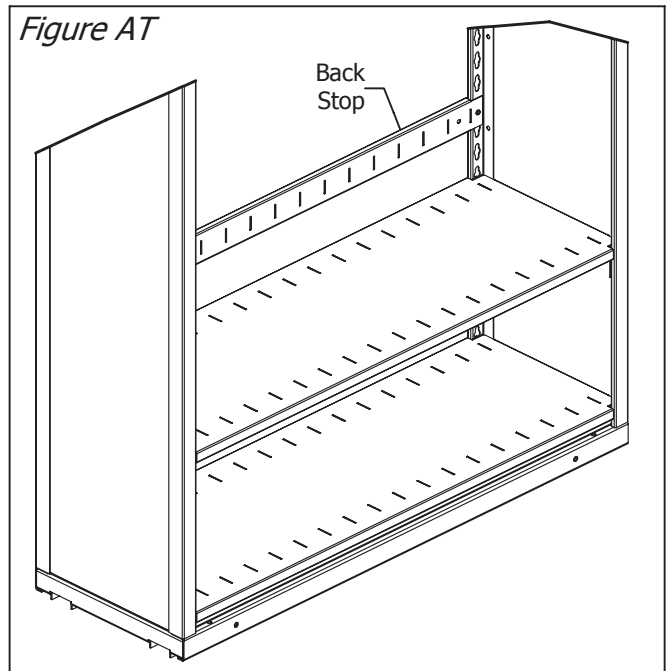
Step 34:

Install second shelf by tilting as shown in Figure AS. It should then lie flat on shelf supports and reinforcement(s).

Step 35:

Install back stop for second shelf. Count up three complete keyholes from top of shelf and place rivets of back stop into these keyholes (See Figure AT).

Figure AT



Fourth Opening Typically Has Posting Shelf on Letter/Legal Systems

Figure AU

Step 36:

Install remainder of shelf supports, shelves, back stops, & shelf reinforcements (if required), working from bottom to top. Keep in mind your installation may be different, as shelf spacing varies from job to job (See Figure F on Sheet 5 for typical configurations). Do not install components at the top of unit at this time; when complete the assembled unit should look similar to Figure AU.



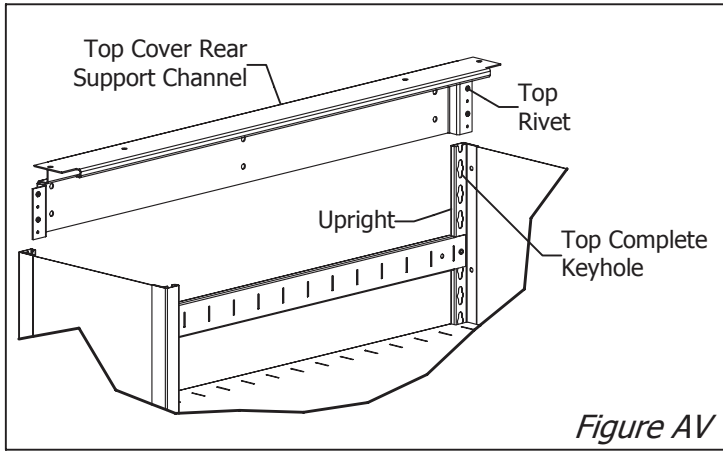


Figure AV

Step 37:

Place the rivets of the top cover rear support channel into the keyholes at the top of the upright at the rear of the unit. The top rivet on each side should be inserted into the first complete keyhole at the top of the uprights (See Figure AV). Tap channel into place with rubber mallet or hammer to seat rivets firmly into bottom of keyholes.

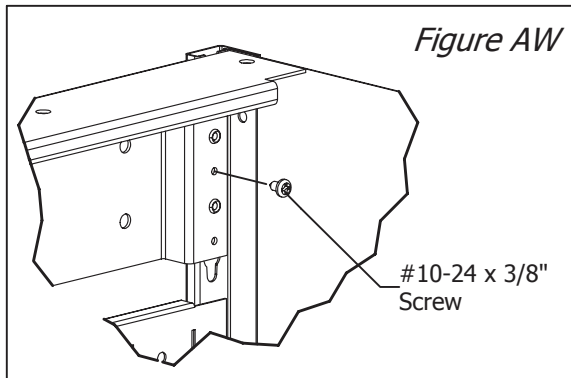


Figure AW

Step 38:

Use (2) #10-24 x 3/8" phillips pan head screws to secure channel to uprights as shown in Figure AW.

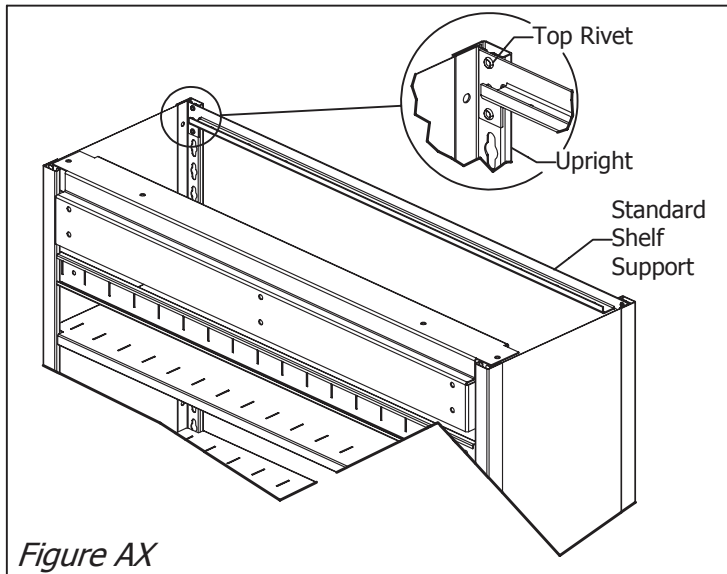
#10-24 x 3/8" Phillips Pan Head Sheet Metal Screw



Note:

For BiSlider carriage assembly, continue with Step 39. However, if you have finished assembling all BiSlider carriages and are now assembling Tri-QuadSlider carriages, skip forward to Step 50.

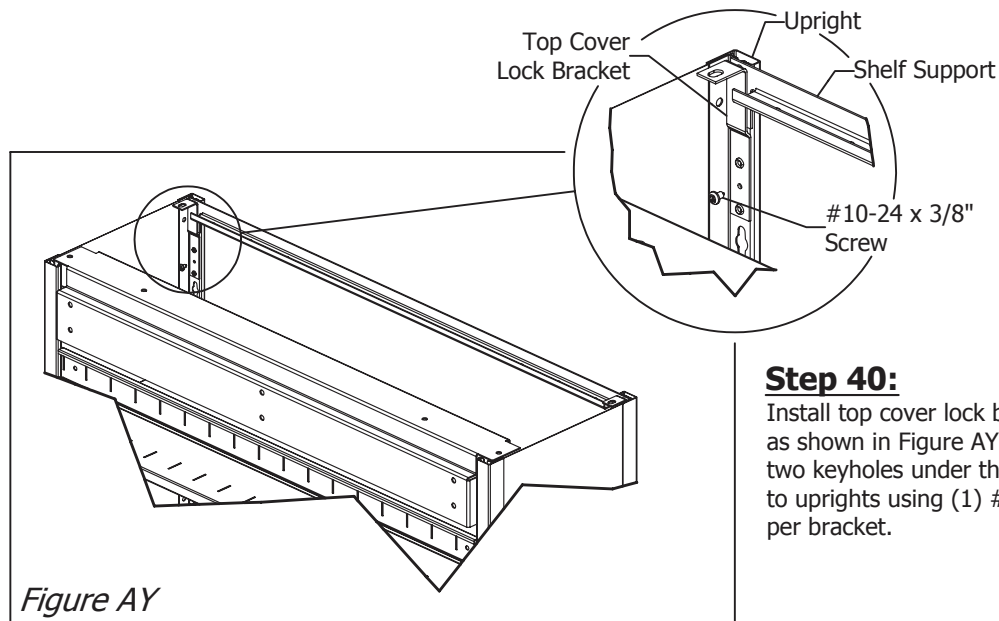




Step 39:

Install a standard shelf support at the top front of the unit uprights as shown in Figure AX. Place the top rivet on each side of support into the top most keyhole of the uprights. Tap support bracket with rubber mallet or hammer to seat rivets into bottom of keyholes.

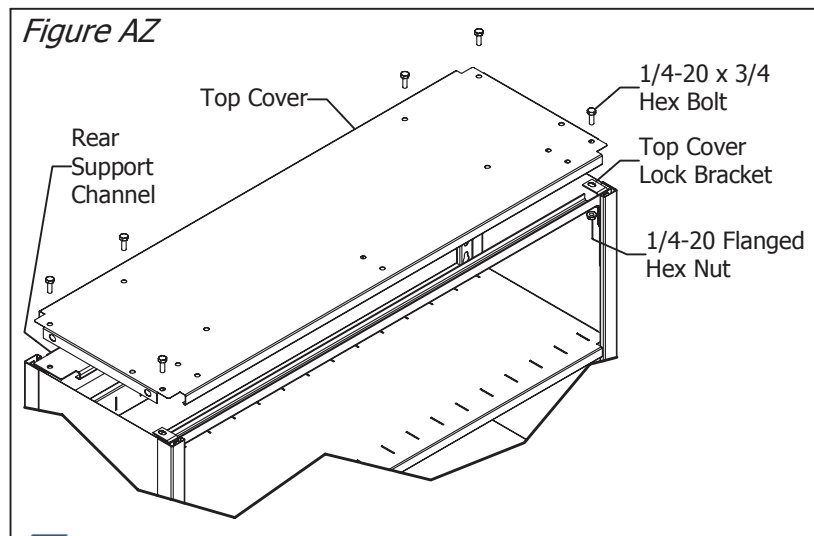
Figure AX



Step 40:

Install top cover lock brackets into the front of both uprights as shown in Figure AY. Place rivets of lock brackets into first two keyholes under the shelf support. Secure lock brackets to uprights using (1) #10-24 x 3/8 phillips pan head screw per bracket.

Figure AY



Step 41:

Place cover on top of unit and secure to rear support channel and both top cover lock brackets using 1/4-20 hardware as shown in Figure AZ.

Figure AZ



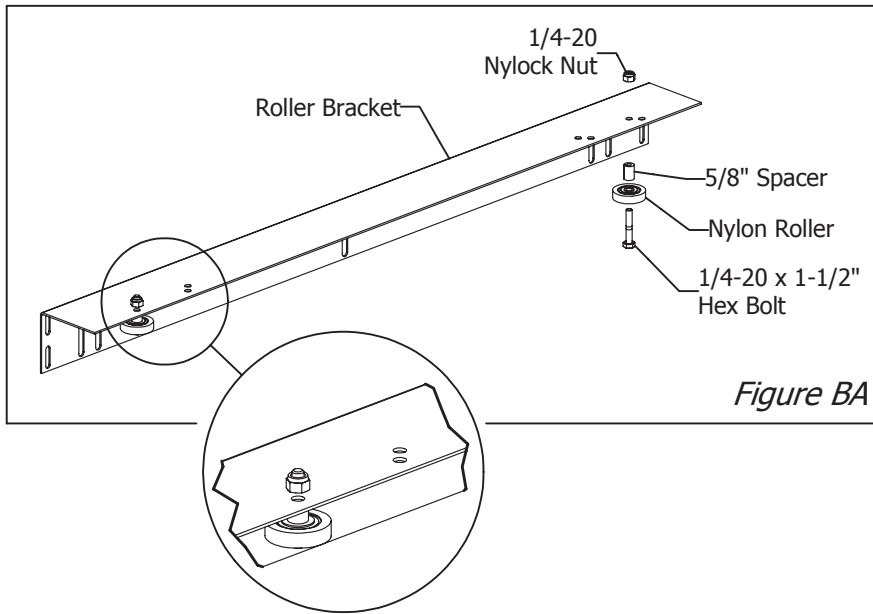


Figure BA

Note:

Assembly of BiSlider roller bracket will depend on how much overtravel is required for your system. If your system is a 6/5 or smaller, proceed with Step 42. If your system is a 7/6 or larger, skip to step 43.

Step 42:

Assemble BiSlider roller bracket as shown in Figure BA for units with 0-2" of overtravel (6/5 or smaller units). Skip forward to Step 44.

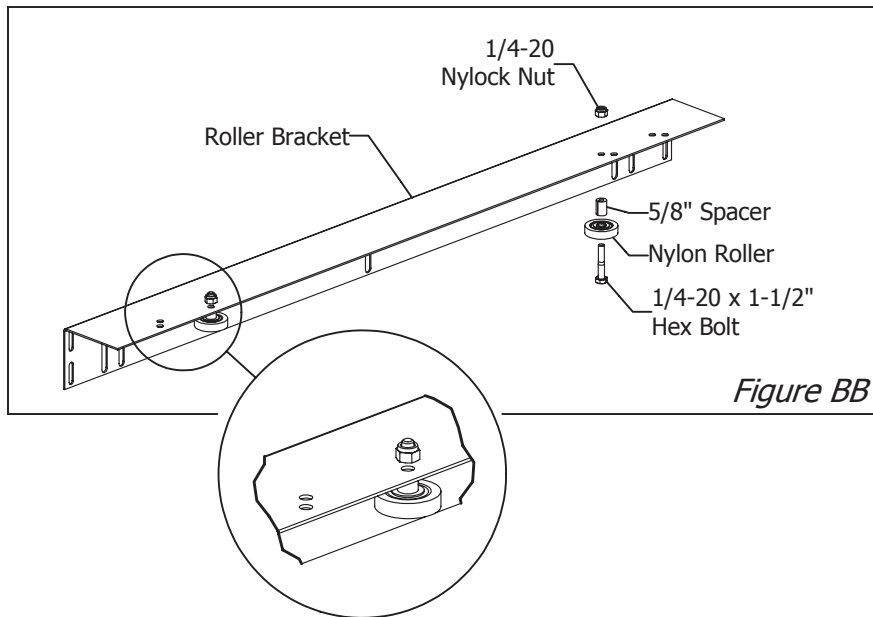


Figure BB

Step 43:

Assemble BiSlider roller bracket as shown in Figure BB for units with 4" of overtravel (7/6 or larger units).

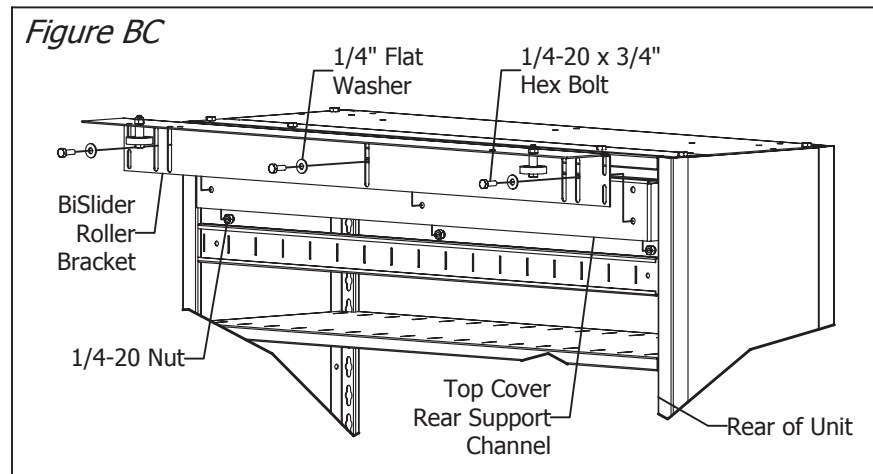
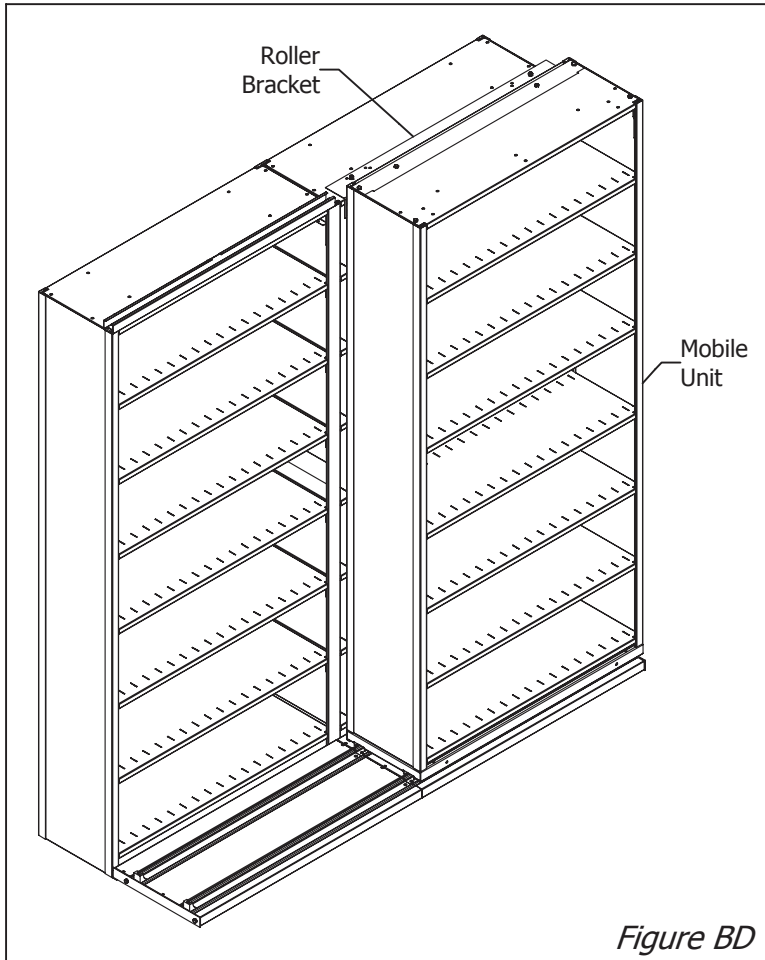


Figure BC

Step 44:

Attach assembled BiSlider roller bracket to the rear of shelving unit using (3 each) of 1/4-20 x 3/4 hex head bolt, 1/4" flat washer, and 1/4-20 Nylock Nut (See Figure BC). Leave bolts loose enough to allow adjustment of roller bracket when mobile unit is placed on rail assembly.



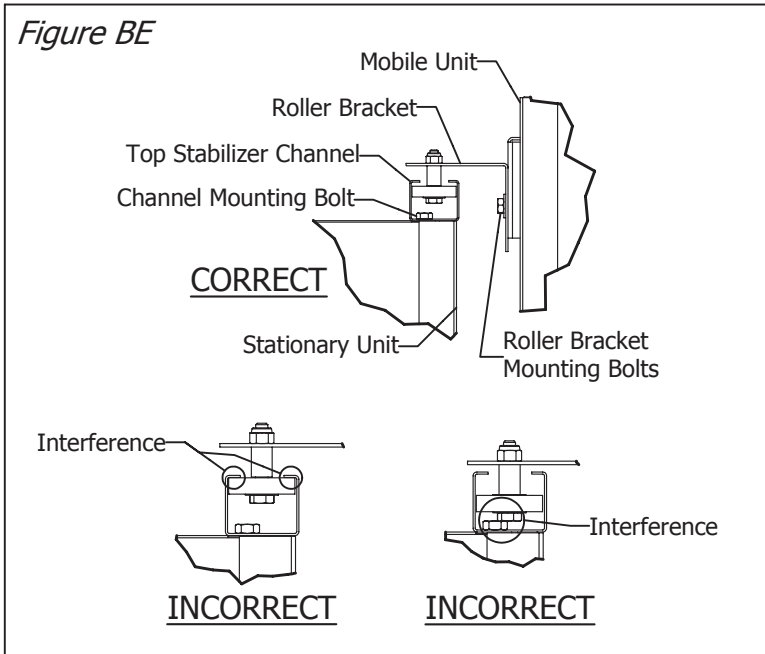


Step 45:

Place assembled mobile unit on tracks of rail assembly in front of stationary unit that does not have a top stabilizer channel installed (See Figure BD).

Figure BD

Figure BE

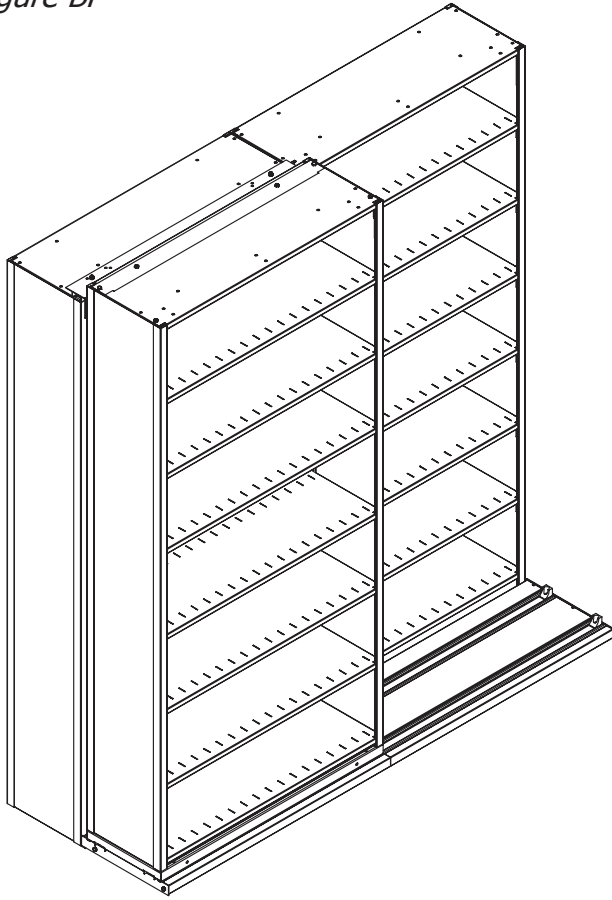


Step 46:

Adjust height of roller bracket as correctly shown in Figure BE to eliminate any interference with top of stabilizer channel of with the stabilizer channel mounting brackets. Once height of roller bracket is properly set, tighten roller bracket mounting bolts.



Figure BF



Step 47:

Move mobile unit so that the roller bracket is completely engaged within the row of installed top stabilizer channels on the stationary units as shown in Figure BF.

Step 48:

Assemble all remaining BiSlider carriage/shelving units by repeating steps 27 through 47. Once all BiSlider units have been assembled continue with Step 49 to assemble and install Tri/QuadSlider units if necessary. If your system does not include any Tri/QuadSlider units, skip forward to Step 62 for final assembly of the system.



Note:

This section of the instructions is for Tri/QuadSlider systems only. For TriSlider systems, repeat steps 49 through 58 until all TriSlider units are in place and then proceed to Step 62 for final assembly. For QuadSlider systems repeat steps 49 through 58 to install all TriSlider units first and then repeat steps 49 through 61 for all QuadSlide units, then proceed to Step 62 for final assembly.

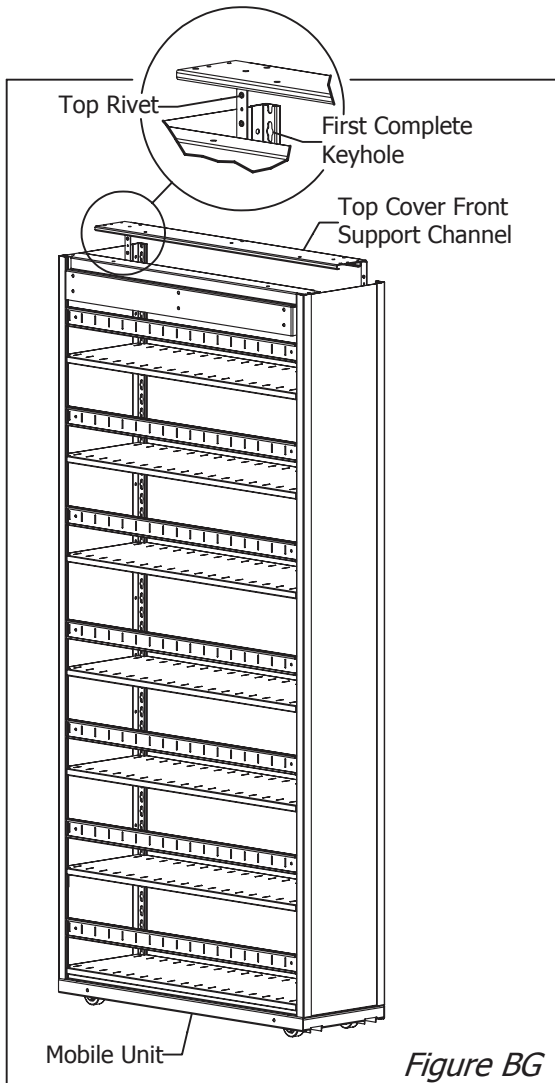


Figure BG

Step 49:

Begin assembly of a new mobile unit by following Steps 27 through 38.

Step 50:

Install top cover front support channel by placing top rivet on each side of channel into the first complete keyhole in the top of both uprights as shown in Figure BG.

Step 51:

Secure top cover front support channel to both uprights using #10-24 x 3/8" screws as shown in Figure BH.

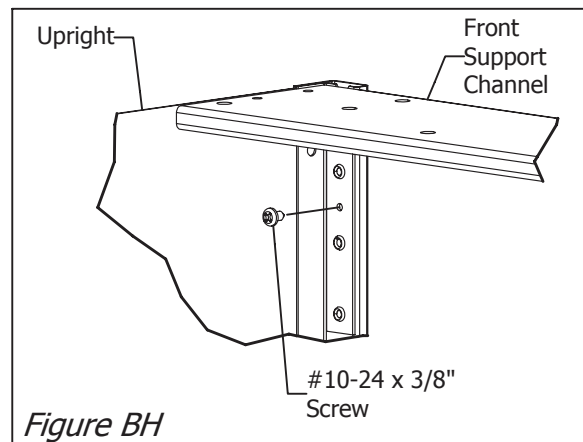


Figure BH

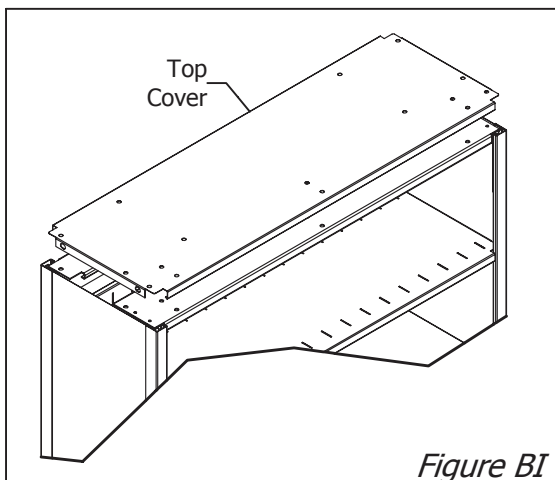


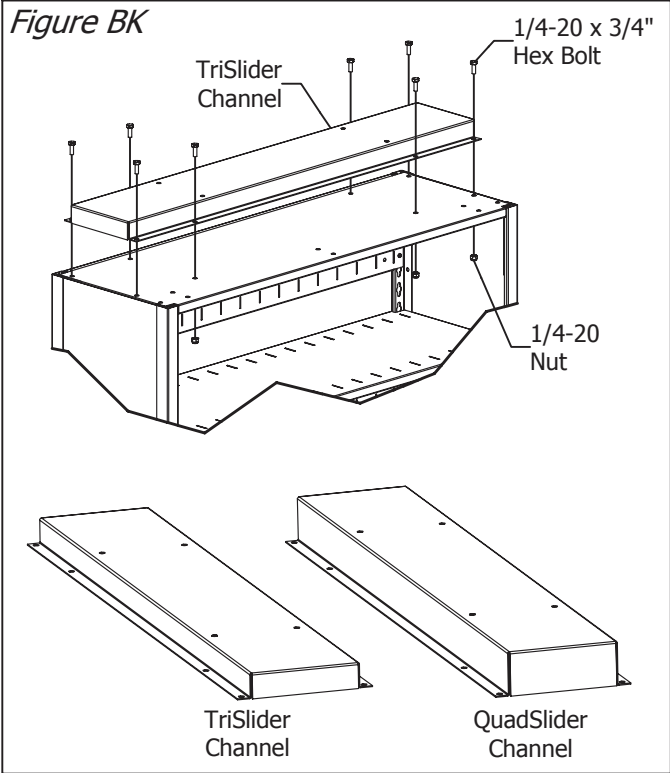
Figure BI

Step 52:

Place top cover on top of unit as shown in Figure BI.



Figure BK



Note:

If your system contains Quadslider units, make sure to use the appropriate components in Steps 53 & 54 as the TriSlider and QuadSlider hat channels, top stabilizer, and roller assemblies are very similar. The TriSlider hat channel is the shorter of the two (see Figure BK). The TriSlider top stabilizer panel is also the shorter of the two top panels. The TriSlider roller assembly has (2) rollers compared to (4) rollers on the QuadSlider assembly.

Step 53:

Attach TriSlider hat channel to top panel using (8) 1/4-20 x 3/4" hex bolts and (8) 1/4-20 nylock nuts as shown in Figure BK.

Step 54:

Attach TriSlider roller mount assembly to TriSlider top stabilizer panel using 1/4-20 hardware as shown in Figure BL.

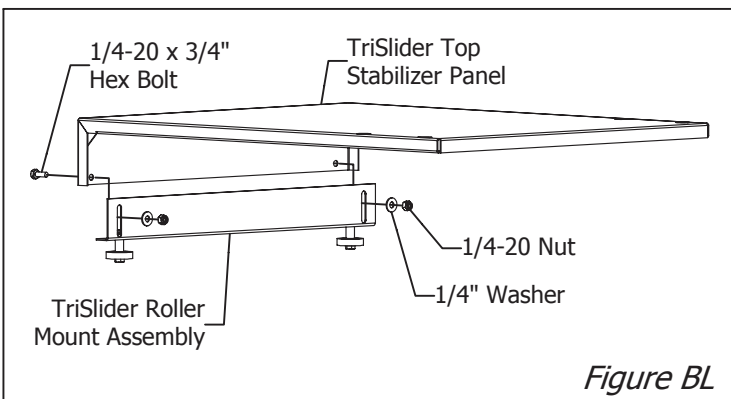


Figure BL

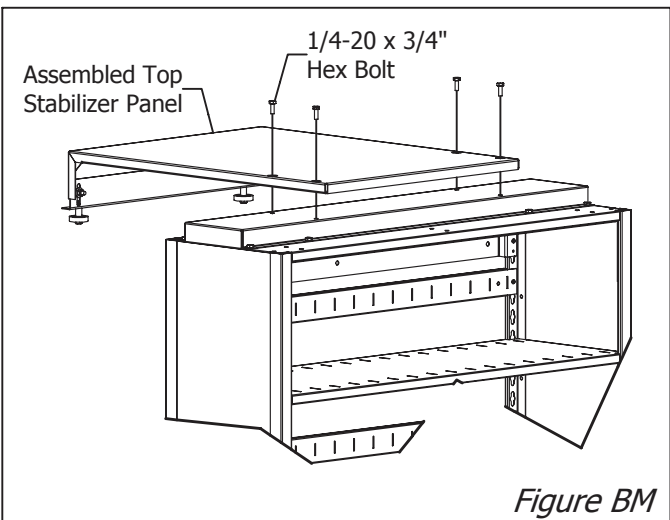


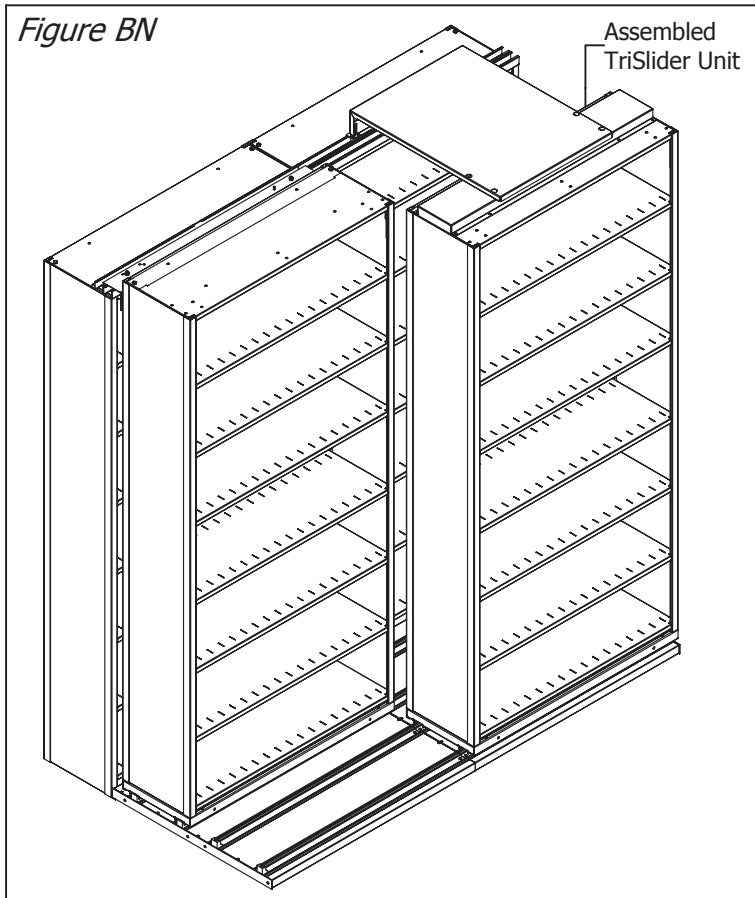
Figure BM

Step 55:

Attach assembled TriSlider top stabilizer panel to top of unit using (4) 1/4-20 x 3/4" hex bolts as shown in Figure BM.



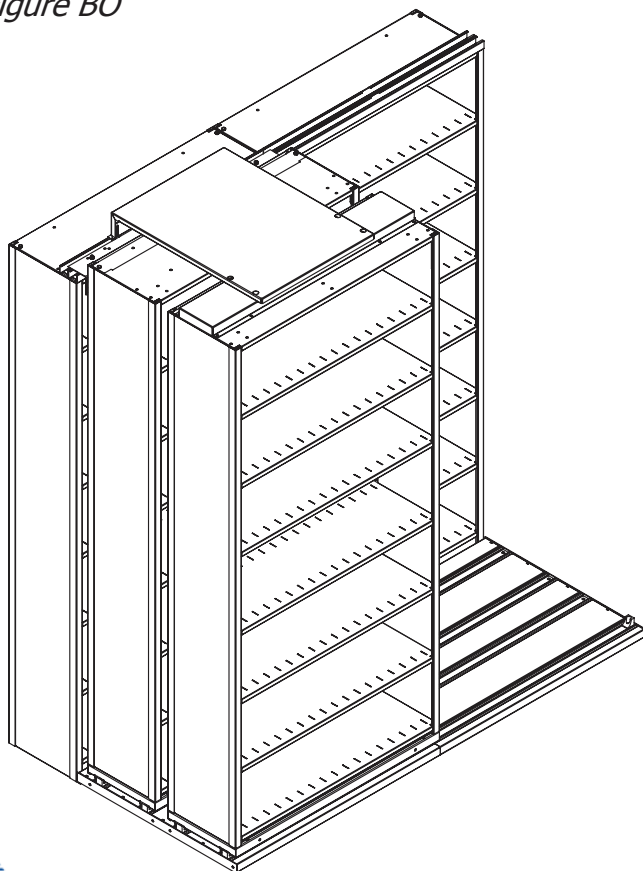
Figure BN



Step 56:

Place assembled TriSlider unit onto rails as shown in Figure BN. Align roller bracket with top stabilizer channel on stationary units the same way as shown for BiSlider units in Figure BE.

Figure BO



Step 57:

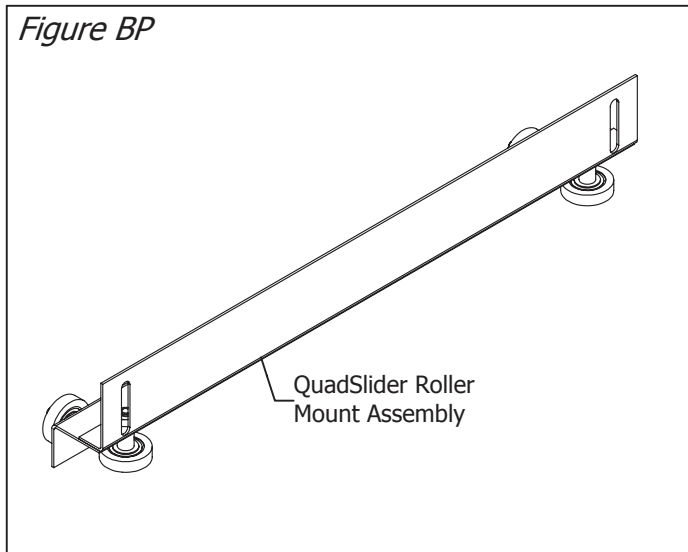
Move TriSlider unit so that the roller bracket is completely engaged within the row of installed top stabilizer channels on the stationary units as shown in Figure BO.

Step 58:

Assemble all remaining TriSlider carriage/shelving units by repeating steps 49 through 57. Once all TriSlider units have been assembled continue with Step 59 to assemble and install QuadSlider units if necessary. If your system does not include any QuadSlider units, skip forward to Step 62 for final assembly of the system.



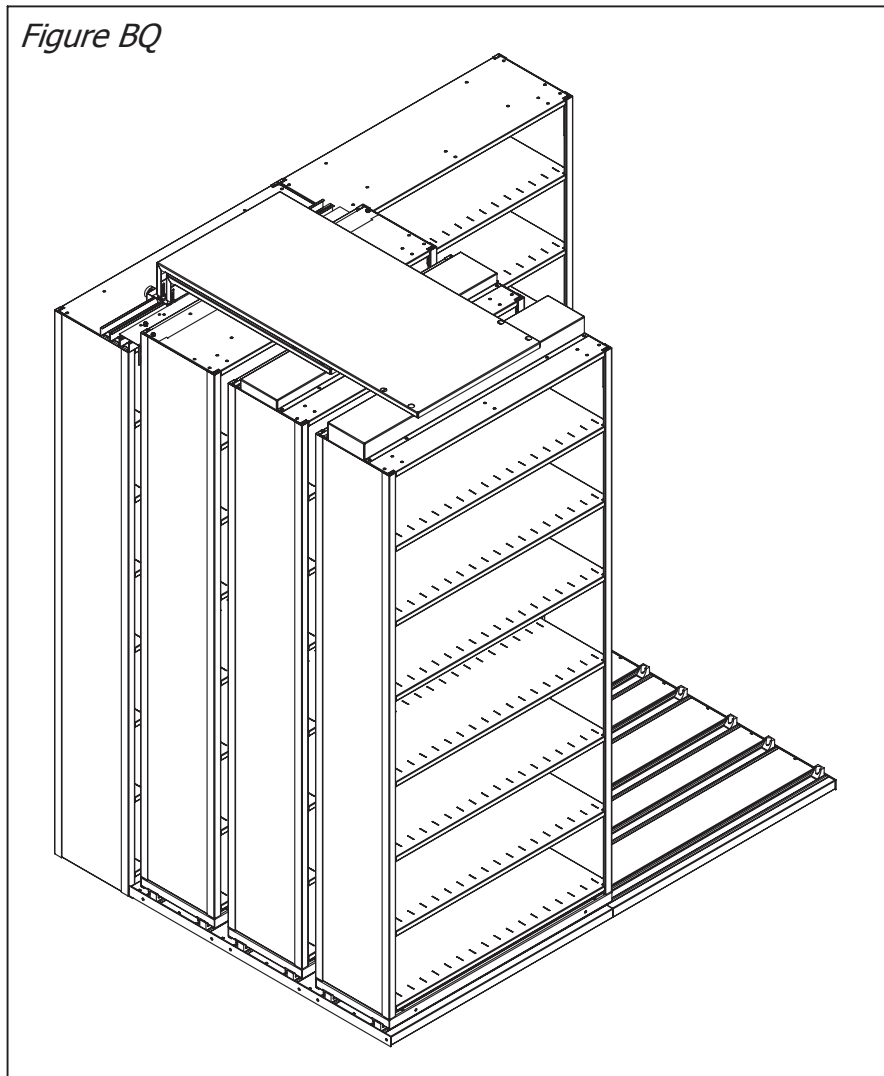
Figure BP



Step 59:

Begin assembly of a new QuadSlider mobile unit by following Steps 49 through 55. For Steps 53, 54, & 55, be sure to use the correct QuadSlider components in place of TriSlider components (Figure BP shows correct QuadSlider roller mount assembly with (4) rollers).

Figure BQ



Step 60:

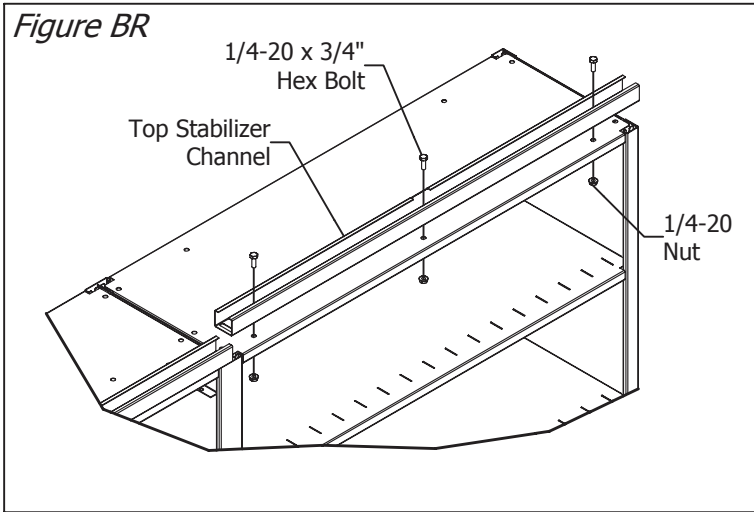
Place assembled QuadSlider unit onto rails. Align roller bracket with top stabilizer channel on stationary units the same way as shown for BiSlider units in Figure BE. Move QuadSlider unit so that the roller bracket is completely engaged within the row of installed top stabilizer channels on the stationary units as shown in Figure BQ.

Step 61:

Assemble all remaining QuadSlide carriage/shelving units by repeating steps 59 through 60. Once all QuadSlide units have been assembled continue with Step 62 for final assembly of the system.



Figure BR



Step 62:

Attach remainder of top stabilizer channels to stationary units with 1/4-20 x 3/4" hex bolts and 1/4-20 flanged hex nuts. Refer to Figure BR for BiSlider systems; Figure BS for TriSlider systems; and Figure BT for QuadSlider systems.

Figure BS

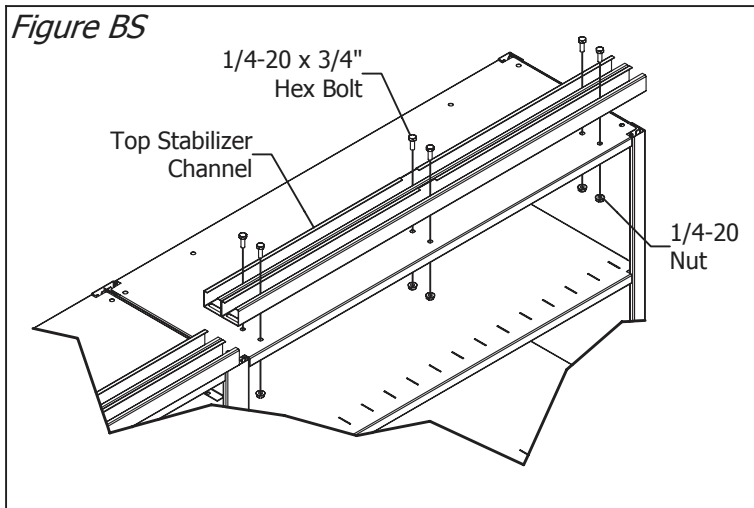
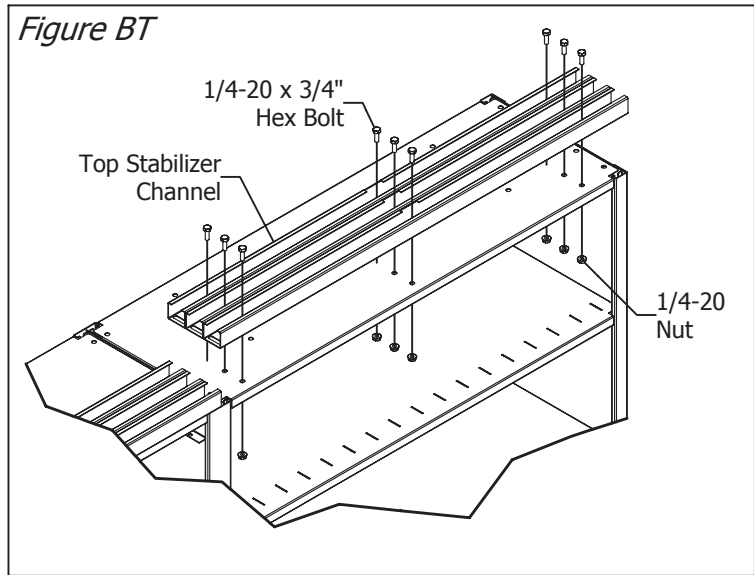
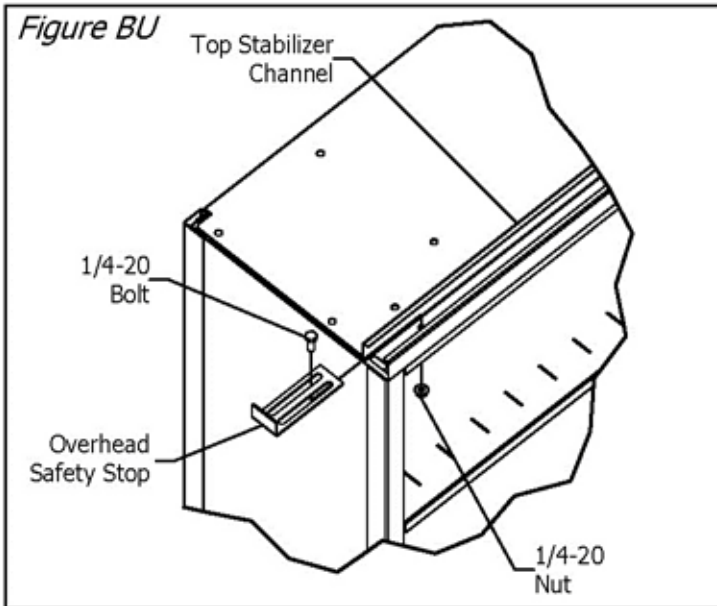


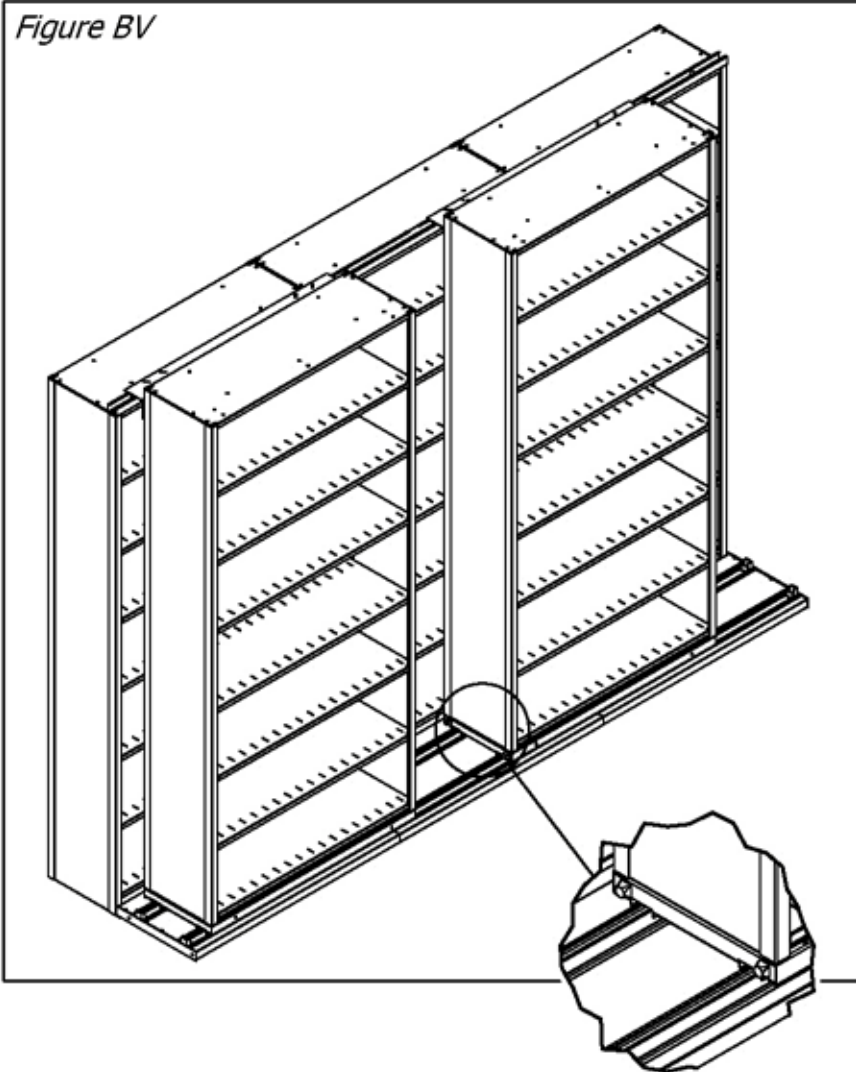
Figure BT





Step 63:

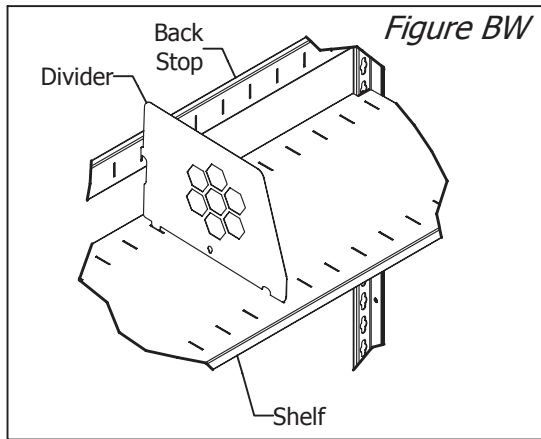
Remove (1) 1/4-20 x 3/4" hex bolt and nut from far left and far right of each top stabilizer channel. Insert overhead safety stop into stabilizer channel and secure using the same 1/4-20 hardware as shown in Figure BU.



Step 64:

Attach (1) pair of self-adhesive rubber bumpers between each pair of mobile units as shown in Figure BV.





Step 65:

Install dividers as needed. Hook front tab of divider into front slot of shelf, then slide divider back and hook top rear tab into the into the back stop (See Figure BW).

SAFETY PRECAUTIONS:

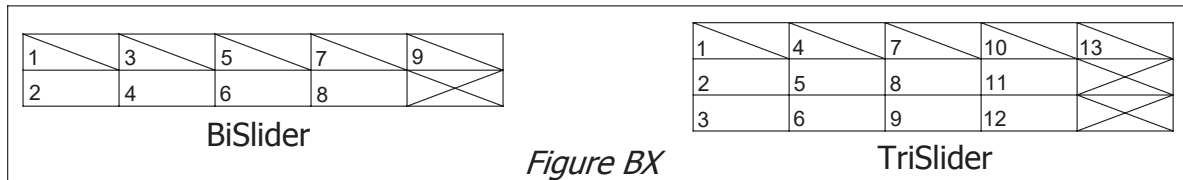
- 1) Read through these instructions again insuring that all steps were completed.
- 2) Recheck & tighten any loose bolts or fittings.
- 3) Check to see that all Top Stabilizer Channels are securely fastened to the tops of the Stationary Sections.
- 4) Check to insure that the End Stops are securely fastened to the Rail Assemblies.
- 5) If attaching Stationary Section to wall, make sure to follow manufacturer's recommendations.

LOADING THE SYSTEM:

Loading a Bi/TriSlider system in the correct manner is very important. It balances the paper weight load throughout the entire system & minimizes the odds of having to move the rolling sections every time the system is accessed. Careful planning of this phase of the installation will make filing & retrieval a lot easier.

It is recommended the system be loaded first from the left rear section followed by the first rolling section on the left side of the BiSlider. If a TriSlider is installed, next load the first rolling section on the left side of the front row (see *Figure BX*).

Repeat loading from the rear to the front until completed. Load all shelving from the bottom up.



RE-LEVELING THE BI/TRI SLIDER SYSTEM:

It rarely occurs; however, after the Bi/TriSlider system has been loaded, the rolling sections may begin to move or creep on their own. While this problem is more annoying than hazardous, it may be corrected by re-leveling the Rail Assembly. The Datum Bi/TriSlider system has been designed so that the Deck Plates can be easily removed for access to the Leveling Glides.

To remove the Deck Plates, move the rolling sections to one side. Then, insert a slotted screw driver into the slot provided on the Decking & with even pressure pull the Deck Plates up & remove.

Next, re-adjust the Leveling Glides by turning them one-quarter turn at a time either raising or lowering the Rail Assembly to the desired height to stop the unwanted movement. It is very important that all Leveling Glides maintain contact with the floor. When this adjustment has been completed, re-install the Deck Plates.

Thank you for purchasing & installing this Slider System.

