

ROLLED PLAN FILE ORGANIZER

ASSEMBLY INSTRUCTIONS

PARTS LIST			
LETTER CODE	DESCRIPTION	QTY.	PART NO.
(A)	Shell	1	3081-01
(B)	Pad	1	3081-02
(C)	Rectangular Partition (Short, Model 3079)	1	3079-23A
(D)	Rectangular Partition (Tall, Model 3079)	1	3079-23B
(E)	Rectangular Partition (Short, Model 3081)	1	3081-23A
(F)	Rectangular Partition (Medium, Model 3081)	1	3081-23B
(G)	Rectangular Partition (Tall, Model 3081)	1	3081-23C
(H)	Triangular Partition (Model 3079)	3	3079-24
(I)	Triangular Partition (Model 3081)	4	3081-24
(J)	Open Channel	2 (3079) 3 (3081)	3051-64
(K)	Closed Channel	3 (3079) 4 (3081)	3051-63
(L)	Rubber Foot	4	9631

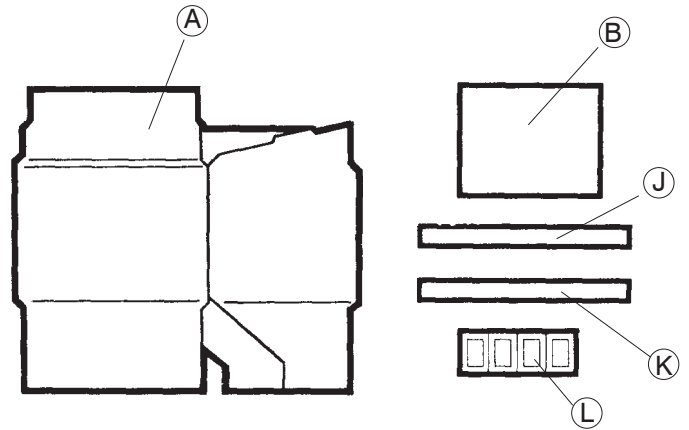

ASSEMBLED UNIT
Model 3079
(12 Openings)

ASSEMBLED UNIT
Model 3081
(20 Openings)

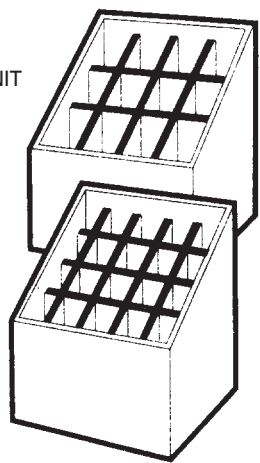

PARTS USED ON
MODEL 3079 ONLY

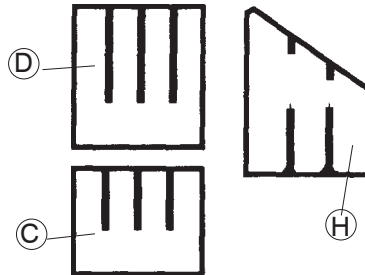

PARTS USED ON
MODEL 3081 ONLY

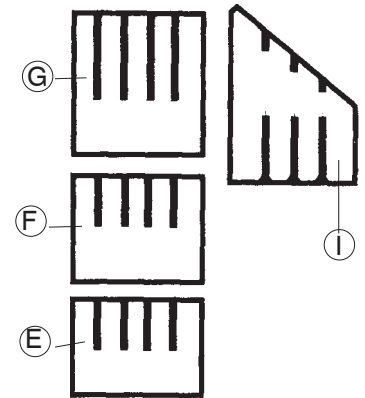

- 1 Square up the (A) Shell, with numbered flaps facing up. Fold in flaps 1, 2, 3 and 4, in that order. Push down on flap 4 until it locks under flap 1.

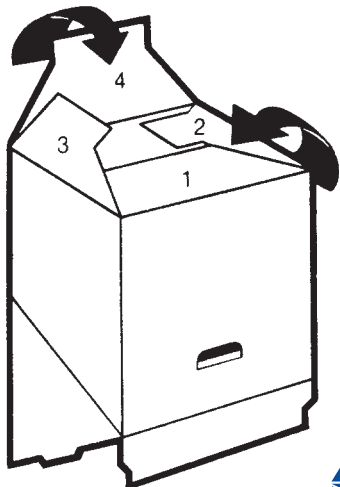

- 2 Turn the shell upright. Now fold in flaps 5 and 6; then fold in flaps 7 and 8 to lock 5 and 6 into place.

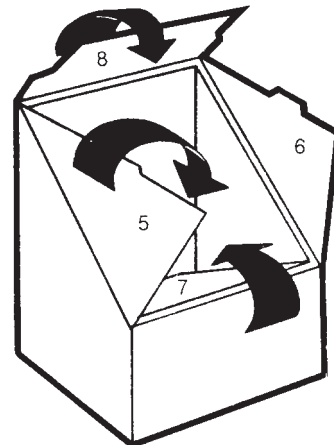

3 Push the (B) Pad into the bottom of the shell.

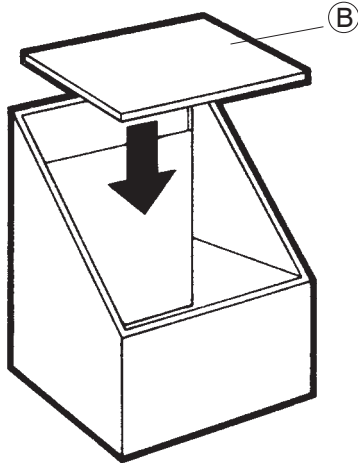

4 Place the Rectangular Partitions ((C) and (D) for Model 3079; (E), (F) and (G) for Model 3081) in order by height. Push the Triangular Partitions ((H) for Model 3079; (I) for Model 3081) down into the slots until the "locking cut" is fully seated and the partition bottoms are even.

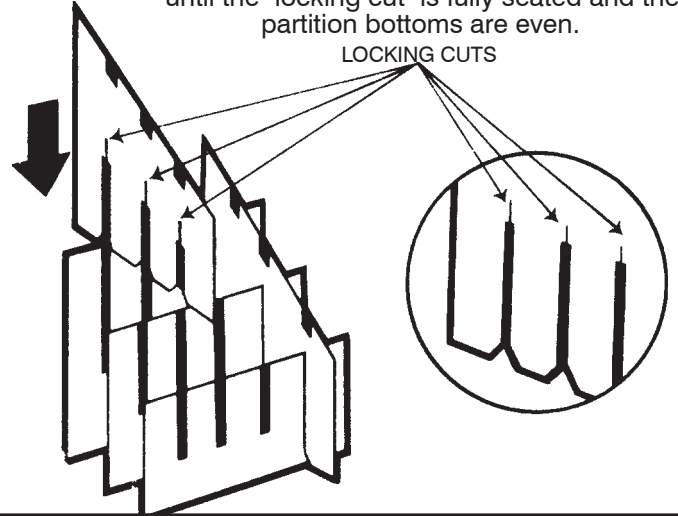

5 Slide the (J) Open Channels over the RECTANGULAR partitions; then slide the (K) Closed Channels over the triangular partitions.

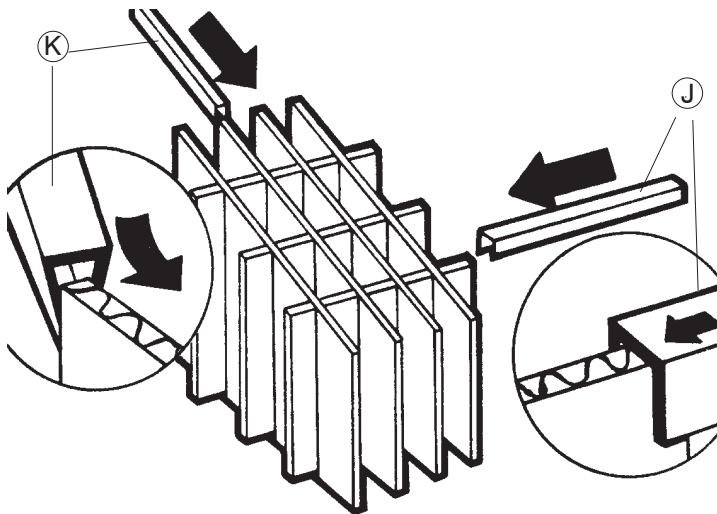

6 Place the assembled divider into the shell.

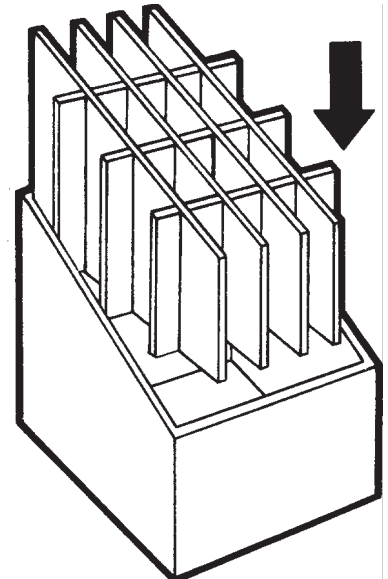

7 Remove the backing material from the (L) Rubber Feet, and place them on the printed squares; press firmly.

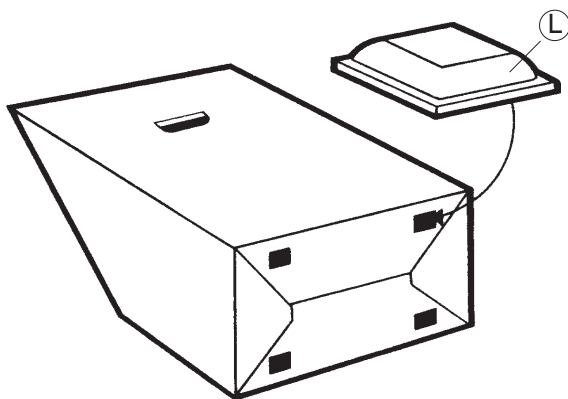

8 Completed Upright Roll File.

