

Retractable Shelving Systems Assembly Guide

SMS-08-V02-S3



STEP 1 Set Up

At the location where the system is to be installed, set all the bases in place and lean the bases on their back edge so the under-side bottom frame is exposed. (Use a protective layer such as cardboard between the bases and the wall). Screw 6 leveling feet, found in the hardware box, all the way into each end of the three base cross members.

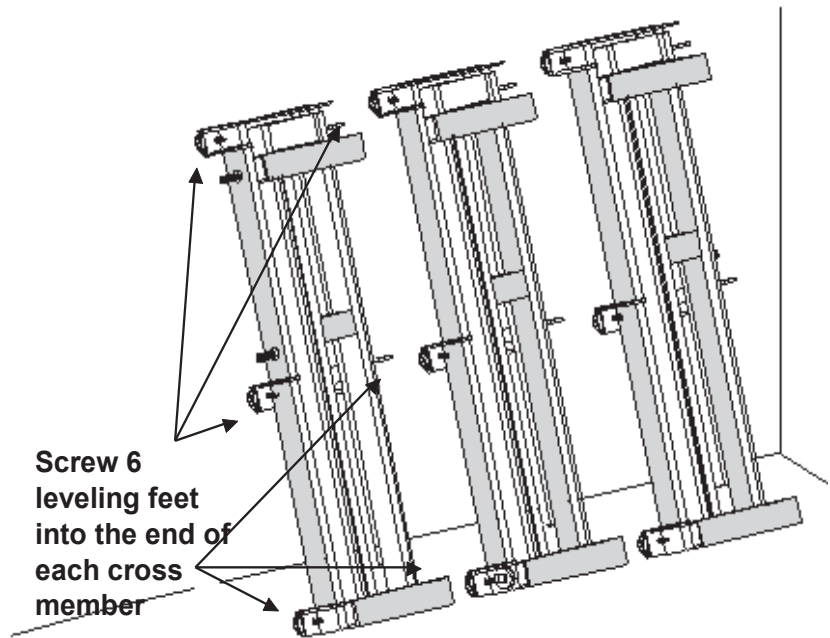

STEP 2 Find High Point in Floor

Using a level, determine the highest point of the floor area where the bases will be placed. The base placed on this highest area will have its adjustable feet screwed almost all the way in when leveled (later). Bases placed elsewhere will have their feet screwed out varying amounts to permit all bases to lie in the same horizontal level plane.

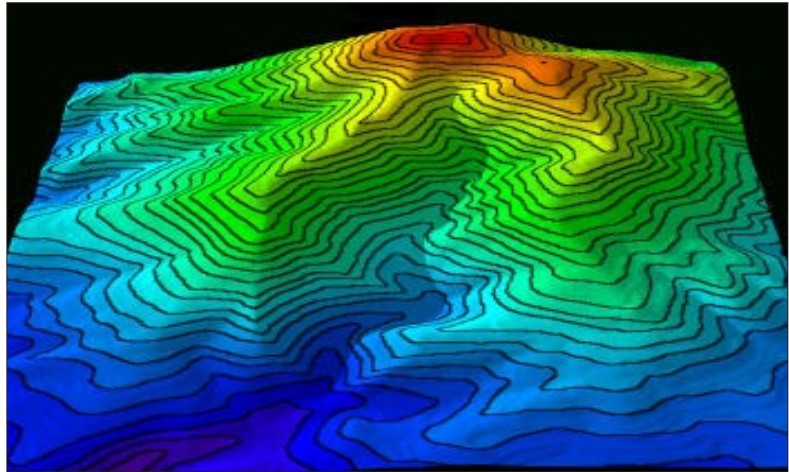

STEP 3 Level the First Base Unit

Select the base lying on the high point of the floor. Set it down a minimum of 1" off the back wall.

Turn feet A and B downward slightly making sure foot C is fully in.

Using a two or four foot level, setting on the top frame sides, level the carriage front to back; adjusting feet A and B as required.

Using a torpedo level setting on top of the shelf frame make sure the carriage is level left to right. Make sure all four feet are firmly touching the floor by rocking the carriage on all four corners.

When leveled, adjust the middle feet "C" down to the floor. Take your time with this unit as it will become your benchmark for the rest of the system.

It is a good idea to finish with the leveling feet down about 25% as this will allow for adjoining bases to be leveled with the surrounding lower floor.

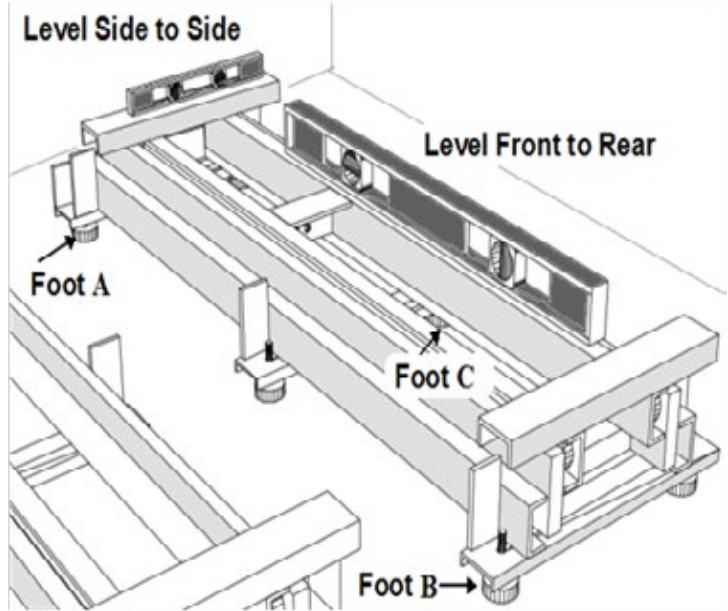

STEP 4 Level All Bases

With a torpedo level and a two or four foot level, begin leveling the remaining bases to be the same elevation and level to the benchmark base. Again, the bases are designed to "butt against" each other. Continue this until all bases have been leveled. Once the bases are all level with each other, and lined up in front, you can begin anchoring.

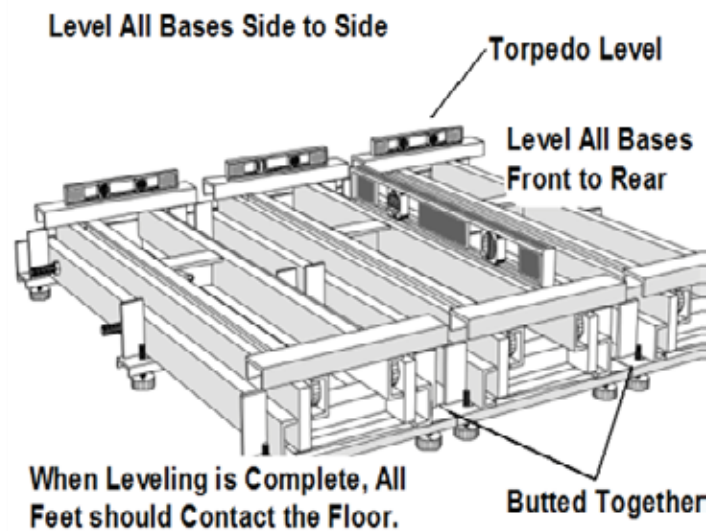

STEP 5 Install Anchor Brackets on End Carriages

Anchoring is done by means of a floor anchoring angle. Begin at the far left or right end base. Attach a slotted anchoring angle next to the vertical plate with a hole next to each adjustable foot. Install a bolt, through the foot bracket and through the anchoring bracket. Make sure the angle bracket is all the way down against the floor. Install a washer and nut and **Hand tighten only**. Repeat this step at the other outside foot bracket location.

Repeat this step on the opposite end base.

STEP 6 Install Pinch Plate Brackets

The middle bases are fastened to the floor using pinch plate brackets. The pinch plate bracket consists of a plate with one hole; an angle bracket with two anchoring holes and one pinch bolt hole; one pinch bolt, nut and washer; and one floor anchor stud with washer and nut. These are used for anchoring in between the bases. They are attached to the middle and back flanges by pinching the plate and angle using the nuts and bolts. The angle is attached to the floor to anchor the bases. **Note:** Only one floor anchor and either hole in the anchor bracket need be used. The second hole is available if something goes wrong.

Loosely assemble the pinch plates and slide these as-semblies over all of the middle and back anchoring flanges on the middle units. Hand tighten the pinch plate bolts while ensuring the angle bracket remains flat in con-tact with the floor.

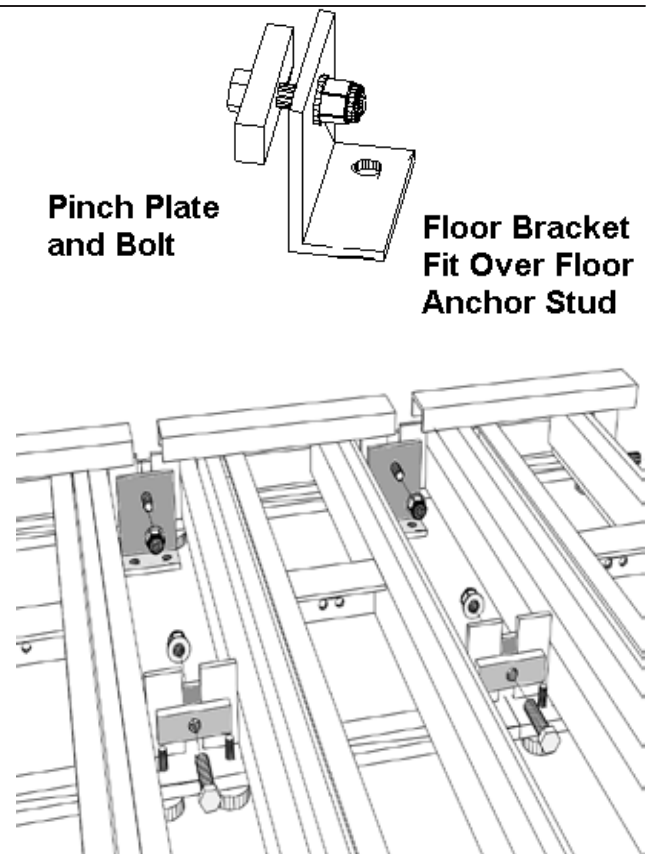

STEP 7 Anchor Angles to Floor

Push all slide units back in to ensure unit sits solidly on the floor.

Begin now to anchor all the angle brackets to the floor, using the masonry bit and concrete anchors provided. Drill through the holes in the angle brackets. Use care to not shift the angles or bases during the drilling process. Vacuum the debris out of the holes before inserting the floor anchor.

Insert the floor anchor stud and securely seat. Make sure every floor angle is anchored securely by at least one concrete anchor stud.

Once this is done **go back and securely tighten all the pinch plates that were previously only hand tight-ened.**

Caution! The drill bit may grab a carpet and pull a run extending out from the base. Use a circle punch or knife to cut carpet prior to drilling anchor hole.

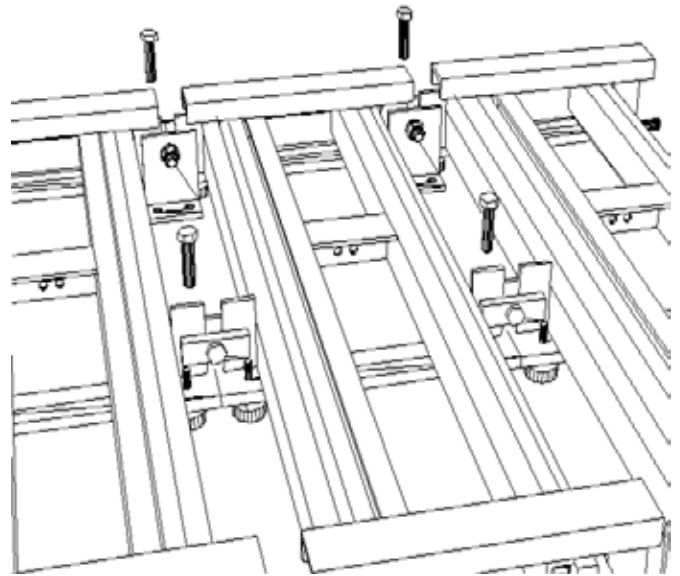

STEP 8 Attach the Shelf Unit

...ALL 4 POST SHELVING UNITS MUST HAVE A SOLID BACK PANEL and SINGLE-RIVET BOTTOM RAILS....

Set the first shelf unit onto the first base. Using a level, make sure the shelf unit stands up vertically on all sides, top to bottom. If necessary, place a shim at the corners to tip the shelf unit slightly to stand vertical. Gently pull out the UltraStor base to full extension. (This allows the drill chips to fall to the floor and not into the track).

At each corner of the shelf, drill the correct diameter tap-ping hole down through the shelf unit into the end of the base cross member. Attach the shelf support using self tapping screws and washers.

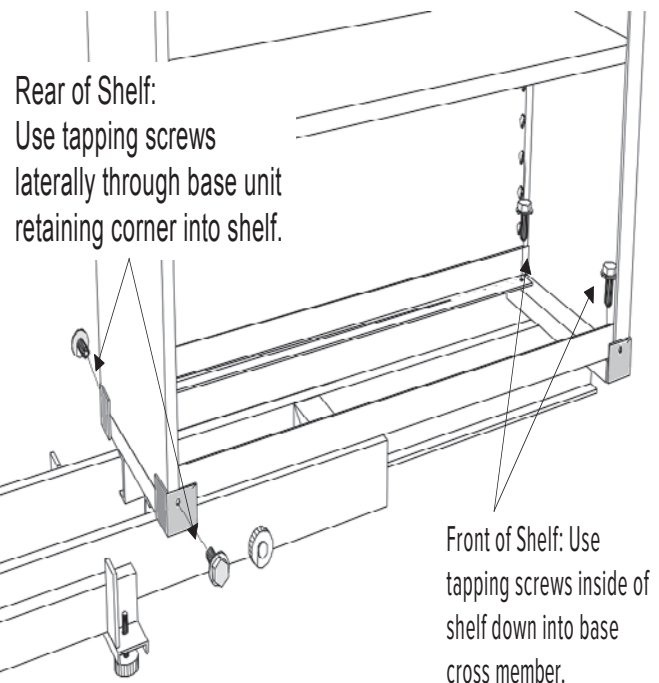

*******See step 13 at this point**



STEP 9

Mount Remaining Shelf Units

Build and set in place the second shelf unit. Before anchoring this unit, be sure it is setting parallel to the first unit on the side and on the front face. If it is not setting parallel, place shims (thin large diameter fender washers) under one or more corners to bring it into parallel.

DO NOT RE-LEVEL THE BASES IN AN EFFORT TO BRING THE SHELF UNIT INTO PARALLEL.

It is very important that all shelf units are exactly parallel to adjacent units to prevent rubbing when they are pulled out. Continue mounting all shelf units in this manner.

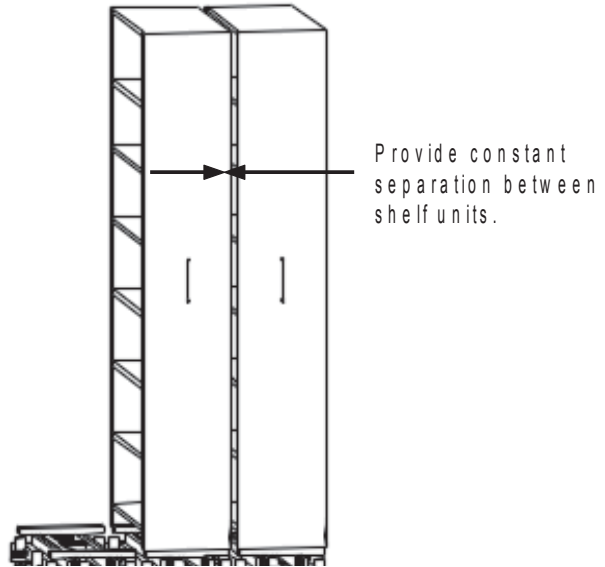

STEP 10

Attach End Panels

Once all shelf units are plumb and anchored you can begin installing the End Panels. If your system has C-Channels or spacers for the back of the End Panel you will need to install them now. Please refer to specific instructions on C-Channel installation. The End Panels are slightly over-sized from the shelving approximately 1". So you will need to adjust the End Panel so that it overhangs the shelving on each side by 1/2"

Also, each End Panel has a dado cut out of the back side. These dados sit over the top of the shelf retaining lip on the carriage and allow the End Panel to secure tightly to the front of the shelf unit. Before installing the End Panel, pre-drill (3) 1/4 holes along the right and left vertical edges of each shelf unit. These holes should be drilled, just below the top shelf, just above the bottom shelf and at the midway point. Set the End Panel over the shelf retaining lip and let it the top of the dado rest on the top of the retaining lip. However you must hold it in place. With a level make sure the End Panel is plumb top to bottom. Then while holding it securely in place roll the entire unit out far enough to have a second installer attach the End Panel from inside the shelving with a drill and the provided screws.



STEP 11 Attach Handles

Once all the End panels are properly installed, determine the correct handle height. It is a good idea to make a cardboard template of the handle hole dimension to insure that inspect to confirm that none of the holes will interfere with a shelf. Stretch a string taut across the front of all units, such that it passes across a handle hole. Ensure that the string is the same distance above the floor at all points. Mark a pencil point thru the template hole centers. Use the template to mark pencil points on all remaining units. The pencil points should all lie under the taut string and such that the handle will be centered on the end face left to right.

Lightly center punch each hole marking while an assistant holds a wood block backing on the inside of the file to prevent damage to the file. Drill $\frac{1}{4}$ inch diameter holes through the file at the center punched locations.

Handles are attached to the shelf unit using a $\frac{1}{4}$ inch bolt inserted from the inside of the shelf unit, through a handle support. **Never attach a handle without a support.** Handles, supports, and screws are in the hardware box.

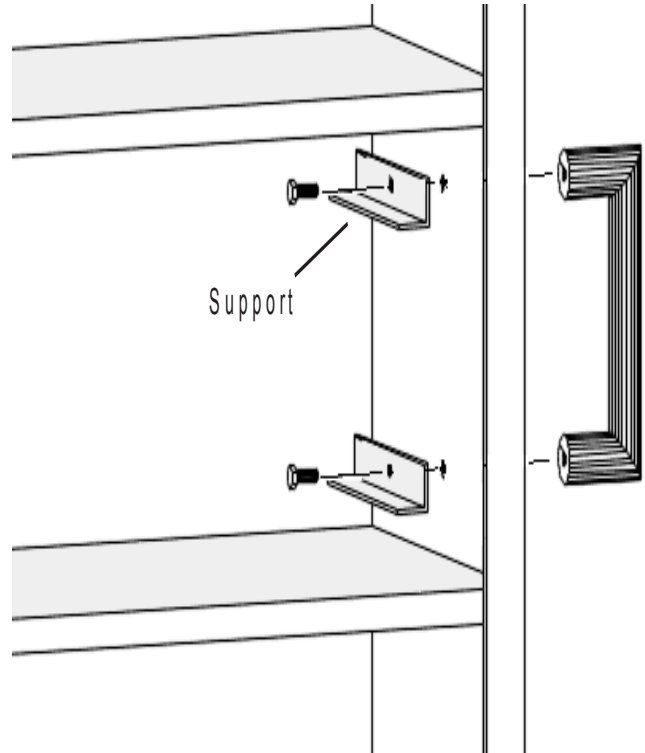

STEP 12 Attach Cover Plates

An End Cover Plate is attached to each shelf unit with self tapping screws through the pre drilled holes in the sides of the top frame corner supports.

The two End Shelf Units will also have a Side Cover Plate installed on the outer side of each end shelf unit, on top of the end cover plate.

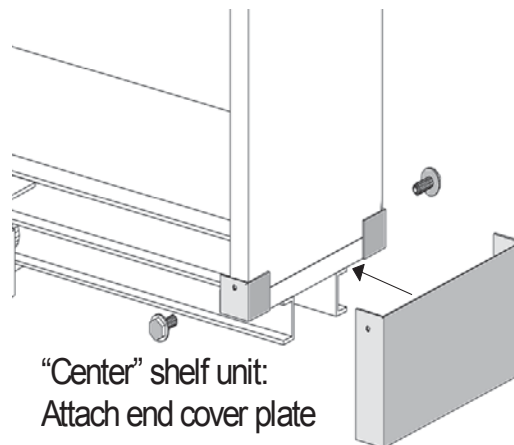

STEP 13 Attach Top Guides

Once all the End panels are properly installed you can install the Top Guides. Top Guides consist of two pieces. One is a “stud” piece that attaches to the open and closed side of each shelf and a “slotted” piece that fits over the top of the “stud” piece and adjusts in and out.

With the provided screws attach a “stud” piece to the open and closed side of each shelf unit. These should sit tight to the back of each End Panel and hang off the back of each shelf by 2.5”. Once these are in place attach a “slotted” piece to each “stud” piece by means of a 1/4” nut and washer provided in the hardware box.

When the Top Guides are installed properly they will **SLIGHTLY** touch the adjacent Top Guide and slide in and out between End Panels. If a Top Guide is too tight to an adjacent Top Guide it tend to Pull out the adjacent Shelf Unit. If this is the case loosen the 1/4 nut and slightly move it away from the other Top Guide.

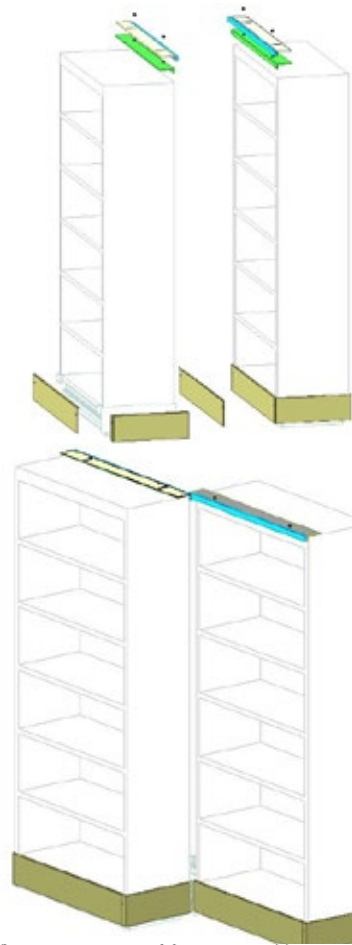

STEP 14 Attach Side Trim

Attach Side trim to the carriages with the hardware provided. If you can't get behind the system you will need to do this step before you install the shelving on top of the carriages.

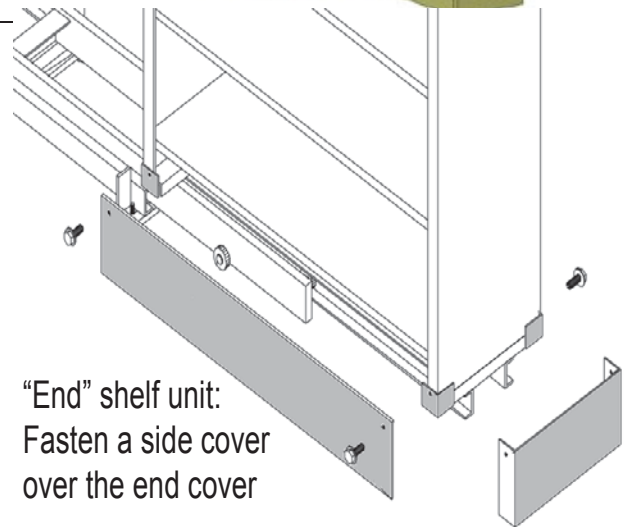

“End” shelf unit:
Fasten a side cover
over the end cover

