

Mobile File Storage Assembly Guide

SMS-08-V25-B

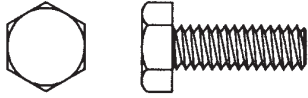



1/4-20 x 3/4"
Hex Head Bolt



1/4-20 Flanged
Hex Nut

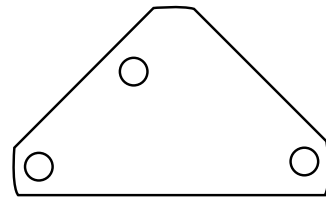

Gusset

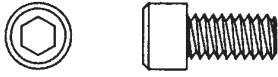

1/4-20 x 1/2"
Allen Cap
Screw



1/4-20 Nylock Nut

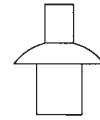

Rivet

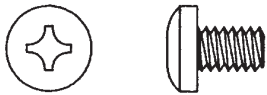

1/4-20 x 3/8" Pan
Head Phillips
Machine Screw

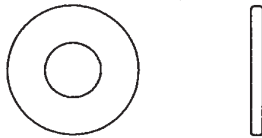

1/4 USS Flat Washer

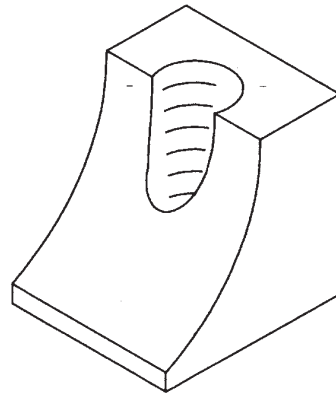

Wheel End Stop



#8 x 3/8"
Tek Screw
Phillips

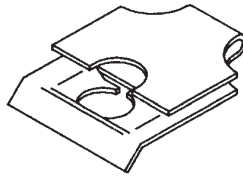

1/4-20 "J" Type
Tinnerman Nut

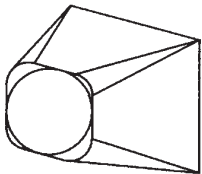

3/4" SQ x 1/2" High
Black Self Adhesive
Rubber Bumper

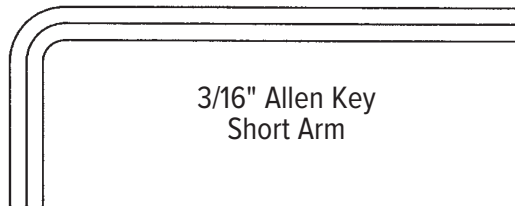

3/16" Allen Key
Short Arm

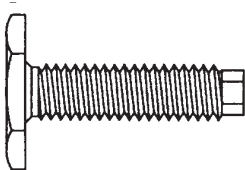

3/4" Hex x 5/16-18 x 1 1/4" Max
Hex Stem/Base Glide

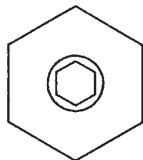

NOTE: All Hardware shown actual size.



PARTS LIST

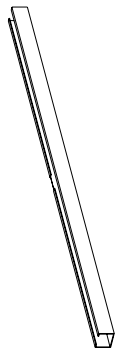

Top Stabilizer Channel
A11858-36

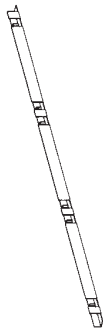

Connector Channel
B11810-36

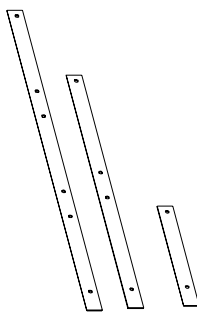

End Cap
B11798

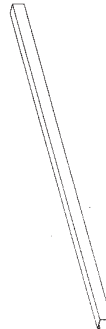

Stainless Steel Front Cap
B11811-36



Safety Stop
A11891



Conversion Plate
B11808

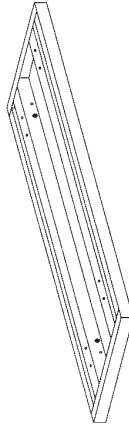

Carriage Assembly
D11885

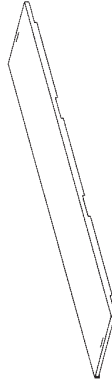

Deckin
B11812

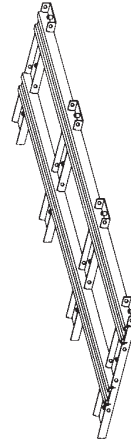

Rail Assembly
D11884

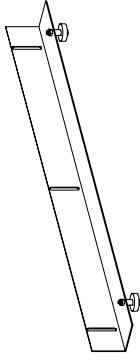

One Piece Bi-Slide Roller Bracket
B12764

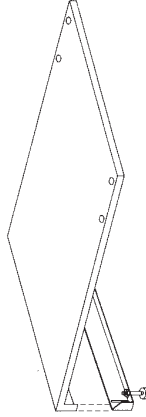

Tri-Slider Top Stabilizer
Bracket Assembly
TSRB

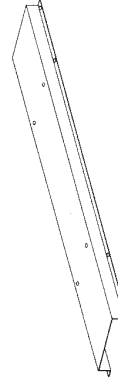

Tri-Slider Hat Channel
TSHC



NOTE: All shelving used on a Bi/Tri Slider system must have the same overall height. The shelving must also have a minimum of 1-1/2" of clearance from the floor to the filing surface of the bottom shelf.

TOOLS REQUIRED: 7/16" wrench & socket set

- 7/32" socket
- small flat blade screwdriver phillips
- screwdriver
- 5/16" drill bit
- screw gun
- 4 foot bubble level
- water level, laser level or transit
- hammer

STEP 1: Assemble the rear stationary shelving sections according to the manufacturer's instructions and position on the floor. Be sure to level this row before moving on to the next assembly step. When using stackable shelving you must use 2" bases with built-in leveling guides and 1" tops. It is recommended that stationary sections be secured to wall.

STEP 2: Attach the top stabilizer channels to the tops of the stationary sections. Position each channel flush with the front and even with the sides of each of the top section (Holes are pre-punched in the 1" high top when using Stackable Shelving.) Attach the channel using three 1/4-20 X 3/4" bolts and flange nuts. Repeat for each rear stationary section. **(See figure 1.)**

STEP 2A: *FOR TRI/QUAD SLIDER SYSTEM ONLY.* Follow directions in step 2; however, attach additional top stabilizer channels directly in back of the first row using three 1/4-20 x 3/4" bolts and flange nuts. (As described in step 2, holes are pre-punched for Bi and Tri-Slider hat channels only when using 1" high tops.) Repeat for each rear stationary section.

NOTE: For Quad-Slider systems it will be necessary to pre-drill tops for attachment of top stabilizer channel.



FIGURE 1

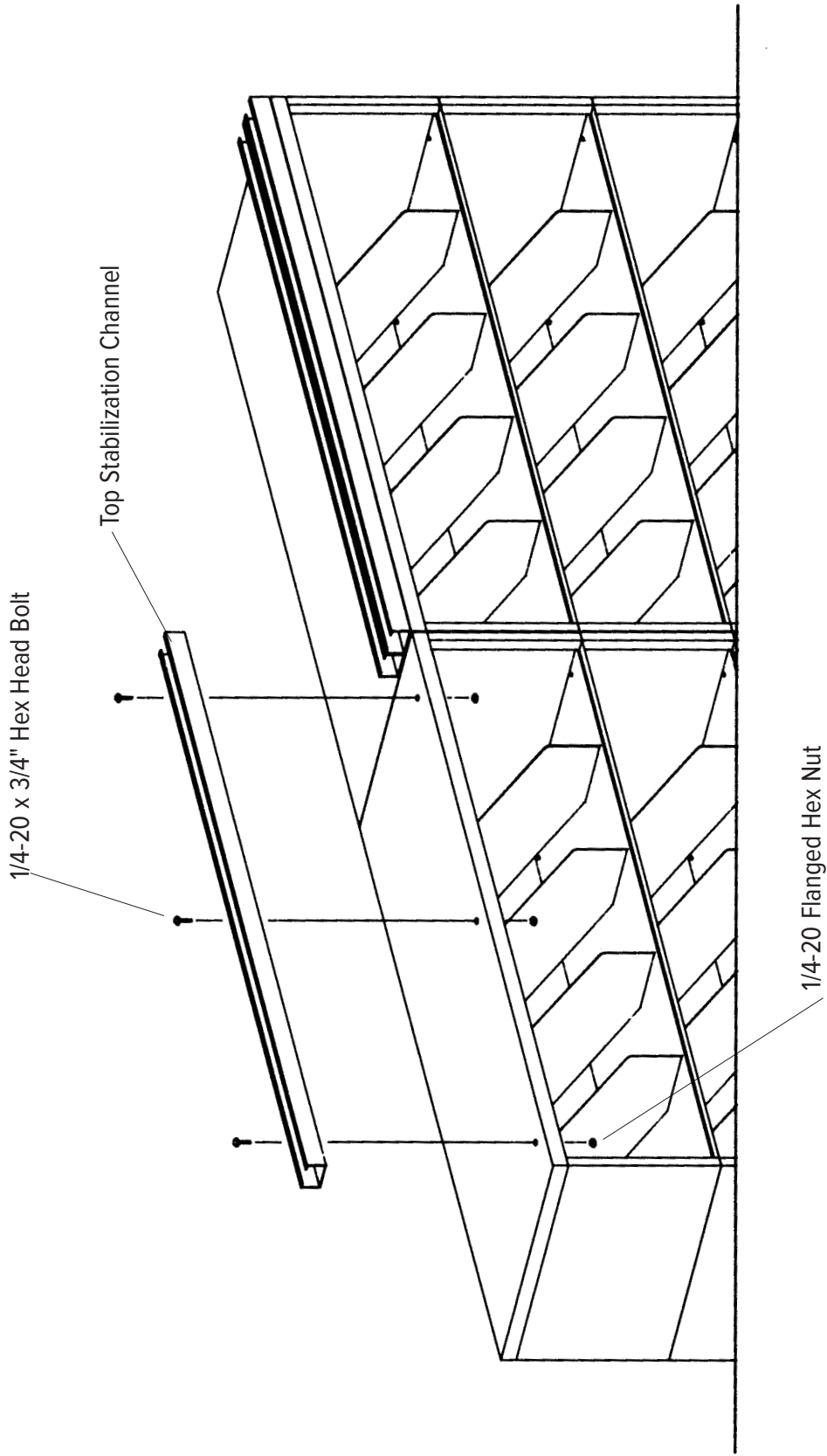

NOTE: All systems will consist of one starter rail assembly and the required amount of add-on rail assemblies.

Example: A B632LT consists of (1) #36LTBSST; starter and (2) 36LTBSAO; add-on (Part numbers are found on each box.) The starter rail assembly contains one section of rail and hardware. The add-on rail assembly contains one section of rail, hardware and one mobile carriage.

All mobile carriages are preset at the factory to include 2" of overtravel. Systems up to a 4/3 configuration for Bi/Tri/Quad do not require overtravel. Overtravel can be increased or decreased as needed, please refer to the diagram below for more information.

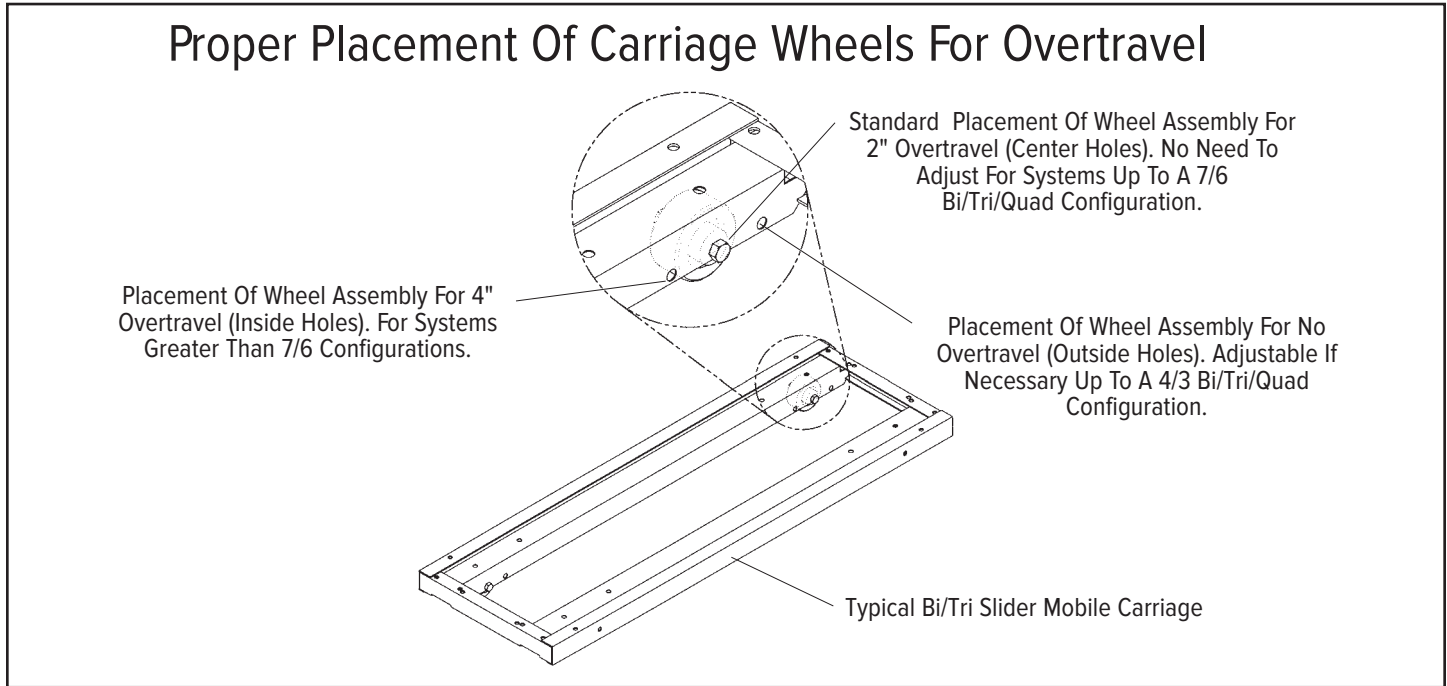

STEP 3: Install 12 leveling glides per rail section making sure that each one is screwed in and flush with the bottom of the rail assembly.

STEP 4: Position stationary connector channels on the front bottom of each stationary base. Attach each connector channel using a minimum of (4) #8 x 3/8" tek screws (**See figure 2, detail A**).

STEP 5: Join rail assemblies together using (4) 1/4-20 X 3/4" bolts and flange nuts. Rail sections will have corresponding holes for attaching side to side (**See figure 2, detail B2**). Position rail assembly on floor, do not attach to connector channel at this time.

STEP 6: Attach the deck end cap to the rail section starting from the left end of the rail assembly using (2) 1/4"-20 X 3/4" bolts and flange nuts (**See figure 2; details B1, B3**). Repeat procedure for right side of system.

STEP 6A: FOR TRI/QUAD SLIDER SYSTEMS ONLY. Position additional row(s) of rail sections in front of Bi-Slider rail sections described above. Attach deck end cap to Bi-Slider and Tri-Slider track assembly using (4) 1/4-20 X 3/4" bolts and flange nuts. Repeat procedure for right side of system.

STEP 7: Attach the assembled rail section to the connector channel. The rail assembly will have corresponding slots which will secure to the connector channel. (**See figure 2**).



FIGURE 2

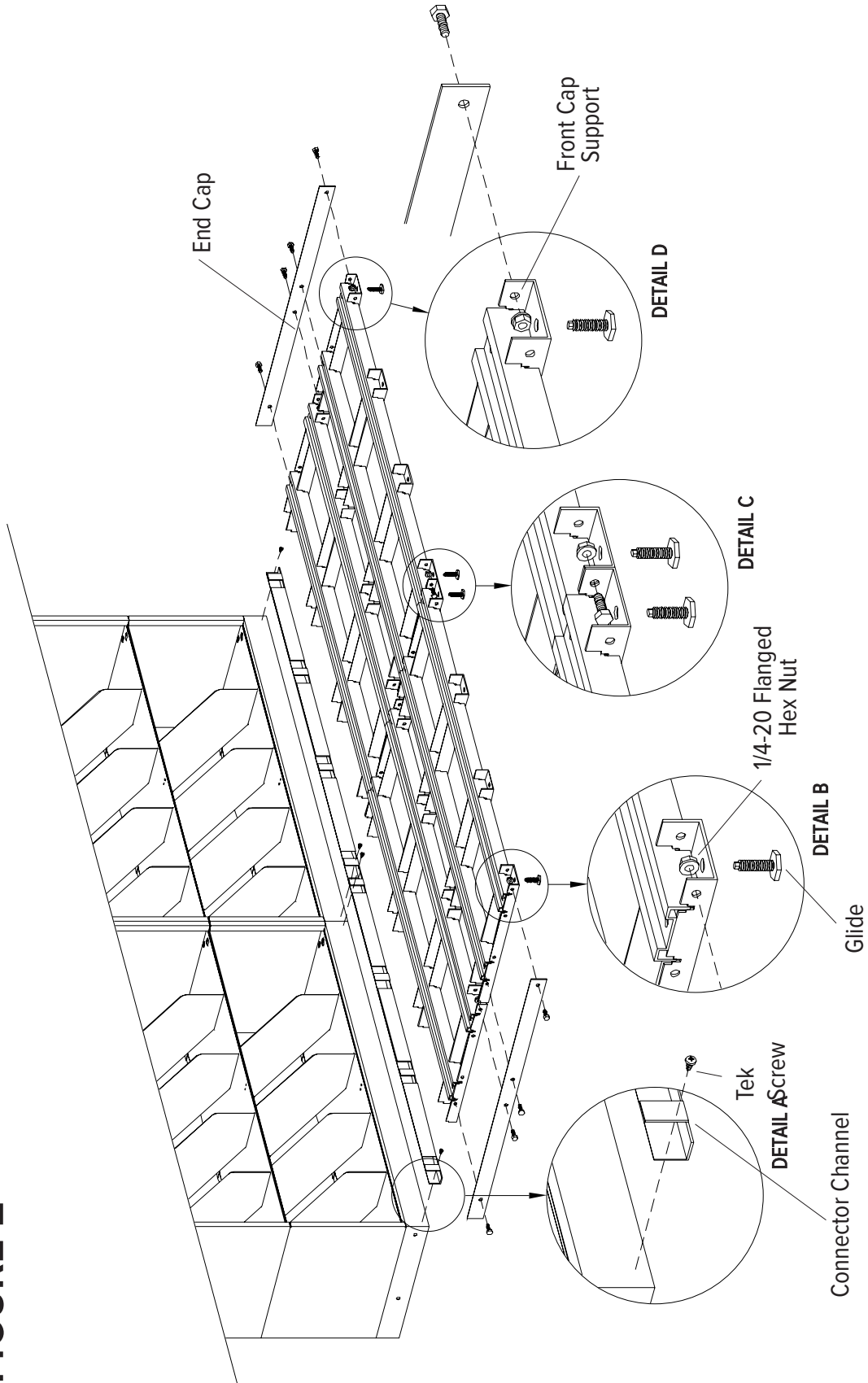

STEP 8: LEVELING: Determine highest point on the rail assembly. Working out from this point, level the rail by adjusting the leveling glides. **IMPORTANT!** For system to function properly all rails must be level from left-to-right, front-to-back, and rail to rail. All leveling glides must be in contact with the floor.

STEP 9: Install decking. Deck sections interlock with the rail assembly and should be flush with the top of the rails when installed. (See figure 3).

STEP 9A: TRI/QUAD SLIDER SYSTEMS ONLY. Install additional sections of decking which span between two rail assemblies (See figure 3).

STEP 10: Attach stainless steel front cap to each rail section by snapping over front rail cross-members (See figure 3, Detail C). Repeat for remaining rail sections.

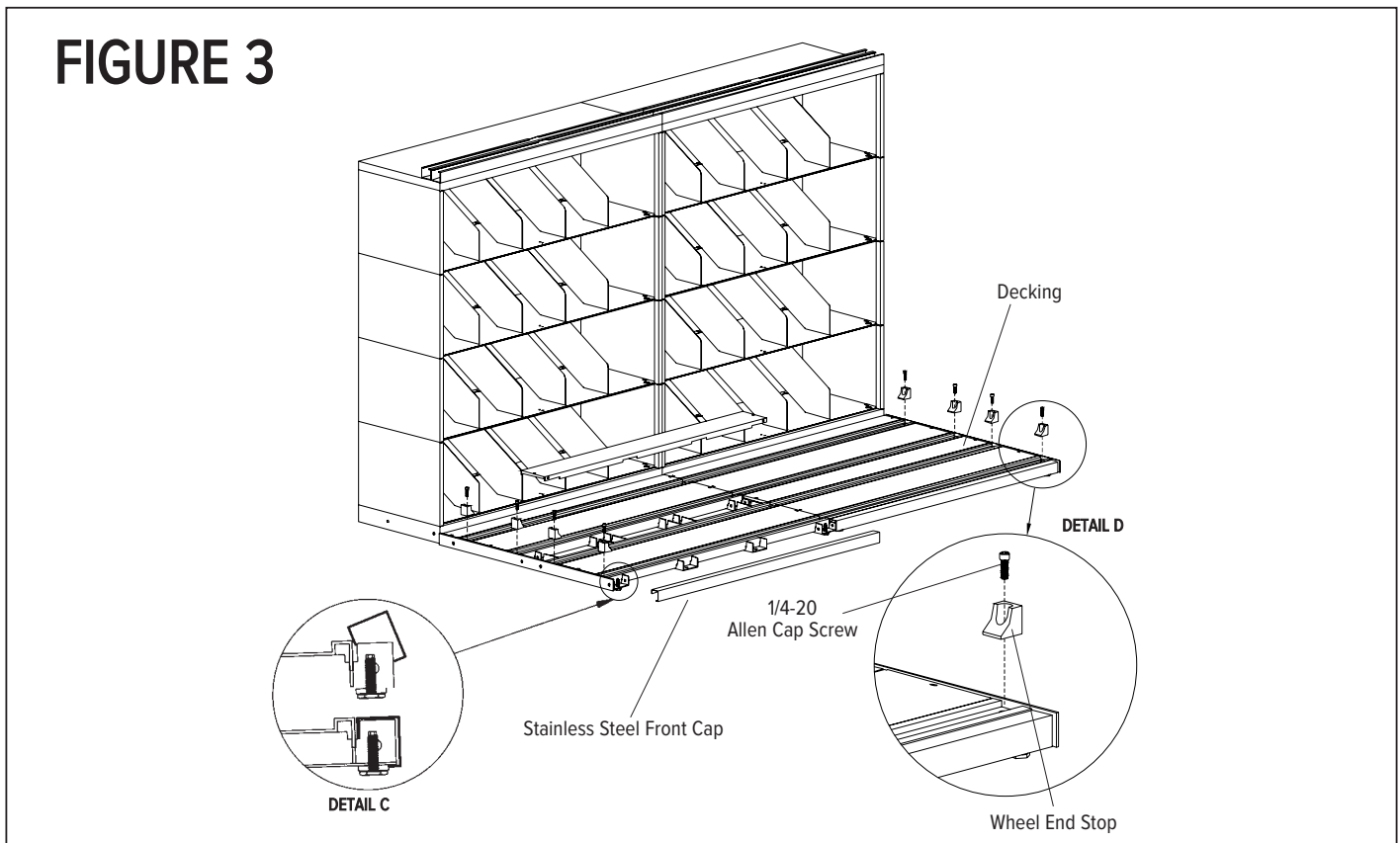

STEP 11: Attach 2" bases to mobile carriage using (4) 1/4-20 x 3/4" hex bolt and 1/4-20 nylock nut (See figure 4). NOTE: When using 2" bases, the carriages and bases will have pre-punched holes for attachment.

STEP 11A: When installing 4-post shelving conversion plates are required to prevent shelves from shifting on carriage (See figure 4). Assemble four-post shelving as per manufacturer's instructions and attach to carriage. NOTE: It is recommended that single rivet shelf supports (Not included) be used for secure attachment to mobile carriage.

STEP 12: Assemble ThinStak Shelving, as per assembly instructions supplied, and attach to 2" base.



Important: Step 12a-12b for Thinkstak Shelving

STEP 12A: Each movable shelf section will require 6 rivets per shelf opening. Please refer to the diagram below for proper rivet placement. Additional rivets are included in each hardware kit.

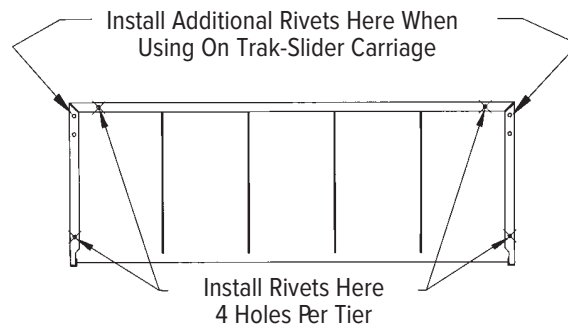

STEP 12B: Note: Gussets are used on moveable shelving units only. Assemble shelving as per shelving instructions. Before securing top cover to top tier, slide a gusset into each rear corner of the top cover and secure with 1/4-20 screws and nuts as shown. Secure remaining screws and nuts as shown in shelving instructions. Repeat steps for all moveable units.

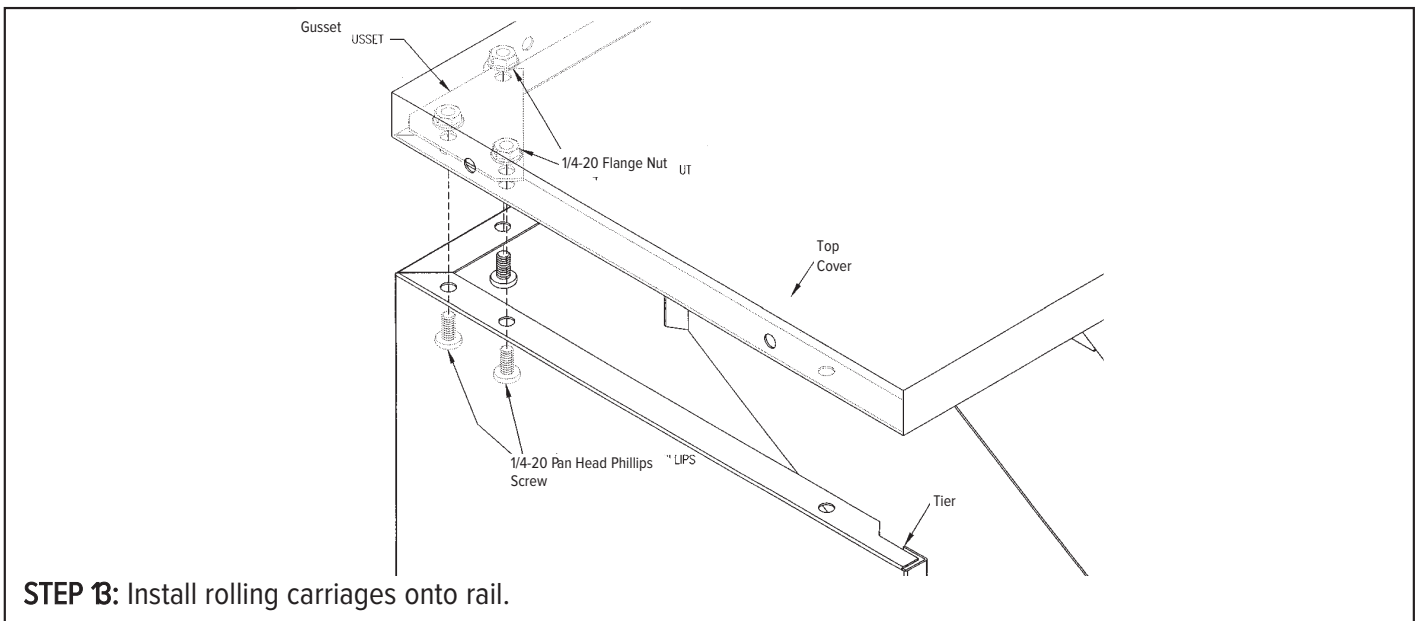
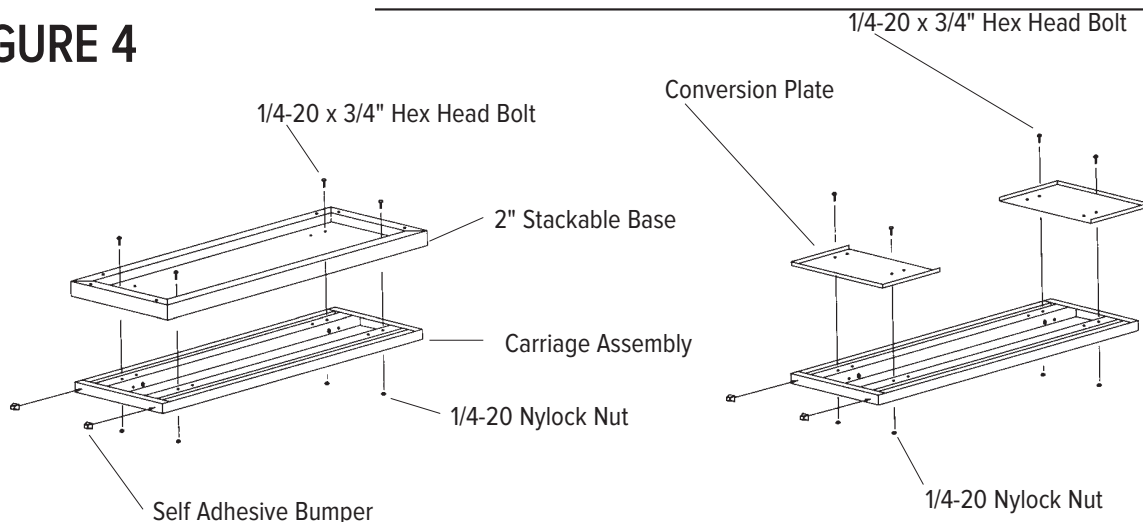

FIGURE 4



STEP 14: Mount a top stabilizer bracket assembly to the top of each Bi-Slider rolling section using (3) 1/4-20 x 3/4" hex bolts, (3) flat washers and (3) 1/4-20 nylock nuts (holes are prepunched when using 1" tops). **See figure 5.**

STEP 14A: Tri/Quad Slider system only. Mount the Tri-Slider hat section to each front rolling section using eight hex 1/4-20 x 3/4" bolts and (8) 1/4-20 nylock nuts. Attach Tri-Slider top stabilizer bracket to hat channel using (4) hex 1/4-20 bolts (**See figure 5**).

NOTE: If the top roller mount assembly rubs along the stabilizer channel, the roller must be adjusted. Loosen the two bolts which secure the rollers to the roller bracket assemblies. Adjust so that each roller moves freely in the channel. Firmly re-tighten each bolt after adjustment.

STEP 15: After all carriages have been installed, install wheel end stops onto rail using one 1/4"-20 x 1/2" allen cap screw (**See figure 3-detail D**). One pair of end stops are required for each end of system.

STEP 16: Remove (1) 1/4-20 x 3/4" hex head bolt from far left and far right side of top stabilizer channel. Insert over-head safety stop to each end of top stabilizer channel and re-attach using the 1/4-20 x 3/4" nut and bolt (**See figure 6**).

STEP 17: Install 1 pair of black self-adhesive rubber bumpers to each rolling carriage (**See figure 4**). **NOTE:** One pair is needed between two mobile carriages.

FIGURE 5

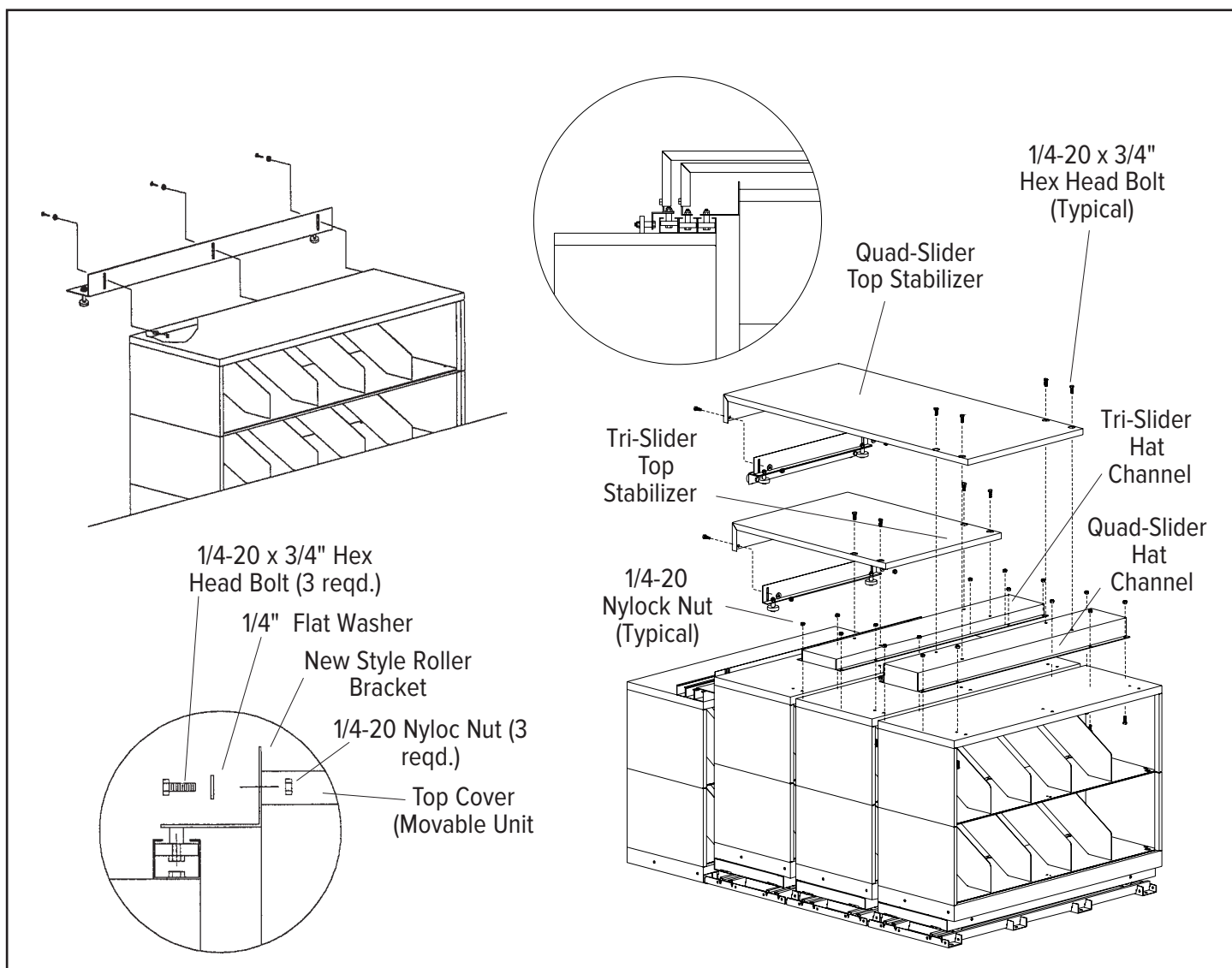
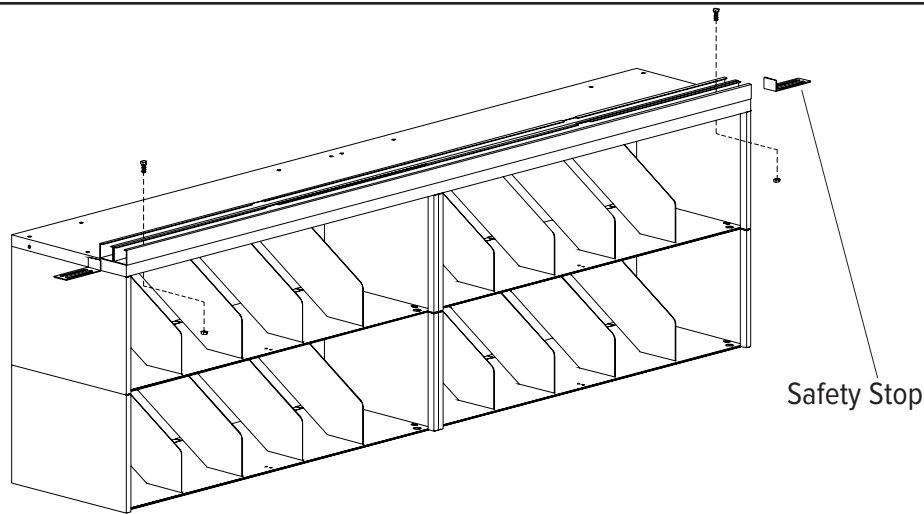

FIGURE 6



SAFETY PRECAUTIONS

- 1) Read through these instructions again insuring that all steps were completed.
- 2) Recheck and tighten any loose bolts or fittings.
- 3) Check to see that all top stabilizer channels are securely fastened to the tops of the stationary sections.
- 4) Check to insure that the end stops are securely fastened to the rail assemblies.
- 5) If attaching stationary section to wall make sure to follow manufacturers recommendations.

LOADING FILES

Loading a Bi/Tri Slider system in the correct manner is very important. It balances the paper weight load throughout the entire system and minimizes the odds of having to move the rolling sections every time the system is accessed. Careful planning of this phase of the installation will make filing and retrieval a lot easier.

It is recommended the system be loaded first from the left rear section followed by the first rolling section on the left side of the Bi-Slider. If a Tri-Slider is installed, next load the first rolling section on the left side of the front row (See figure 7).

Repeat loading from the rear to the front until completed.

FIGURE 7

| | | | | |
|----------|----------|----------|----------|----------|
| 1 | 3 | 5 | 7 | 9 |
| 2 | 4 | 6 | 8 | X |

BI-SLIDER

| | | | | |
|----------|----------|----------|-----------|-----------|
| 1 | 4 | 7 | 10 | 13 |
| 2 | 5 | 8 | 11 | X |
| 3 | 6 | 9 | 12 | X |

TRI-SLIDER

RE-LEVELING THE BI/TRI SLIDER SYSTEM

It rarely occurs; however, after the Bi/Tri Slider system has been loaded, the rolling sections may begin to move or creep on their own. While this problem is more annoying than hazardous, it may be corrected by re-leveling the rail assembly. The Bi/Tri Slider system has been designed so that the deck plates can be easily removed for access to the leveling glides.

To remove the deck plates, move the rolling sections to one side. Then, insert a slotted screw driver into the slot provided on the decking and with even pressure pull the deck plates up and remove.

Next, re-adjust the leveling glides by turning them one-quarter turn at a time either raising or lowering the rail assembly to the desired height to stop the unwanted movement. It is very important that all leveling glides maintain contact with the floor. When this adjustment has been completed, re-install the deck plates.

