

Media Shelving Assembly Guide

SMS-08-V25-VS

TOOLS NEEDED FOR ASSEMBLY: Phillips Screwdriver & Hammer
 HARDWARE INCLUDED:

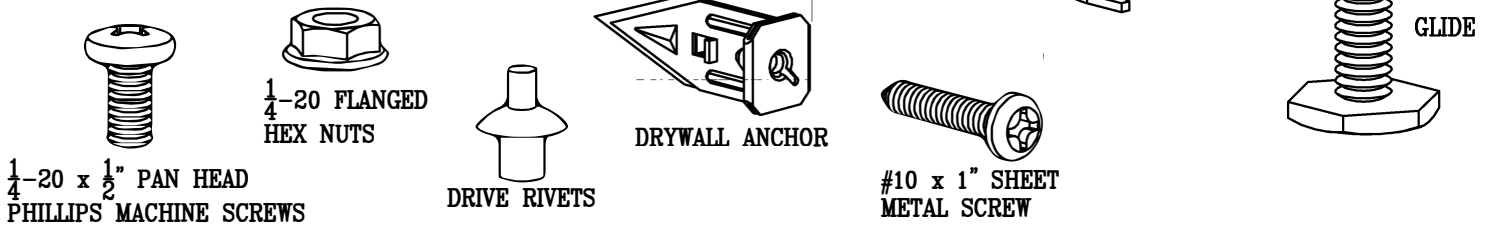

1.) Insert 4 glide clips into the rectangular slots in the bottom of the base (Detail 7). Leveling glides and glide clips are only available on 2" & 4" bases. 1" bases can only be leveled with shims (not included). You will need to use a hammer to fully seat glide clips. Thread glides into each glide clip. Place base unit in position on floor as shown.

2.) Place the first tier on top of base. Slide the tabs on the tier under the flange on the base (Detail 5). Align the holes and install (4) drive rivets (Detail 1), 1 in each outside corner on back, and 1 in side hole closest to the front of the tier (Figure 1). Strike each rivet with hammer until the small steel center of the rivet is flush with the crown portion of the rivet.

Note:
 Postion a piece of cardboard between wall of cabinet and hammer when striking rivet, to prevent surface damage to unit.

3.) Place the second tier on top of the first, sliding the tabs of the top tier under the flange of the lower tier (Detail 5). Align the holes and install (4) drive rivets (Detail 2), 1 in each outside corner on back and 1 in side hole closest to the front of the tier (Figure 1). For Standard Fixed Divider Tiers, see View A. For Movable Plate Divider Tiers, see View B.

4.) Repeat step 2 for each additional tier.

5.) Install top cover by hooking lip on rear of top (Detail 3) under the flange of the top tier. Align the holes on the sides and install (4) 1/4-20 nuts and 1/2" long pan head screws (Detail 4) to secure top cover in place.

6.) If you are installing stacks of tiers, either side-by-side or back-to-back, they must be attached to one another (Figure 2). Align the holes in the top and attach the stacks together using 1/4-20 nuts and 1/2" long pan head screws. Two (2) extra screws are included with the top & base set for this purpose.

7.) When you are installing a single stack of tiers it MUST be attached to a wall. The top cover has holes located in the rear for this purpose (Detail 6). Use the drywall anchor & #10 x 1" screw (supplied) for attaching stack top cover to wall. The following procedure is suggested: With stacks positioned against wall, mark the wall using holes in rear of top cover as a template. Move the unit aside. Place tip of anchor on marked location & tap with hammer until the flange is seated flush against the wall. Position stack unit & insert the #10 x 1" screw through the top cover & into the wall anchor. Turn screw clockwise into anchor until the top cover is securely seated against the wall.

8.) On Standard Fixed Divider Tiers (see View A), dividers are welded in place. On Movable Plate Divider Tiers (see View B), install 1 divider per opening by inserting into channel in bottom of tier.

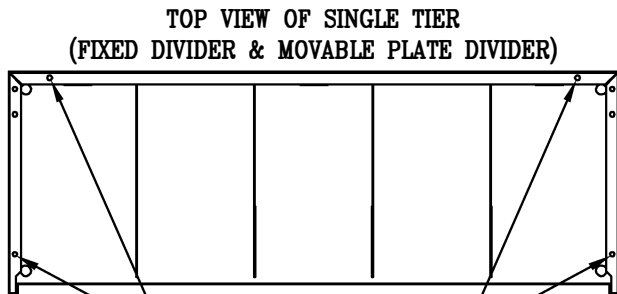

INSTALL RIVETS HERE
 4 HOLES ONLY PER TIER

FIGURE 1

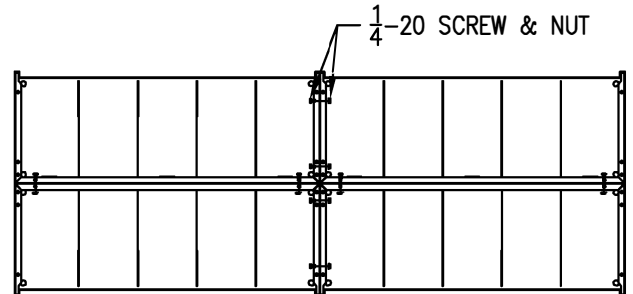

TOP VIEW
 (securing side-by-side & back-to-back)

FIGURE 2



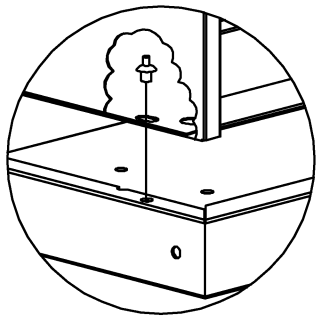

DETAIL 1

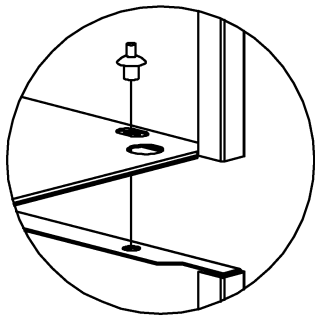

DETAIL 2

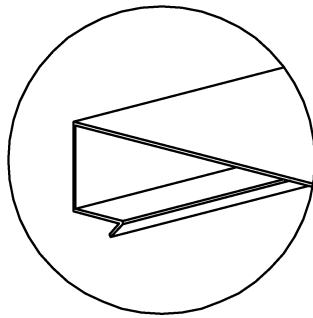

DETAIL 3

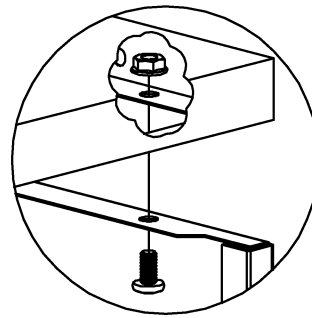

DETAIL 4

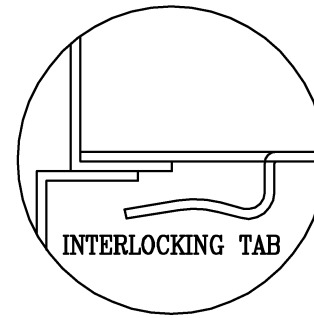

INTERLOCKING TAB

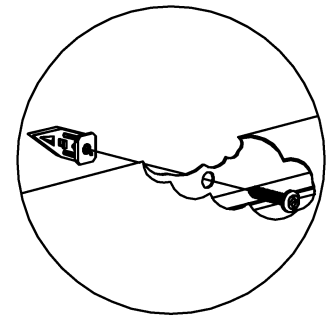

DETAIL 6

TOP COVER

TOP COVER

DETAIL 4

DETAIL 6

DETAIL 6

DETAIL 4

TIER

TIER

DETAIL 2

TIER

TIER

DETAIL 7

DETAIL 2

DETAIL 1

DETAIL 1

BASE

BASE

VIEW A
FIXED DIVIDER TIER

VIEW B
MOVABLE PLATE DIVIDER TIER

