

# Deed Book Roller Shelving Assembly Guide

## SMS-25-RS42

### TOOLS REQUIRED FOR ASSEMBLY

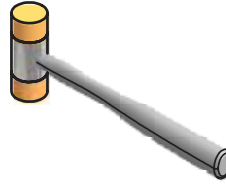
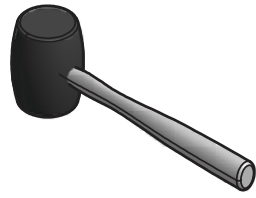

Rubber Mallet or Plastic Tip Hammer

### PARTS REQUIRED FOR SHELVING ASSEMBLY

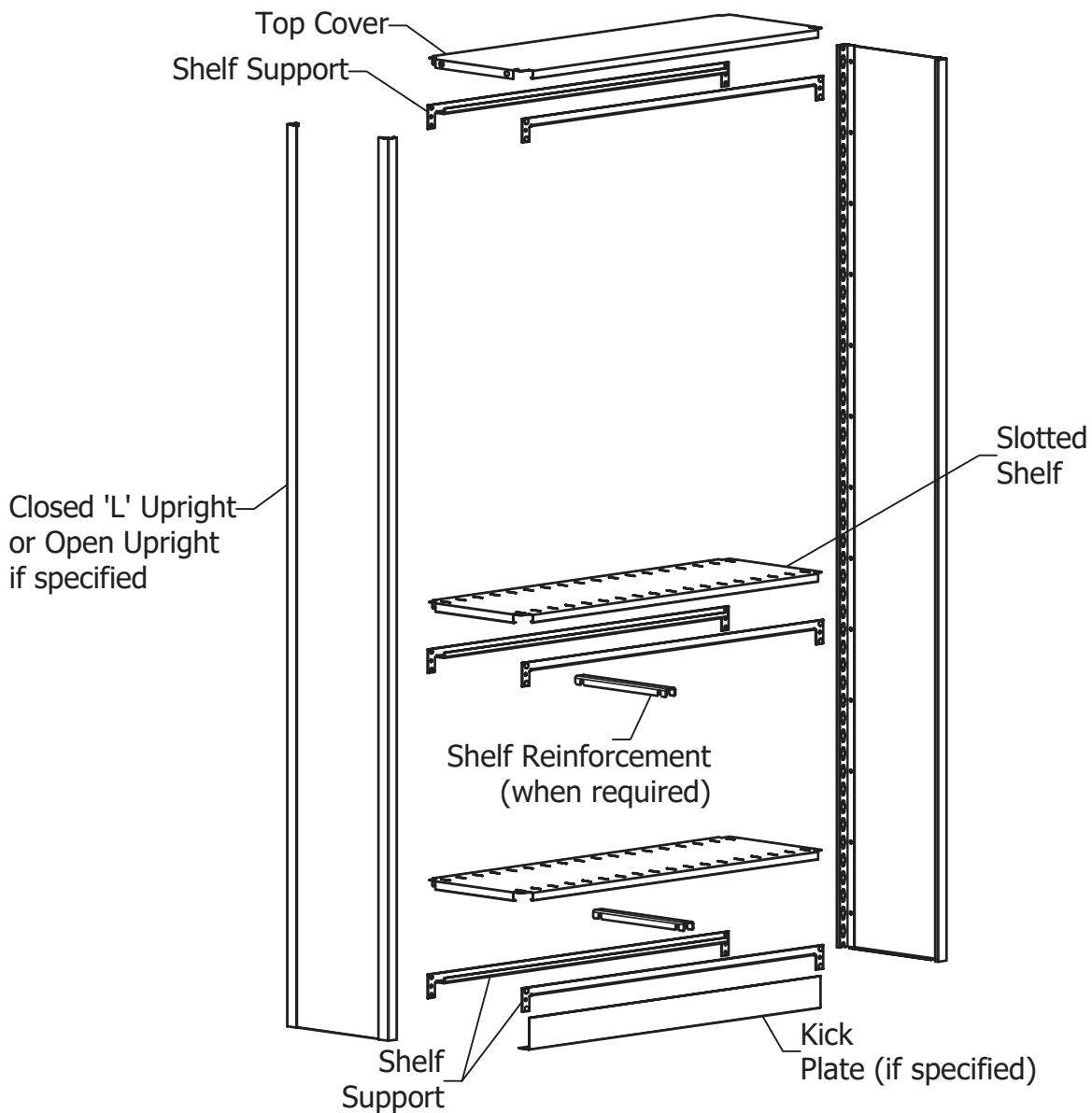

2" Kick Plate  
(Typical Configuration)

*Figure A*

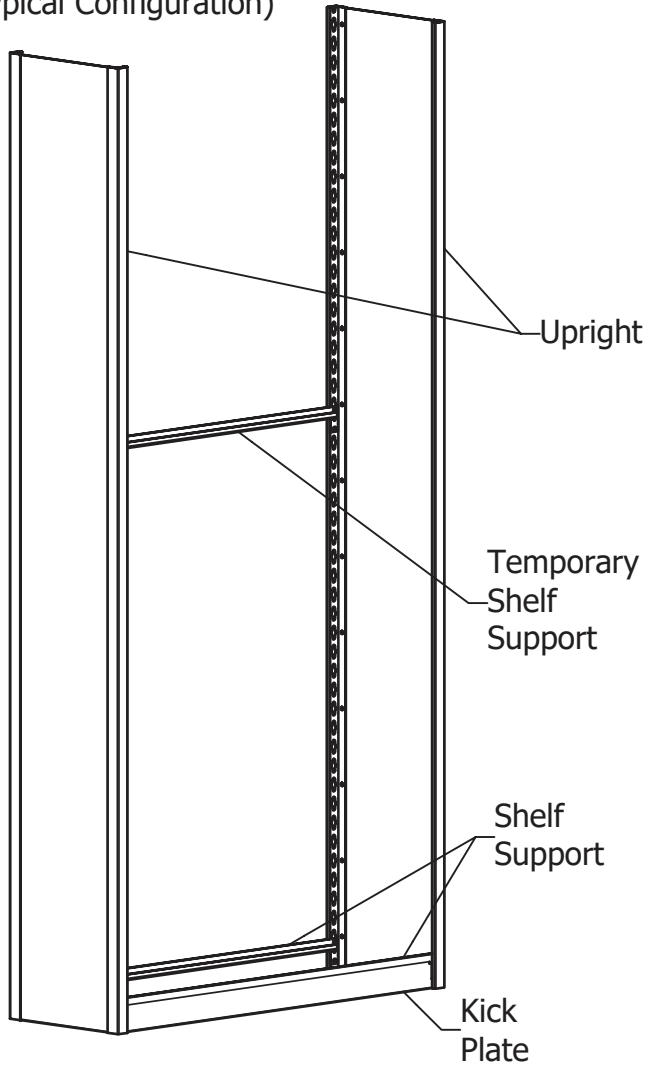

**Step 1:**

Temporarily mount a shelf support at chest height to hold uprights in position (see Figure A). Rivets of shelf support fit into keyholes on uprights. Use a rubber mallet or plastic tip hammer to tap shelf support into bottom of keyholes.

**Step 2:**

Bottom components will be assembled as shown.



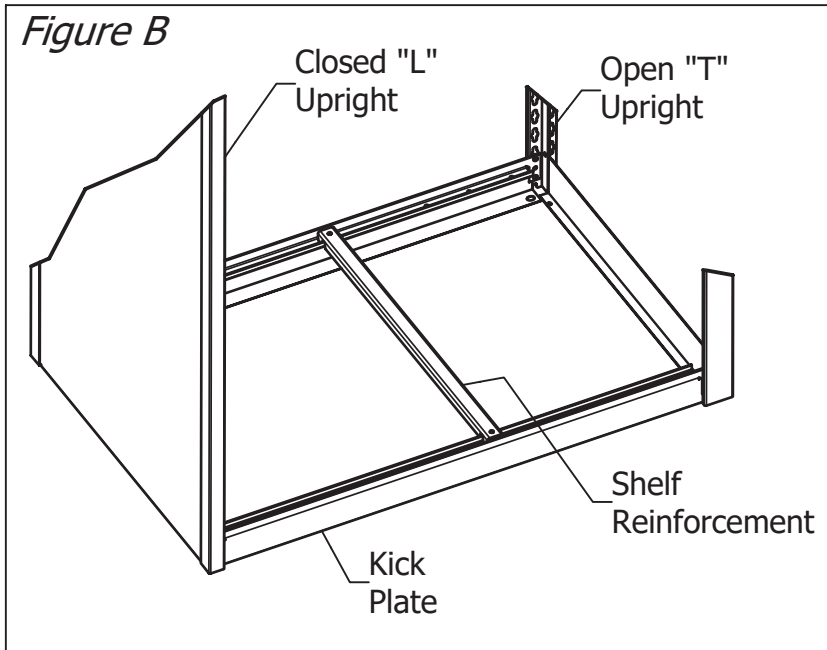

**Step 3:**

Install shelf reinforcements as shown in Figure B. See table for number of reinforcements per shelf.

Typical Shelf Reinforcements	
Depth of Shelving	No. of Reinforcements
12"	None
15"	None
18"	Two
24"	One
30"	Two
36"	Two
up to 36"	Two
42"	Three
48"	Four

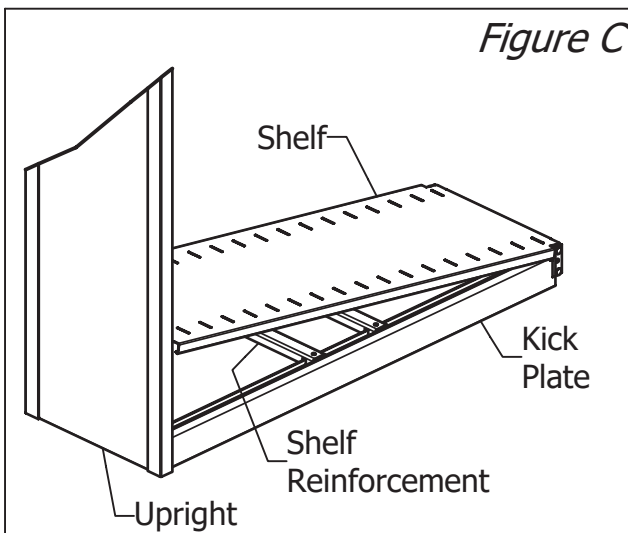

**Step 4:**

Install shelf by tilting as shown in Figure C (kick plate configuration shown). Shelf should then lie flat on shelf support and shelf reinforcement.



Top Cover (shown  
without knockouts)

*Figure D*

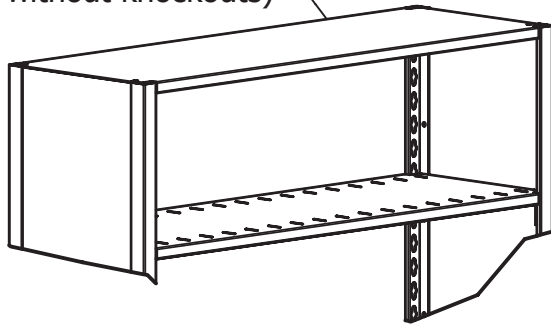

**Step 5:**

Install top cover the same way shelves were installed. Shelf supports for top cover should be positioned in the top two most keyholes.

**Note:**

Top shelf may not require shelf reinforcements.

