

Blueprint Counter Height Shelving Assembly Guide

SMS-08-V25-PD

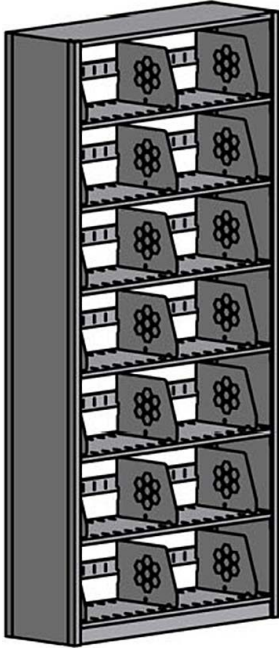

SINGLE ENTRY STARTER

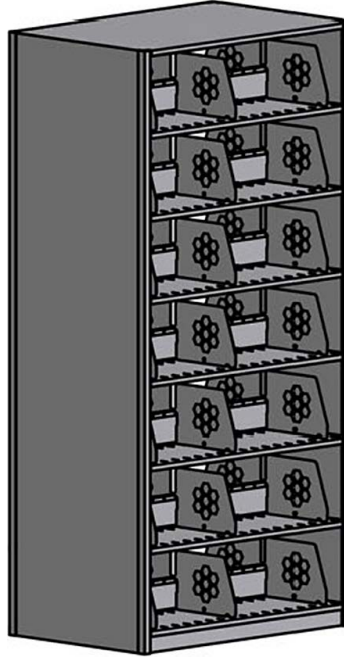

DOUBLE ENTRY STARTER

ATTENTION:
BEFORE STARTING ASSEMBLY,
DETERMINE WHICH STYLE OF
SHELVING IS TO BE BUILT AND
FIND THE CORRESPONDING
SECTION OF THE INSTRUCTIONS.

READ ALL INSTRUCTIONS
BEFORE STARTING ASSEMBLY.

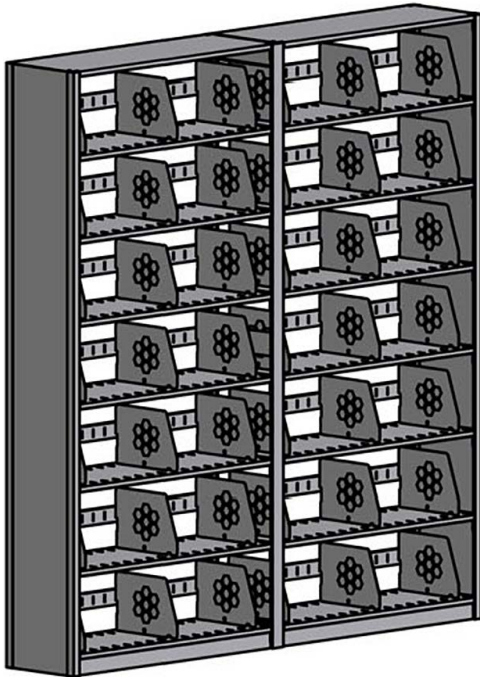

SINGLE ENTRY ROW OF SHELVING

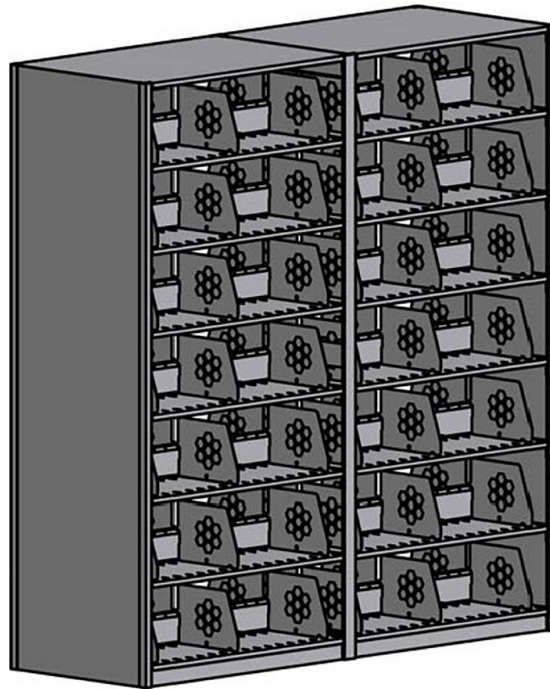

DOUBLE ENTRY ROW OF SHELVING



SINGLE ENTRY STARTER UNIT ASSEMBLY INSTRUCTIONS

TOOLS REQUIRED FOR ASSEMBLY

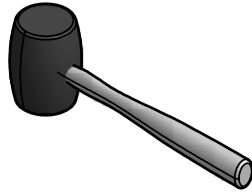

Rubber Mallet

or

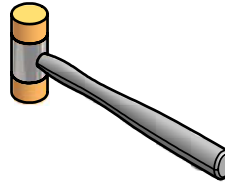

Plastic Tip Hammer

PARTS REQUIRED FOR ASSEMBLY OF SINGLE ENTRY STARTER

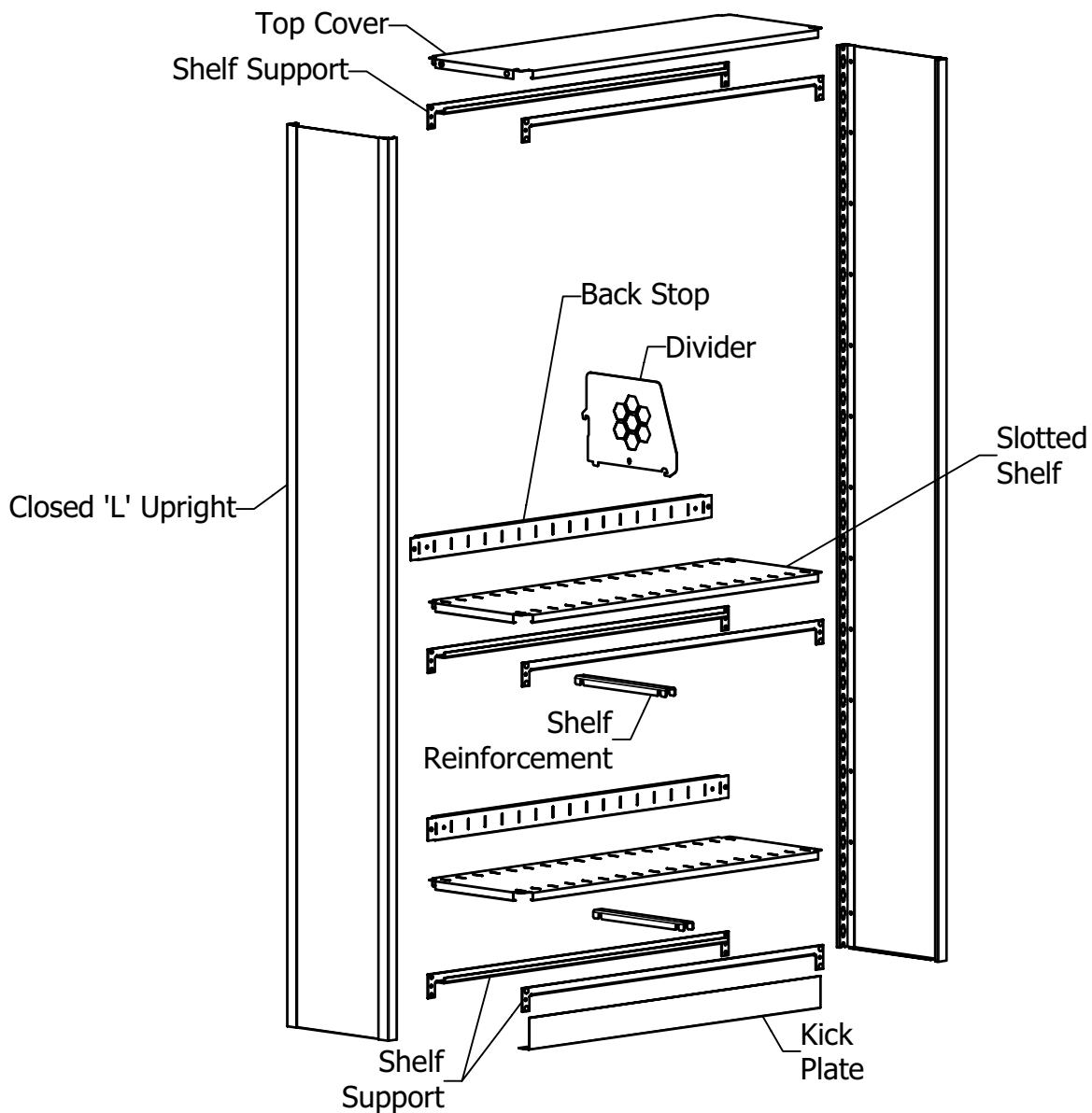

2" Kick Plate
(Typical Configuration)

Figure A

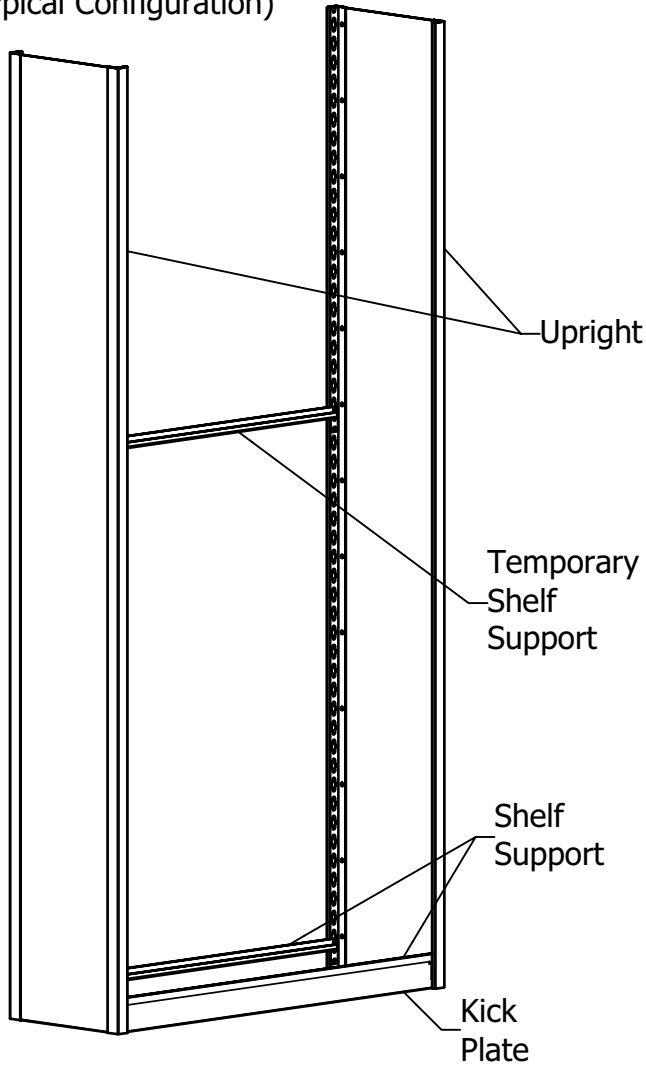

Step 1:

Temporarily mount a shelf support at chest height to hold uprights in position (see Figure A). Rivets of shelf support fit into keyholes on uprights. Use a rubber mallet or plastic tip hammer to tap shelf support into bottom of keyholes.

Step 2:

Depending on configuration ordered, bottom components will be assembled as shown in either Figure A (kick plate) or Figure B (mobile ready).

Note:

The kick plate will be placed against the uprights, the shelf support rivets will be placed into the appropriate keyholes. Using a rubber mallet or plastic tip hammer, tap on the shelf support seating the rivets in the bottom of the keyholes holding the kick plate in place.

Mobile Ready
(Alternate Configuration)

Figure B

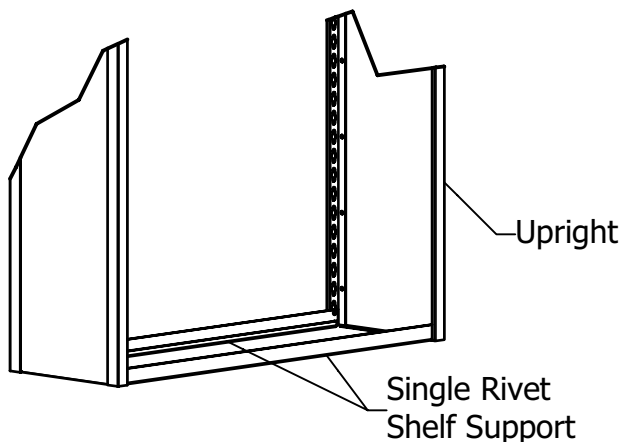
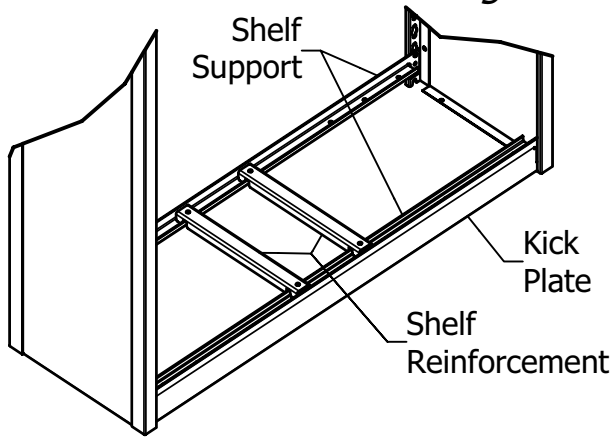

Figure C



Step 3:

If required (See Table 1), install shelf reinforcements as shown in Figure C (for units with kick plate) or Figure D (for mobile ready units).

Table 1 Typical Shelf Reinforcements

Depth of Shelving	No. of Reinforcements
12" (Kick Plate Config)	None
12" (Mobile Ready Config)	One
15" (Kick Plate Config)	None
15" (Mobile Ready Config)	One
18" (Any Config)	Two

Figure D

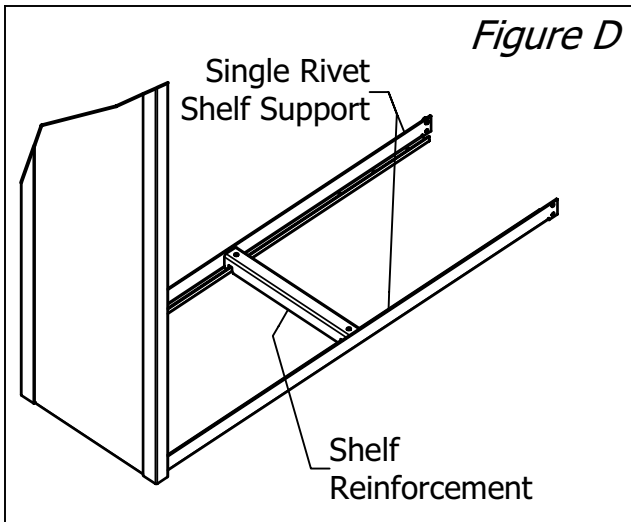
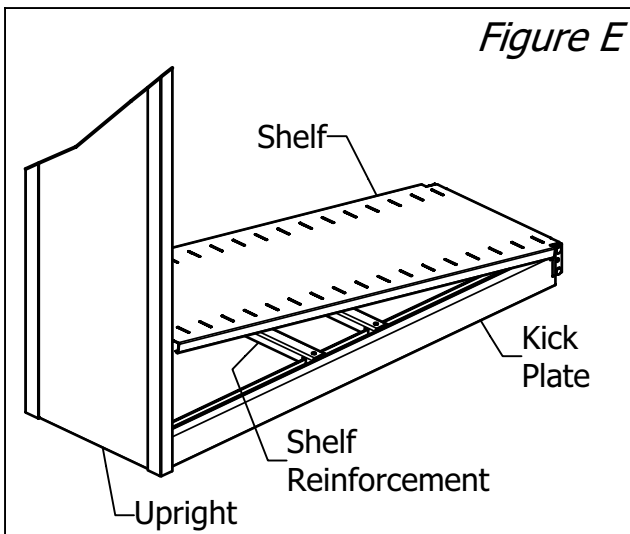

Figure E



Step 4:

Install shelf by tilting as shown in Figure E (kick plate configuration shown). Shelf should then lie flat on shelf support and shelf reinforcement.



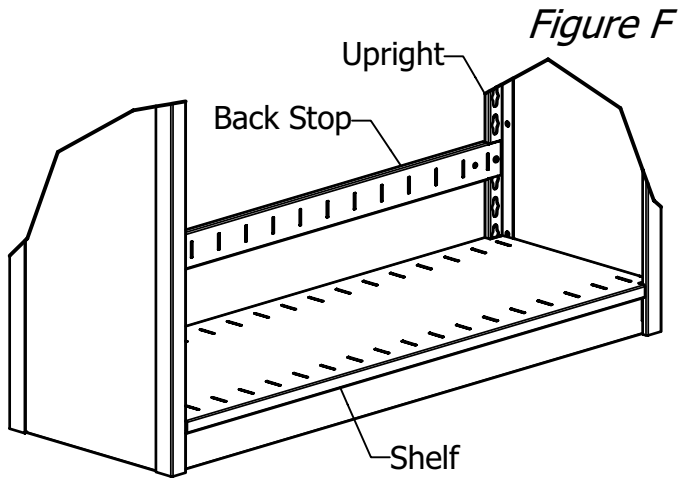

Figure F

Step 5:

Install back stop for bottom shelf. Count up three complete keyholes from top of shelf and place rivets located on each end of back stop in these keyholes (see Figure F).

Step 6:

Install remainder of shelf supports, shelves, back stops, & shelf reinforcements (if required) as previously shown. Keep in mind your installation may be different, as shelf spacing varies from job to job.

Typical Clear Openings for Letter/Legal Shelving

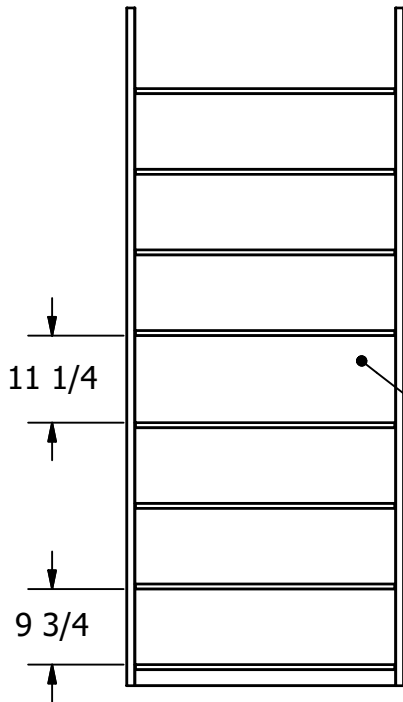

Typical Clear Openings for X-Ray Shelving

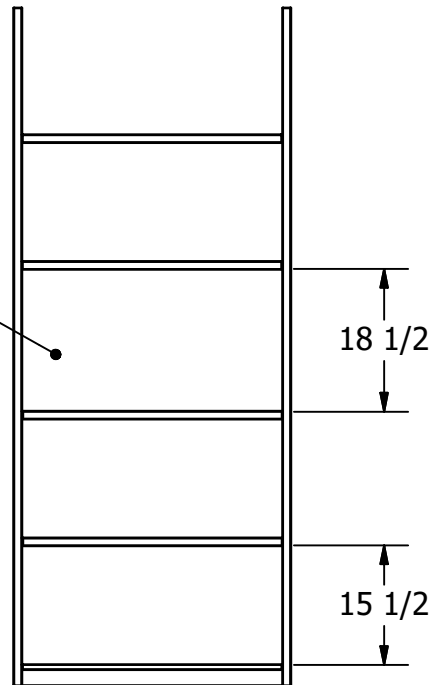

Third Opening Typically Has Posting Shelf (X-Ray)

Fourth Opening Typically Has Posting Shelf (Letter/Legal)

If using or planning to use a posting shelf, leave space for it to be mounted when installing shelf supports and shelves. Not all shelving unit combinations will allow equal spacing of shelves when installing posting shelves. One opening will need to be larger than the rest. Check with your dealer or supplier for the correct choices of uprights and shelf openings required when a posting shelf is desired.



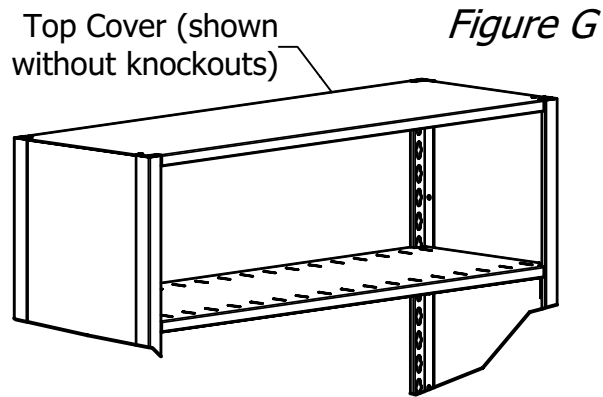

Step 7:

Install top cover the same way shelves were installed. Shelf supports for top cover should be positioned in the top two most keyholes.

Note:

Top shelf does not require shelf reinforcements. Depending on components ordered, top cover may or may not have knockouts in it. Figure G shows top cover without knockouts. Top cover with knockouts is required only when unit is being used on a mobile system.

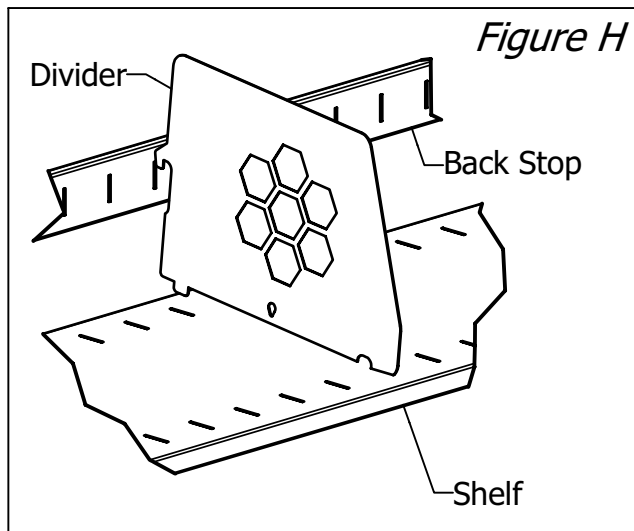

Step 8:

To install dividers, it must be tilted up in back for hook in front to be inserted into front slot. Then tilt rear of divider down into slot on back stop as shown in Figure H.

END OF SECTION FOR SINGLE ENTRY STARTER UNITS



DOUBLE ENTRY STARTER UNIT ASSEMBLY INSTRUCTIONS

TOOLS REQUIRED FOR ASSEMBLY

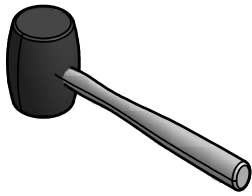

Rubber Mallet

or

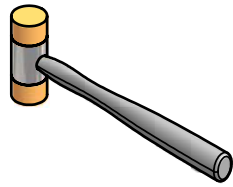

Plastic Tip Hammer



7/16" Wrench

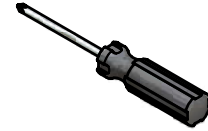

Phillips
Screwdriver

PARTS REQUIRED FOR ASSEMBLY OF DOUBLE ENTRY STARTER

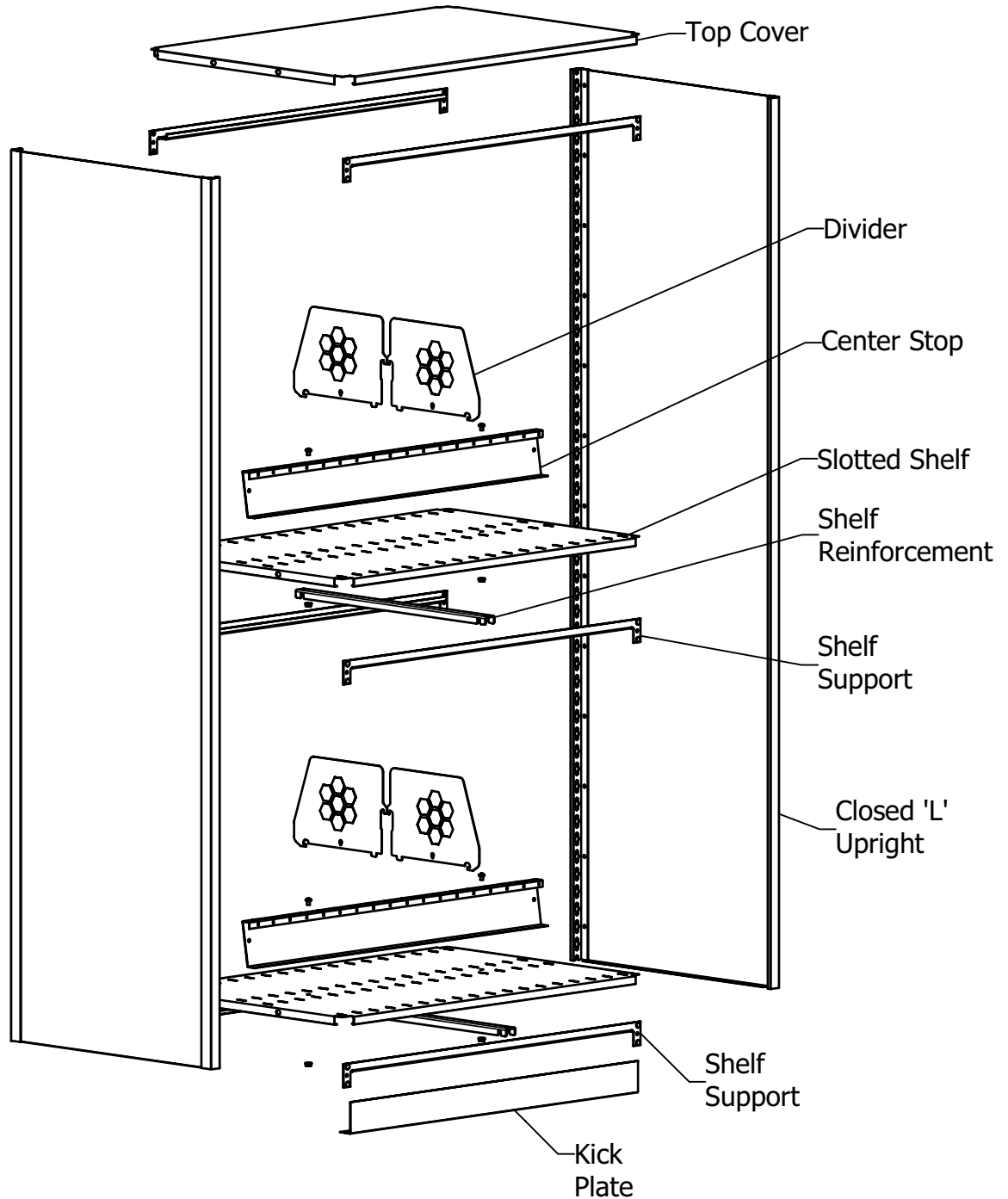

2" Combo Base
(Typical Configuration)

Figure I

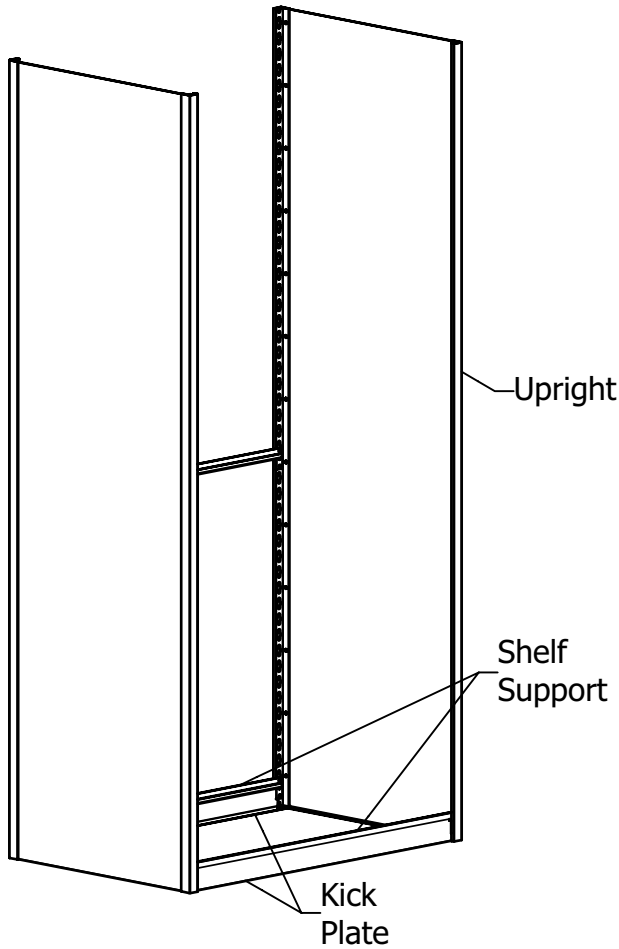

Step 1:

Temporarily mount a shelf support at chest height to hold uprights in position (see Figure I). Rivets of shelf support fit into keyholes on uprights. Use a rubber mallet or plastic tip hammer to tap shelf support into bottom of keyholes.

Step 2:

Depending on configuration ordered, bottom components will be assembled as shown in either Figure I (kick plate) or Figure J (mobile ready).

Mobile Ready
(Alternate Configuration)

Figure J

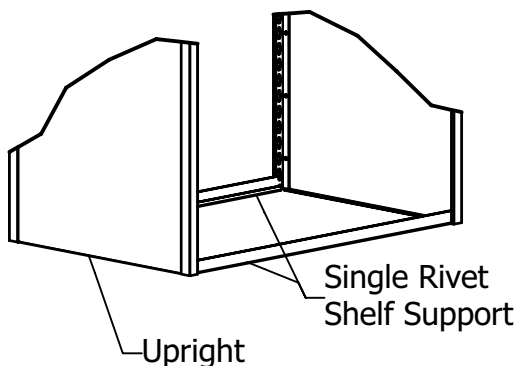

Note:

The kick plate will be placed against the uprights, the shelf support rivets will be placed into the appropriate keyholes. Using a rubber mallet or plastic tip hammer, tap on the shelf support seating the rivets in the bottom of the keyholes holding the kick plate in place.



Figure K

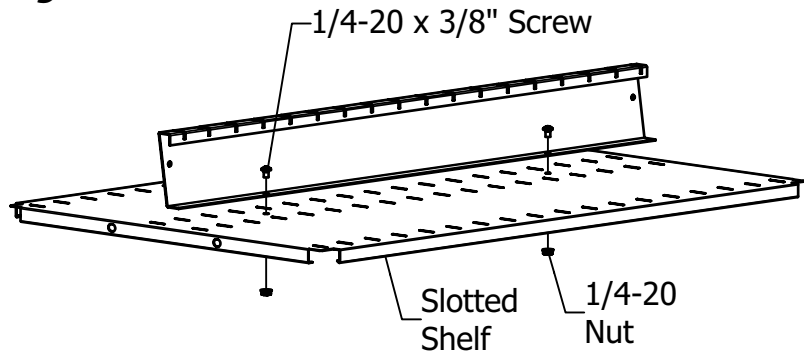

Step 3:

Before mounting shelves in double entry unit, center stops need to be attached to slotted shelves using 1/4-20 hardware as shown in Figure K.

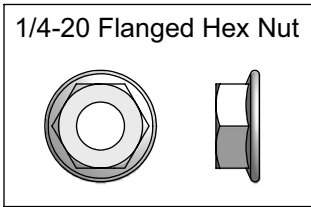
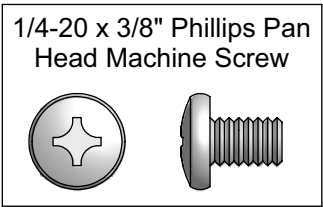
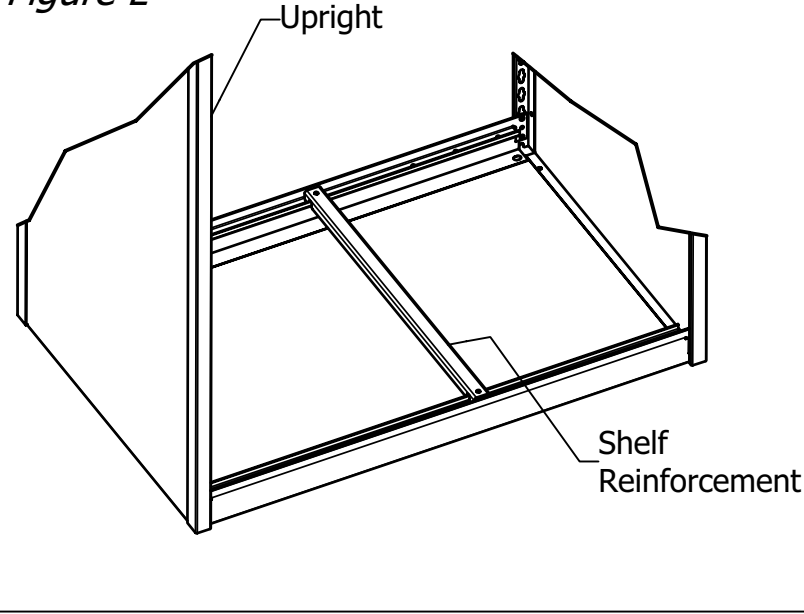

Figure L



Step 4:

Install shelf reinforcements as shown in Figure L. See Table 2 for number of reinforcements per shelf.

Depth of Shelving	No. of Reinforcements
24" (Ltr/Lgl)	One
30" (Ltr/Lgl)	Two
36" (Ltr/Lgl)	Two
up to 36" (X-Ray)	Two
42" (X-Ray)	Three
48" (X-Ray)	Four



Figure M

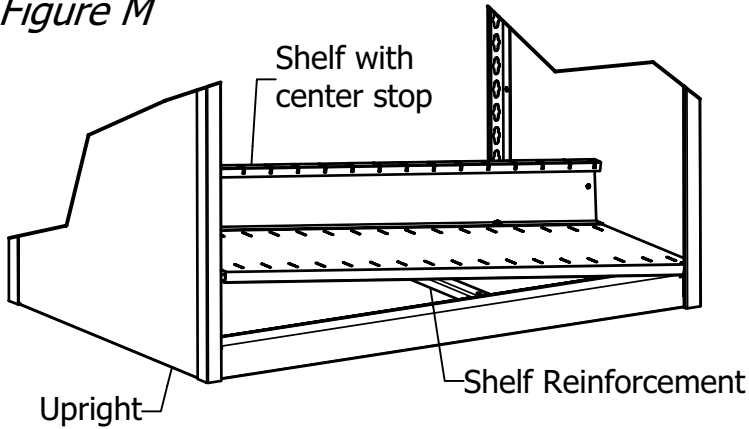

Step 5:

Install shelf by tilting as shown in Figure M. Shelf should then lie flat on combo base and shelf reinforcement.

Step 6:

Install remainder of shelf supports, shelves, & shelf reinforcements (if required) as previously shown. Keep in mind your installation may be different, as shelf spacing varies from job to job.

Typical Clear Openings for Letter/Legal Shelving

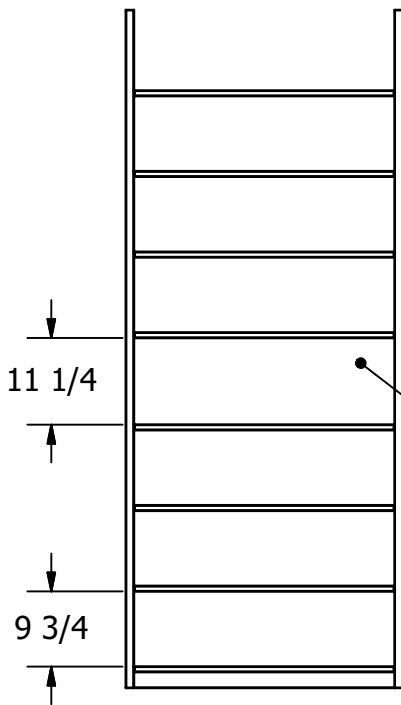

Typical Clear Openings for X-Ray Shelving

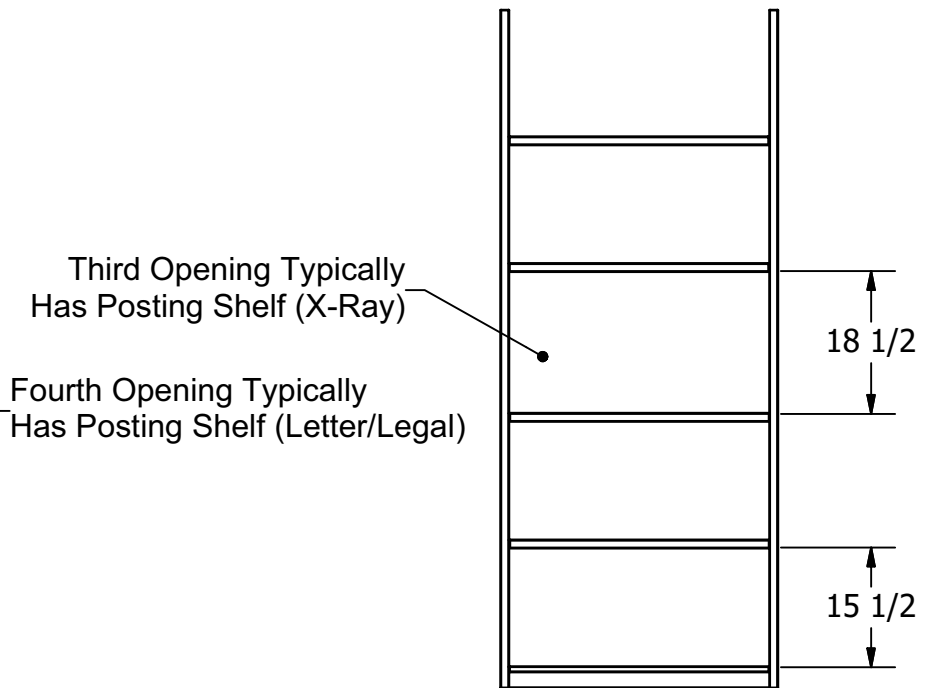

If using or planning to use a posting shelf, leave space for it to be mounted when installing shelf supports and shelves. Not all shelving unit combinations will allow equal spacing of shelves when installing posting shelves. One opening will need to be larger than the rest. Check with your dealer or supplier for the correct choices of uprights and shelf openings required when a posting shelf is desired.



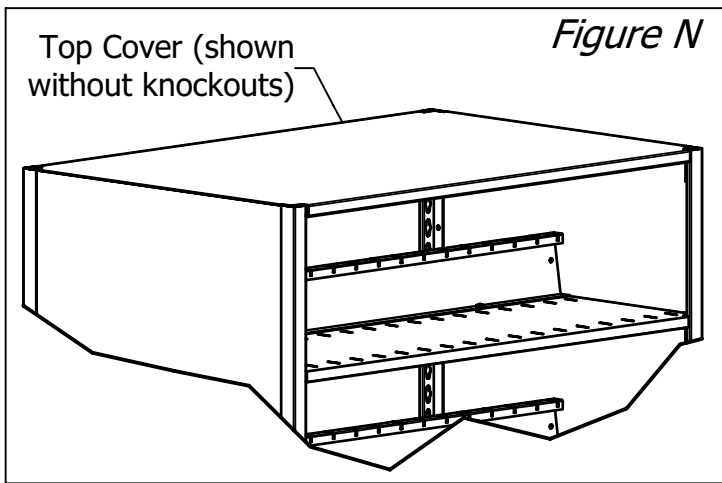

Step 7:

Install top cover the same way shelves were installed. Shelf supports for top cover should be positioned in the top two most keyholes.

Note:

Top shelf does not require shelf reinforcements. Depending on components ordered, top cover may or may not have knockouts in it. Figure N shows top cover without knockouts. Top cover with knockouts is required only when unit is being used on a mobile system.

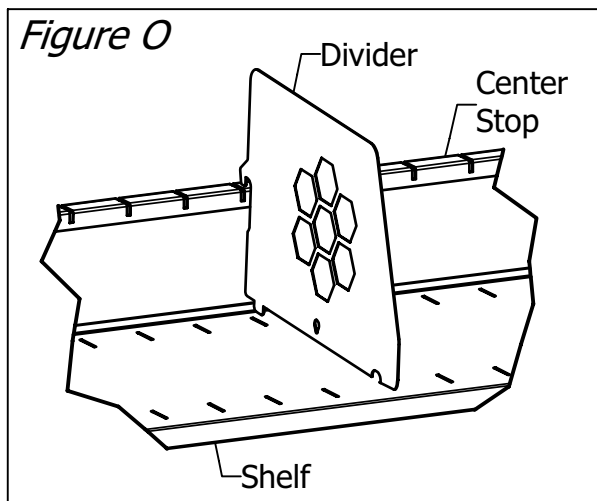

Step 8:

To install dividers, it must be tilted up in back for hook in front to be inserted into front slot. Then tilt rear of divider down into slot on center stop as shown in Figure O.

END OF SECTION FOR DOUBLE ENTRY STARTER UNITS



SINGLE ENTRY ROW OF SHELVING ASSEMBLY INSTRUCTIONS

TOOLS REQUIRED FOR ASSEMBLY

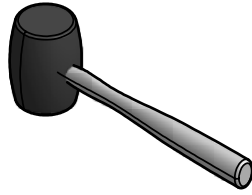

Rubber Mallet

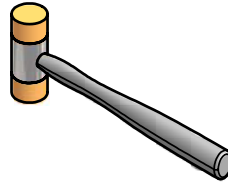

Plastic Tip Hammer

PARTS REQUIRED FOR ASSEMBLY OF SINGLE ENTRY ROW OF SHELVING

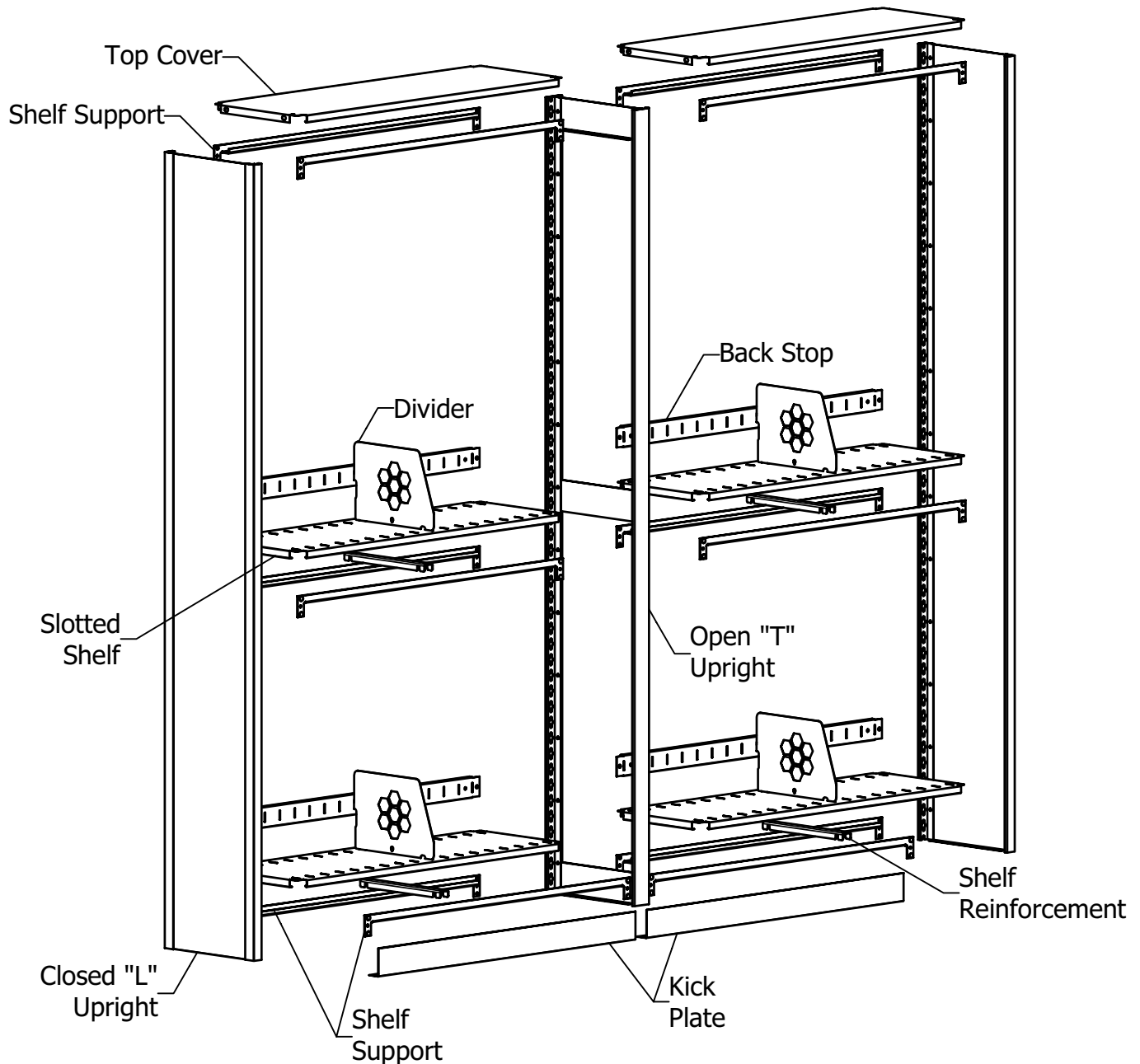

2" Kick Plate
(Typical Configuration)

Figure P

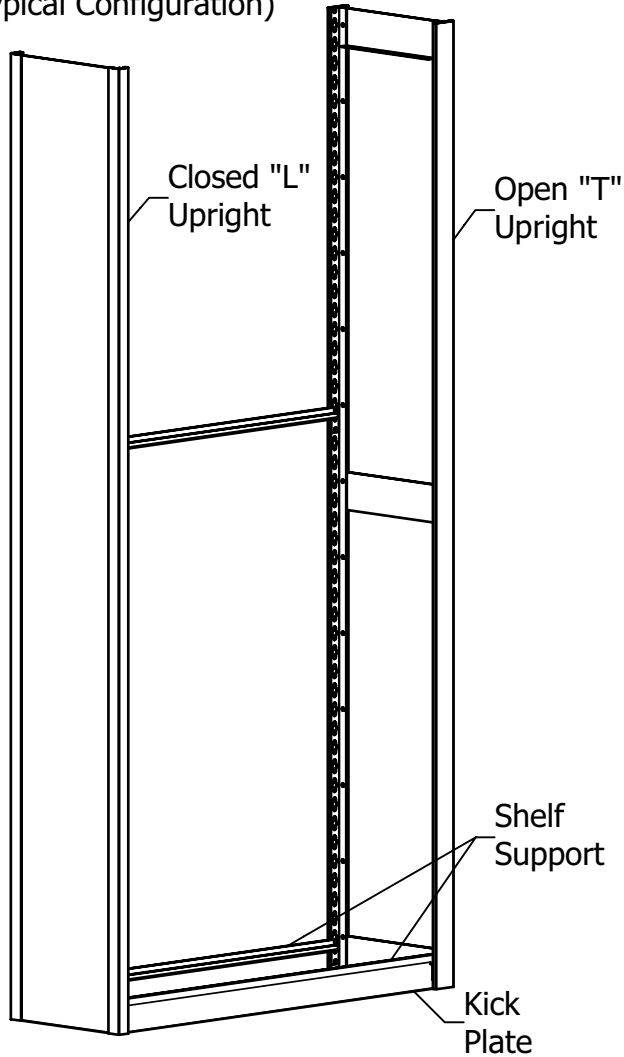

Step 1:

Temporarily mount a shelf support at chest height between a closed "L" upright on left and an open "T" upright on right to hold uprights in position (see Figure P). Rivets of shelf support fit into keyholes on uprights. Use a rubber mallet or plastic tip hammer to tap shelf support into bottom of keyholes.

Step 2:

Depending on configuration ordered, bottom components will be assembled as shown in either Figure P (kick plate) or Figure Q (mobile ready).

Note:

The kick plate will be placed against the uprights, the shelf support rivets will be placed into the appropriate keyholes. Using a rubber mallet or plastic tip hammer, tap on the shelf support seating the rivets in the bottom of the keyholes holding the kick plate in place.

Mobile Ready
(Alternate Configuration)

Figure Q

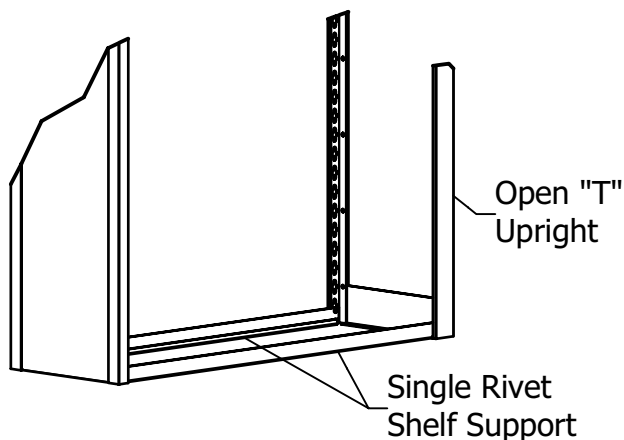
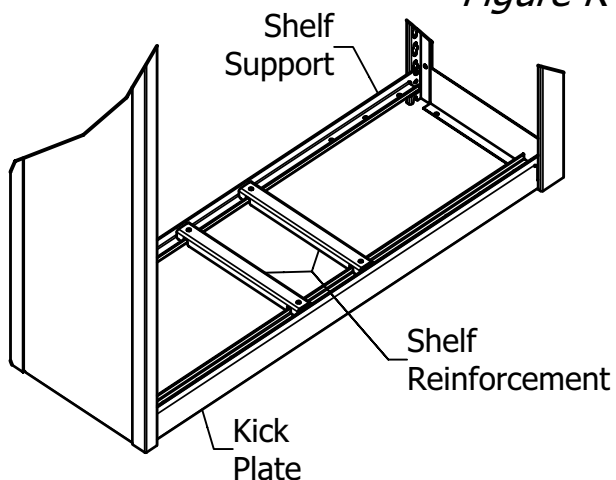

Figure R



Step 3:

If required (See Table 3), install shelf reinforcements as shown in Figure R (for units with kick plate) or Figure S (for mobile ready units).

Table 3 Typical Shelf Reinforcements	
Depth of Shelving	No. of Reinforcements
12" (Kick Plate Config)	None
12" (Mobile Ready Config)	One
15" (Kick Plate Config)	None
15" (Mobile Ready Config)	One
18" (Any Config)	Two

Figure S

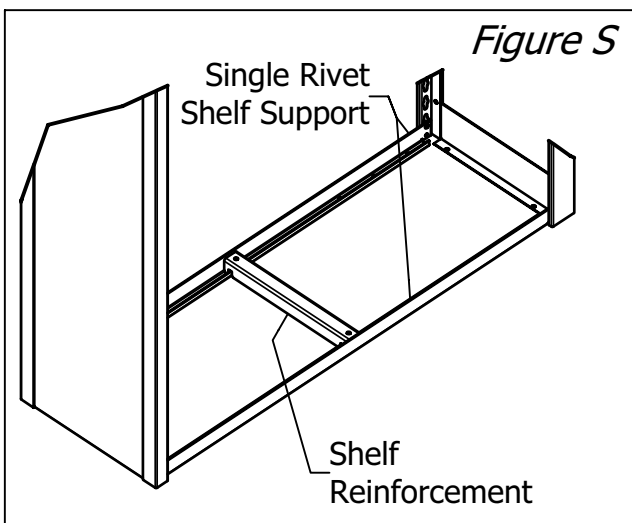
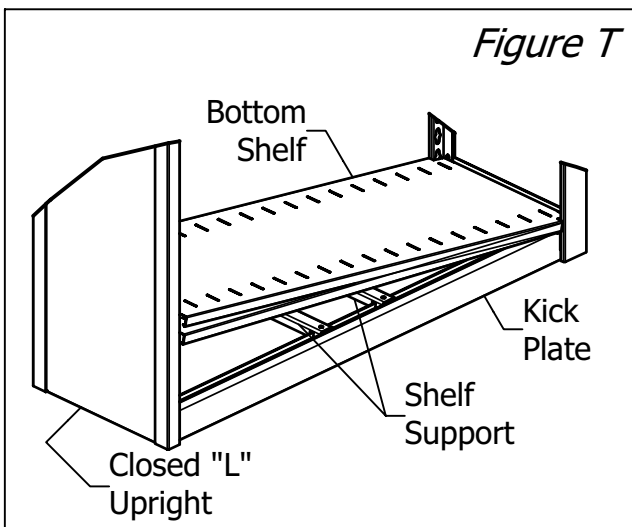

Figure T



Step 4:

Install bottom shelf by tilting as shown in Figure T (kick plate configuration shown). Shelf should then lie flat on combo base and shelf support.



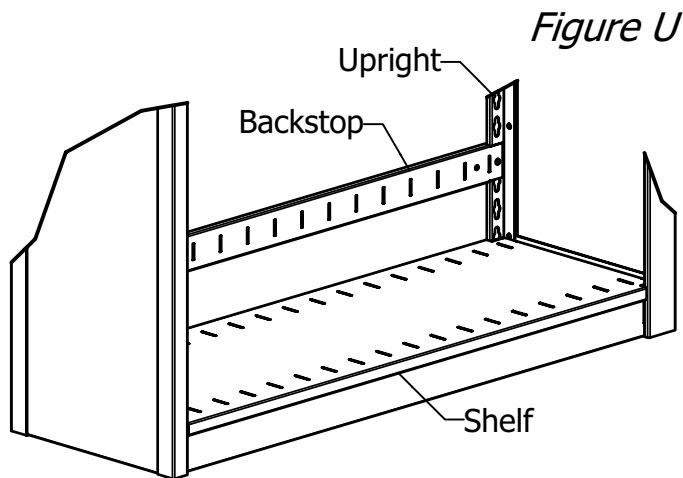

Figure U

Step 5:

Install back stop for bottom shelf. Count up three complete keyholes from top of shelf and place rivets located on each end of back stop in these keyholes (see Figure U).

Step 6:

Install remainder of shelf supports, shelves, back stops, & shelf reinforcements (if required) as previously shown. Keep in mind your installation may be different, as shelf spacing varies from job to job.

Typical Clear Openings for Letter/Legal Shelving

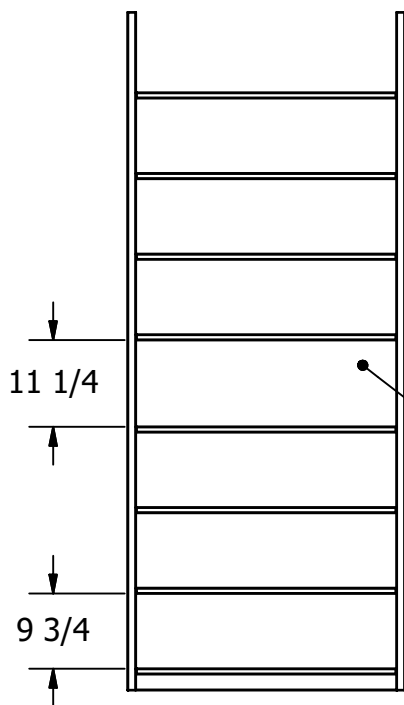

Typical Clear Openings for X-Ray Shelving

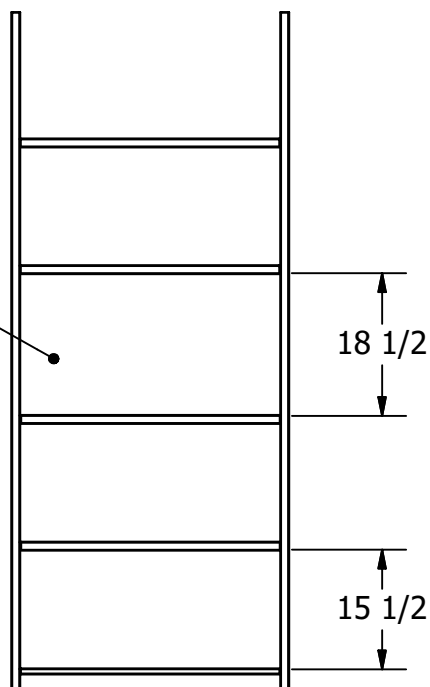

Third Opening Typically Has Posting Shelf (X-Ray)

Fourth Opening Typically Has Posting Shelf (Letter/Legal)

If using or planning to use a posting shelf, leave space for it to be mounted when installing shelf supports and shelves. Not all shelving unit combinations will allow equal spacing of shelves when installing posting shelves. One opening will need to be larger than the rest. Check with your dealer or supplier for the correct choices of uprights and shelf openings required when a posting shelf is desired.



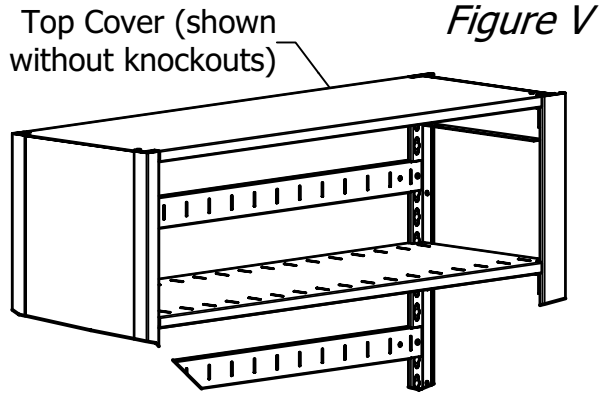

Step 7:
Install top cover the same way shelves were installed. Shelf supports for top cover should be positioned in the top two most keyholes.

Note:
Top shelf does not require shelf reinforcements. Depending on components ordered, top cover may or may not have knockouts in it. Figure V shows top cover without knockouts. Top cover with knockouts is required only when unit is being used on a mobile system.

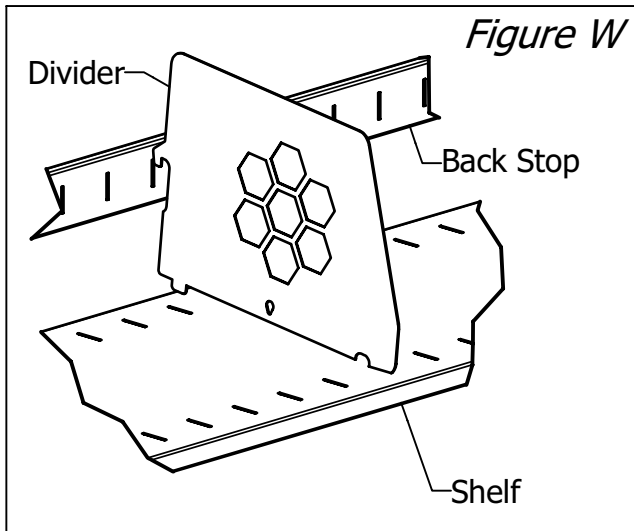

Step 8:
To install dividers, it must be tilted up in back for hook in front to be inserted into front slot. Then tilt rear of divider down into slot on back stop as shown in Figure W.



Figure X

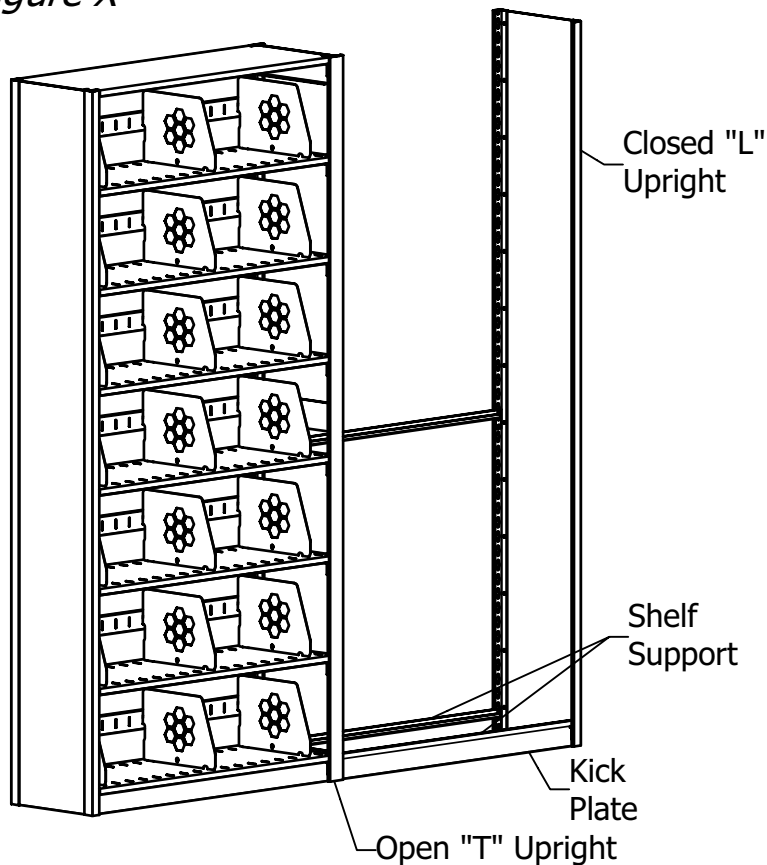

Note:

If your shelving consists of only 2 sections (Figure X), continue with step 9a. If your shelving consists of 3 or more sections (Figure Y) skip to step 9b at the bottom of this page.

Step 9a:

Position a closed "L" upright to the right of existing section and install base components as in Steps 1 & 2 (Figure X).

Figure Y

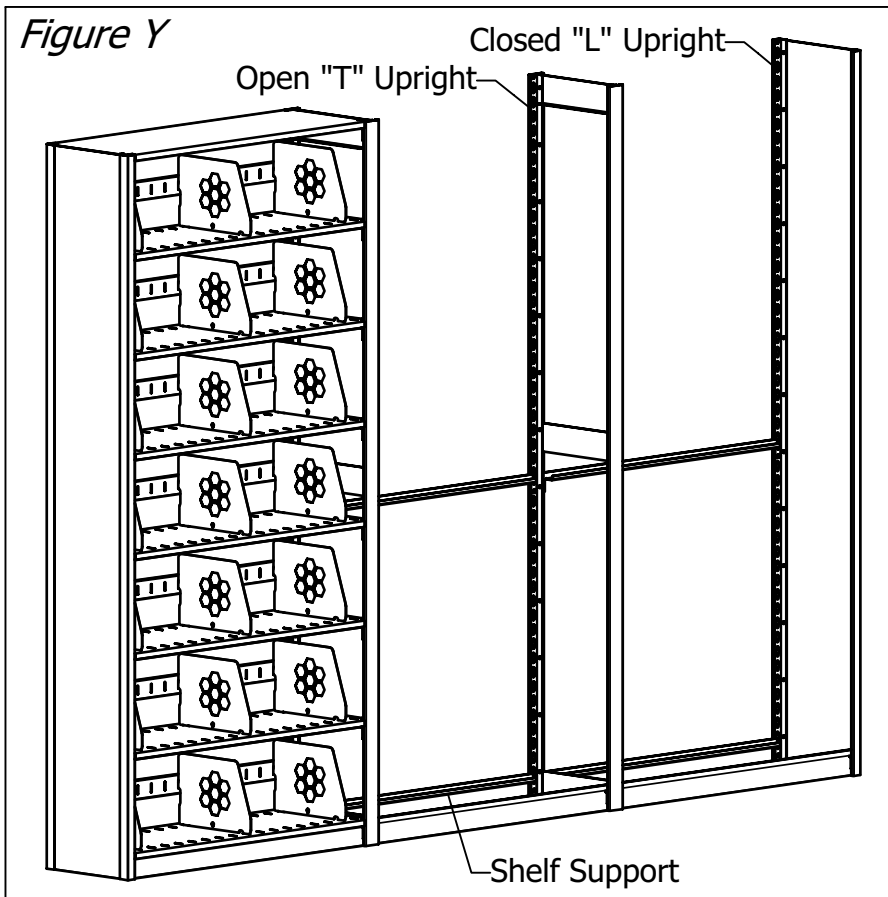

Step 9b:

Repeat Steps 1 & 2 substituting an open "T" upright for a closed "L" upright. Only the uprights at either end of the row will be closed uprights (See Figure Y).

Step 10:

Repeat Steps 3 thru 8 as needed to complete remaining units.

**END OF SECTION FOR
SINGLE ENTRY ROW
OF UNITS**



DOUBLE ENTRY ROW OF SHELVING ASSEMBLY INSTRUCTIONS

TOOLS REQUIRED FOR ASSEMBLY

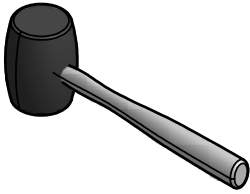

Rubber Mallet

or

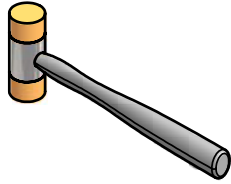

Plastic Tip Hammer



7/16" Wrench

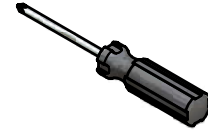

Phillips
Screwdriver

PARTS REQUIRED FOR ASSEMBLY OF DOUBLE ENTRY ROW OF SHELVING

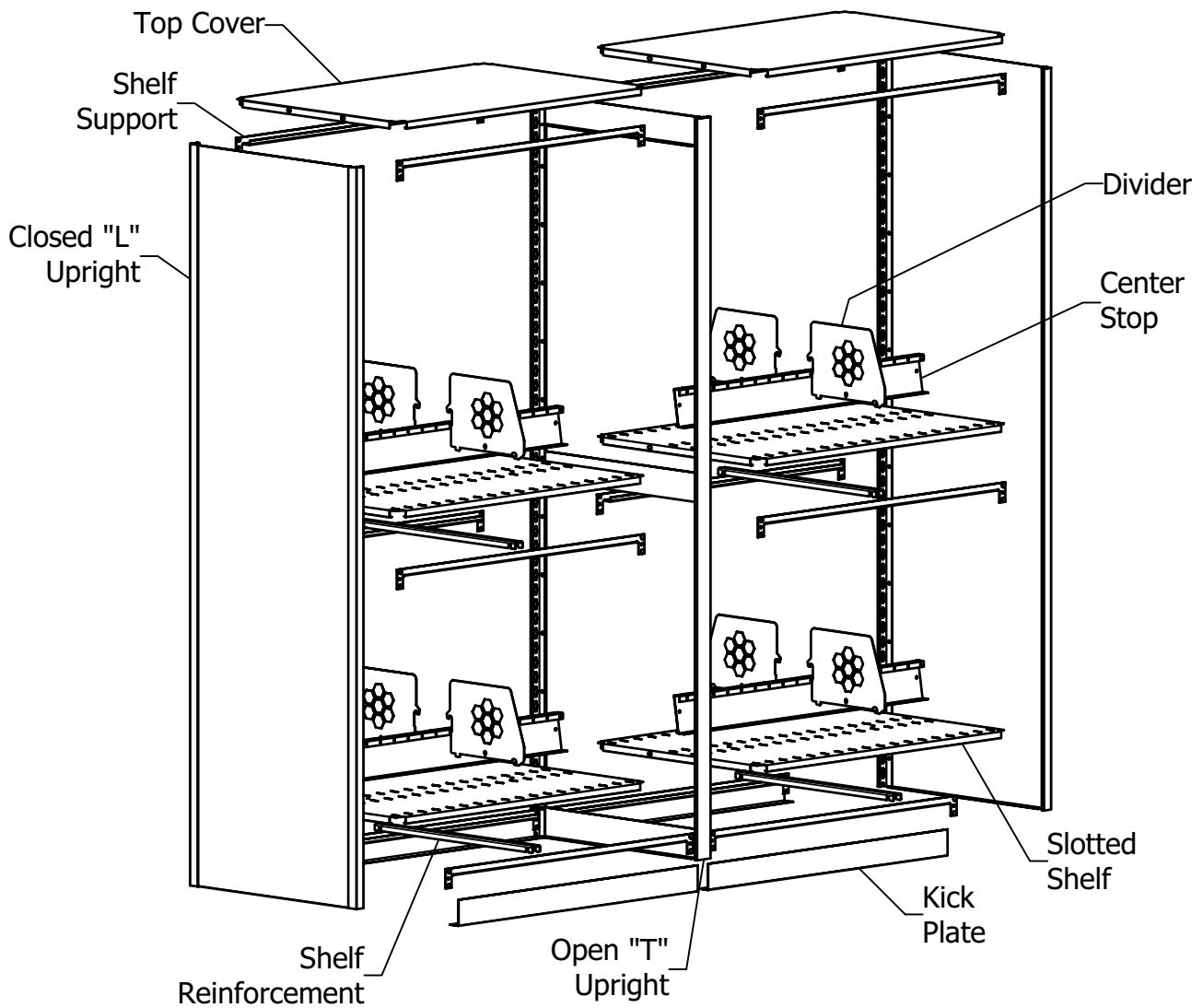

2" Kick Plate
(Typical Configuration)

Figure Z

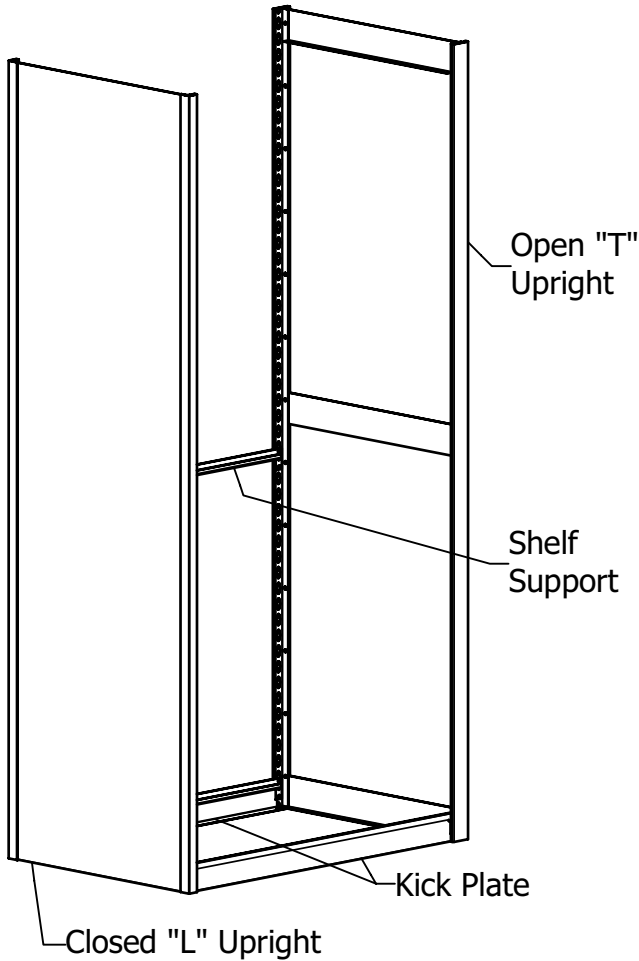

Step 1:

Temporarily mount a shelf support at chest height between a closed "L" upright on left and an open "T" upright on right to hold uprights in position (see Figure Z). Rivets of shelf support fit into keyholes on uprights. Use a rubber mallet or plastic tip hammer to tap shelf support into bottom of keyholes.

Step 2:

Depending on configuration ordered, bottom components will be assembled as shown in either Figure Z (kick plate) or Figure AA (mobile ready).

Mobile Ready
(Alternate Configuration)

Figure AA

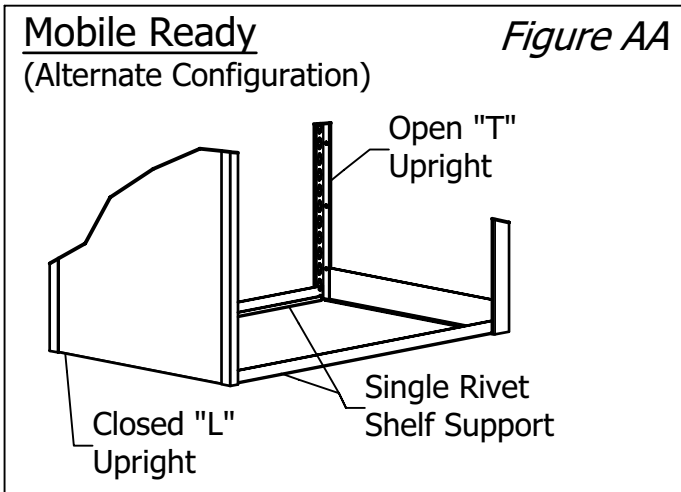
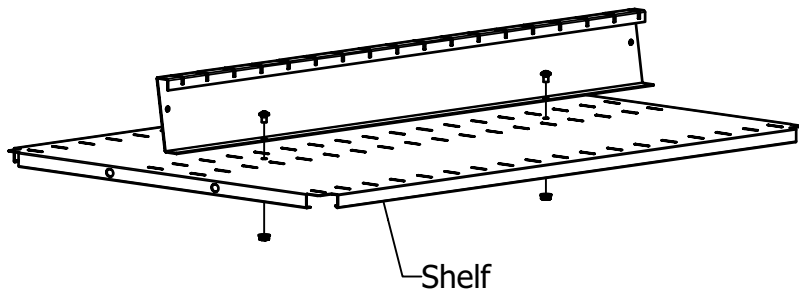
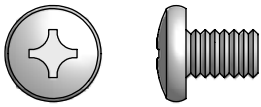

Figure AB



1/4-20 x 3/8" Phillips Pan Head Machine Screw



1/4-20 Flanged Hex Nut

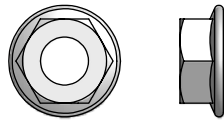

Step 3:

Before mounting shelves in double entry unit, center stops need to be attached to slotted shelves using 1/4-20 hardware as shown in Figure AB.

Figure AC

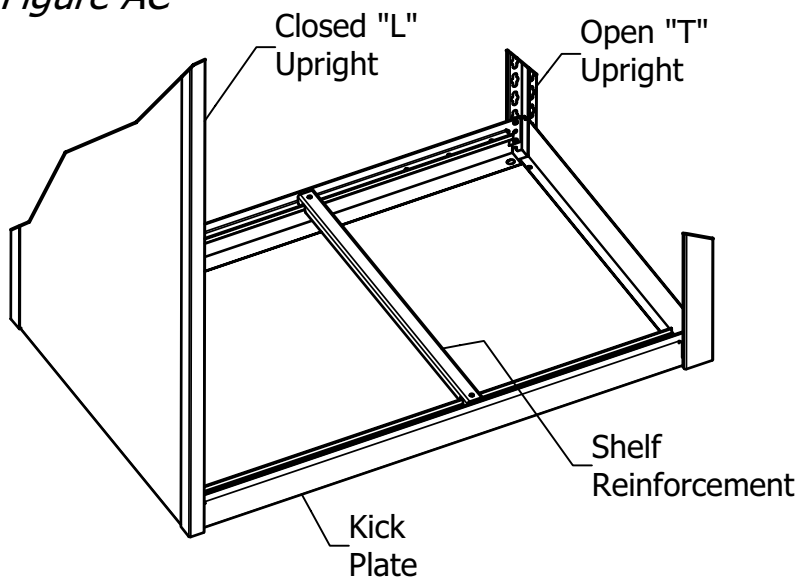

Step 4:

Install shelf reinforcements as shown in Figure AC. See Table 4 for number of reinforcements per shelf.

Table 4 Typical Shelf Reinforcements

Depth of Shelving	No. of Reinforcements
24" (Ltr/Lgl)	One
30" (Ltr/Lgl)	Two
36" (Ltr/Lgl)	Two
up to 36" (X-Ray)	Two
42" (X-Ray)	Three
48" (X-Ray)	Four



Figure AD

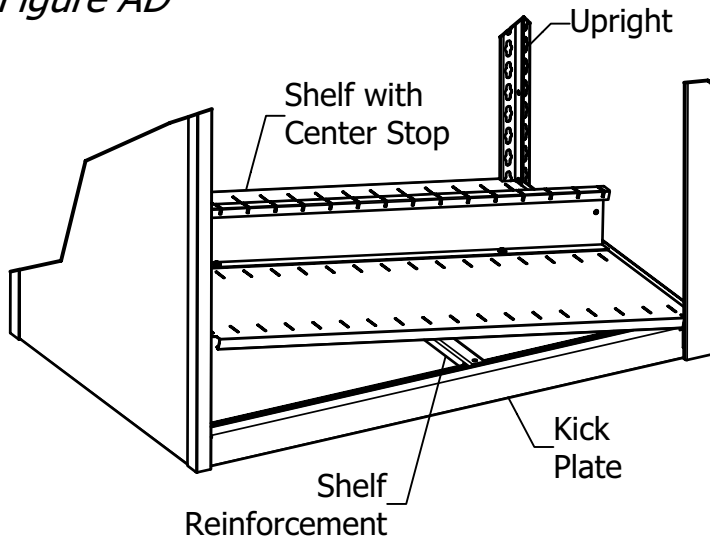

Step 5:

Install shelf by tilting as shown in Figure AD. Shelf should then lie flat on shelf support and shelf reinforcement.

Step 6:

Install remainder of shelf supports, shelves, & shelf reinforcements (if required) as previously shown. Keep in mind your installation may be different, as shelf spacing varies from job to job.

Typical Clear Openings for Letter/Legal Shelving

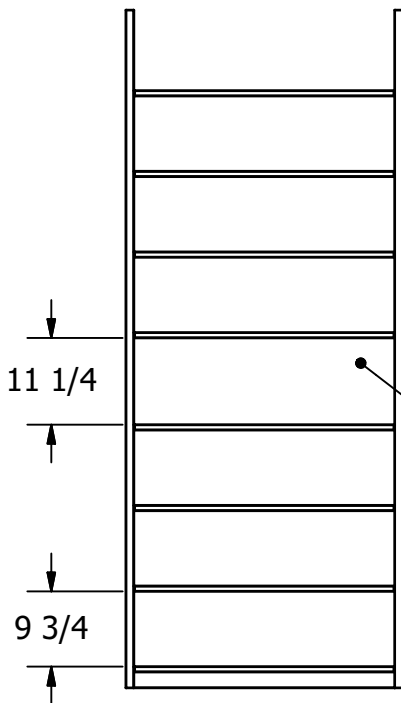

Typical Clear Openings for X-Ray Shelving

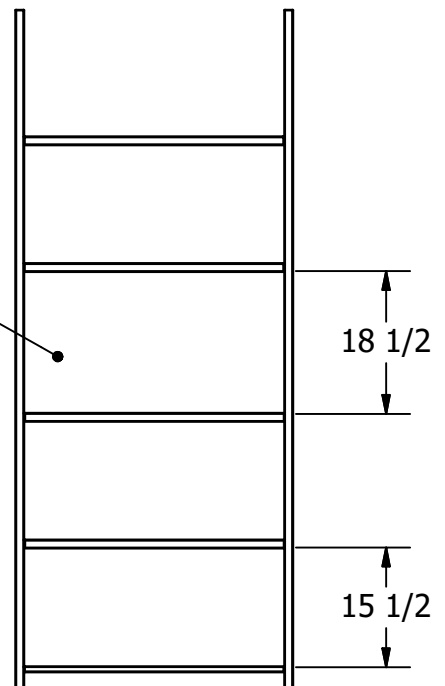

Third Opening Typically Has Posting Shelf (X-Ray)
Fourth Opening Typically Has Posting Shelf (Letter/Legal)

If using or planning to use a posting shelf, leave space for it to be mounted when installing shelf supports and shelves. Not all shelving unit combinations will allow equal spacing of shelves when installing posting shelves. One opening will need to be larger than the rest. Check with your dealer or supplier for the correct choices of uprights and shelf openings required when a posting shelf is desired.



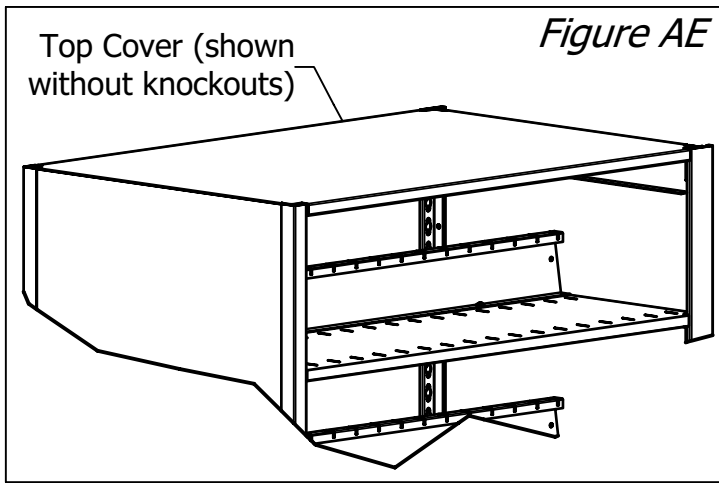

Step 7:

Install top cover the same way shelves were installed. Shelf supports for top cover should be positioned in the top two most keyholes.

Note:

Top shelf does not require shelf reinforcements. Depending on components ordered, top cover may or may not have knockouts in it. Figure AE shows top cover without knockouts. Top cover with knockouts is required only when unit is being used on a mobile system.

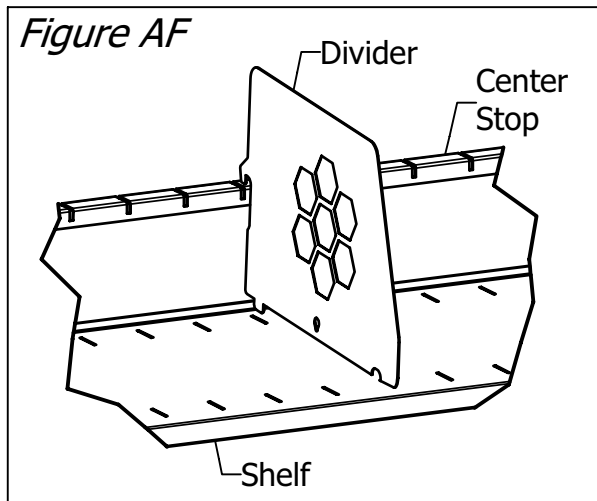

Step 8:

To install dividers, it must be tilted up in back for hook in front to be inserted into front slot. Then tilt rear of divider down into slot on center stop as shown in Figure AF.



Figure AG

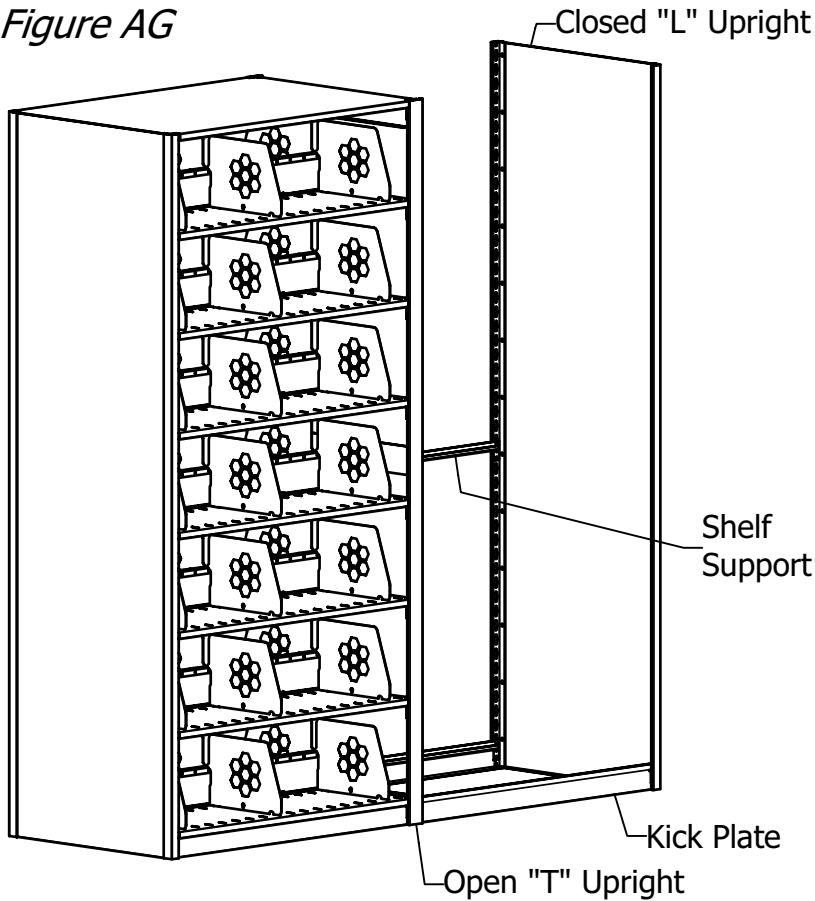

Note:

If your shelving consists of only 2 sections (Figure AG), continue with step 9a. If your shelving consists of 3 or more sections (Figure AH) skip to step 9b at the bottom of this page.

Step 9a:

Position a closed "L" upright to the right of existing section and install base components as in Steps 1 & 2 (Figure AG).

Figure AH

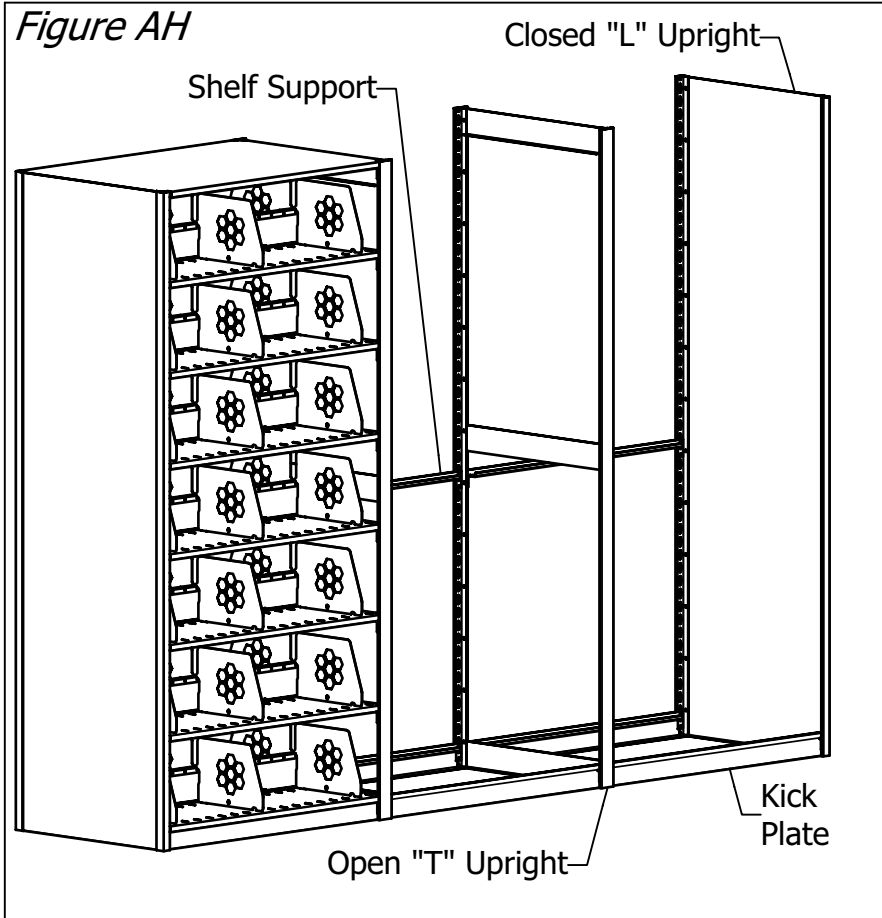

Step 9b:

Repeat Steps 1 & 2 substituting an open "T" upright for a closed "L" upright. Only the uprights at either end of the row will be closed uprights (See Figure AH).

Step 10:

Repeat Steps 3 thru 8 as needed to complete remaining units.

**END OF SECTION FOR
DOUBLE ENTRY ROW
OF UNITS**



4Post Plan Divider Assembly Instructions

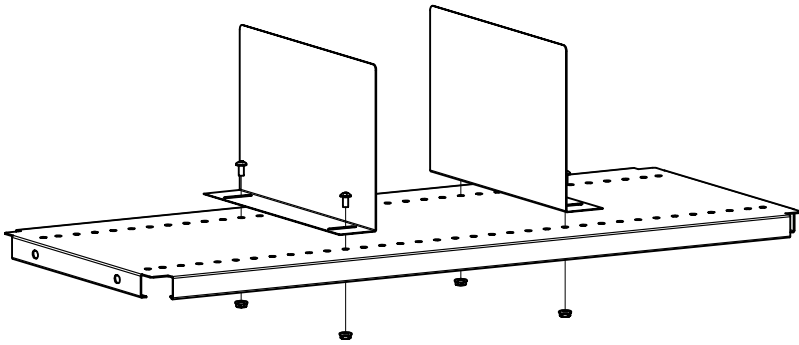

STEP 1

The bottom shelf should be assembled before being placed on the shelf supports. Place bin dividers at the desired locations and attach using the supplied hardware.

STEP 2

Assemble the uprights and base components following the steps in "4Post Shelving Assembly Instructions." Refer to the Quotation/Order to verify whether or not shelf reinforcements are required. Place the shelf from Step 1 on the shelf supports.

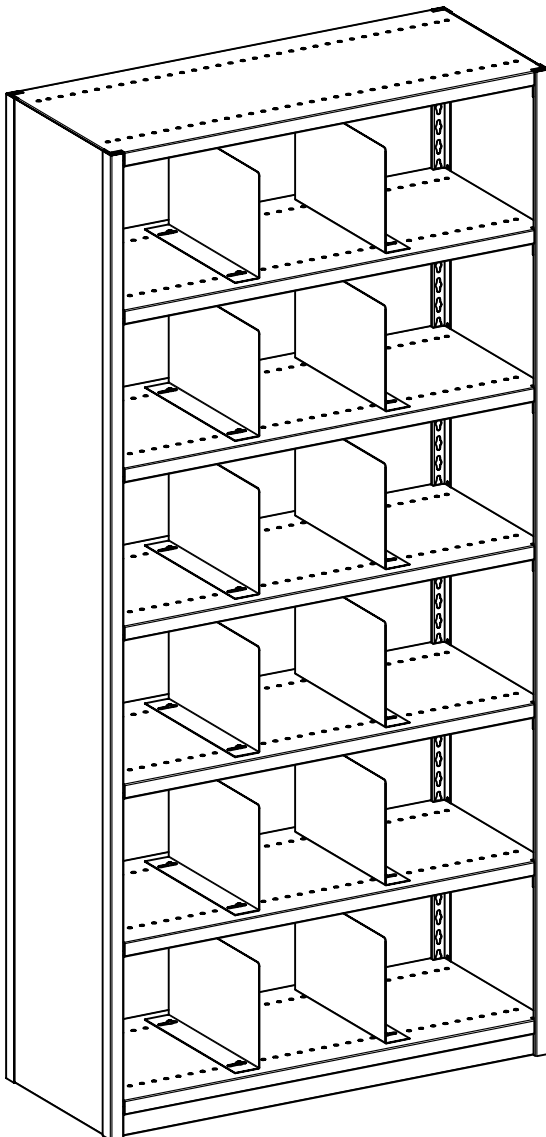
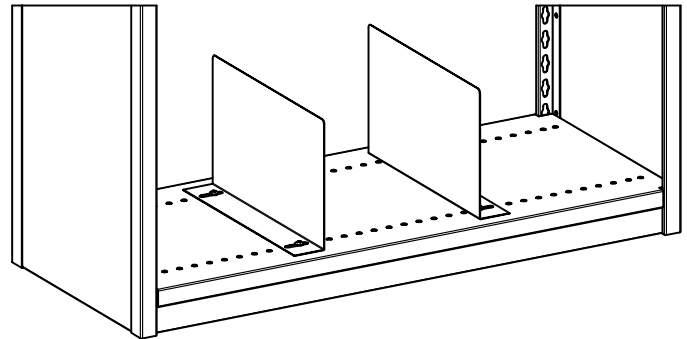

STEP 3

Repeat steps 1 & 2 for the remaining shelves.

END OF INSTRUCTIONS.

FOR ASSEMBLY ASSISTANCE CONTACT CUSTOMER SERVICE AT 1-866-217-0330 (MONDAY THROUGH FRIDAY, 8AM TO 5PM EST).

