

Artwork Storage Rack Assembly Guide

SMS-08-V65-1H6700K

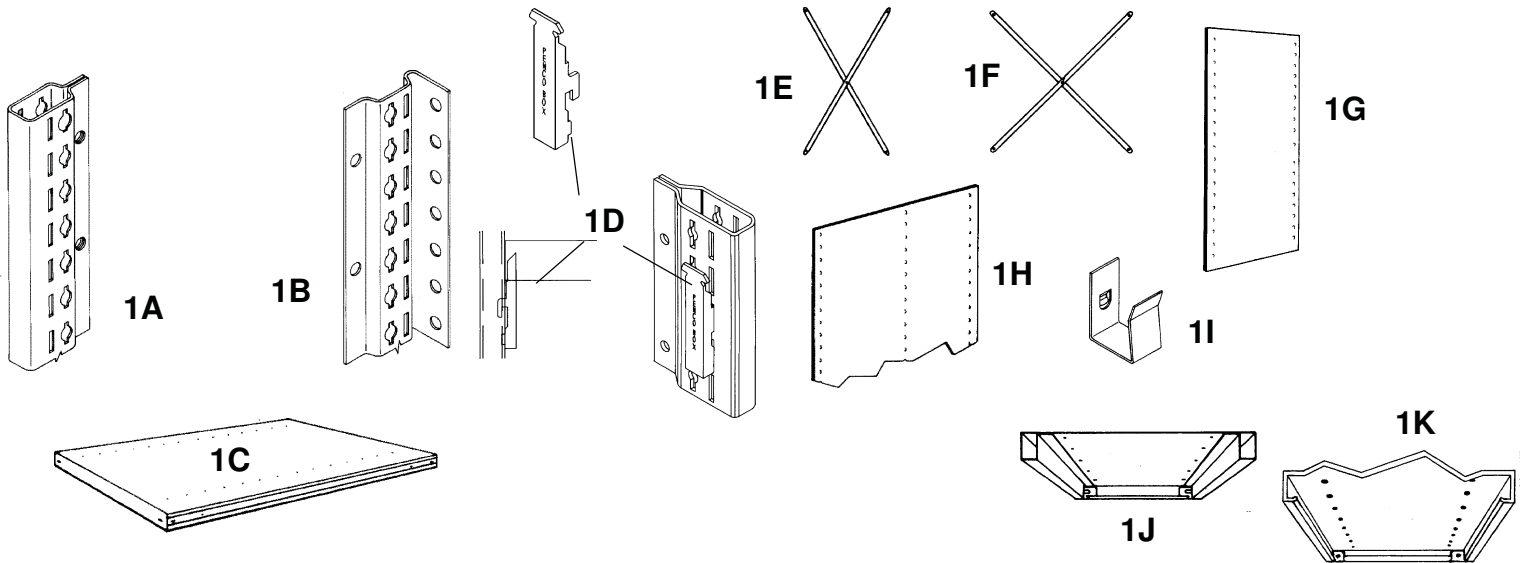

Parts

1A BOX POST (FRONT ONLY) **1B** OFFSET
ANGLE POST **1C** SHELF
1D CLIPPER SHELF CLIP

IMPORTANT NOTE

Shelf clip must be seated properly on posts by lightly tapping top of clip into slots. See illustration.

1E SIDE SWAY BRACE
1F BACK SWAY BRACE
1G SIDE PANEL
1H BACK PANEL
1I BACK PANEL CLIP
1J HI-PERFORMANCE® SHELF **1K**
CONVENTIONAL FLANGE SHELF

CAUTION

It is the responsibility of the persons assembling the shelving to properly install all components and hardware as specified in these instructions and any accompanying drawings for specific installations.

- Install all required Side and Back Sway Braces
- Install Foot Plates and Shims if required
- Tighten all hardware securely

General Instructions

1. Check the number of packages (parts) received against the bill of lading. If any shortages, secure a "shortage notation" from the carrier and file a claim. Check material for damage. If any is damaged, secure a "damaged notation" from the carrier and file a claim against carrier.
2. When unpacking, arrange like parts together as close as possible to the area in which they are to be assembled.
3. Tools required are slotted screw driver and 7/16" and 1/2" socket wrenches to tighten bolts and nuts.
4. Use the proper size bolts for each part. Use no more than the number of clips or bolts that are allowed for each part.
5. Read remainder of these instructions carefully before you proceed further. Familiarize yourself with all component names.
6. Carefully lay out shelving positions on floor (chalk line suggested).
7. Now follow the detailed instructions step by step.



Open Shelving

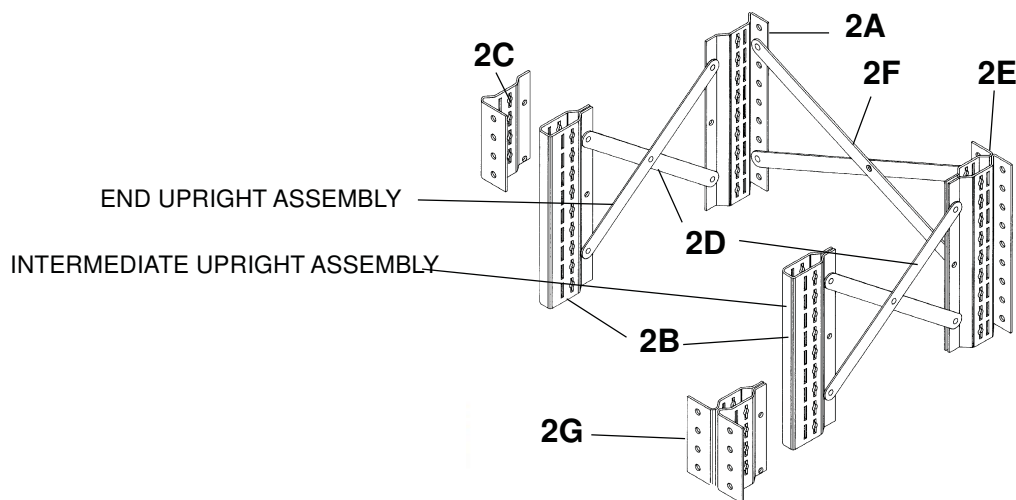
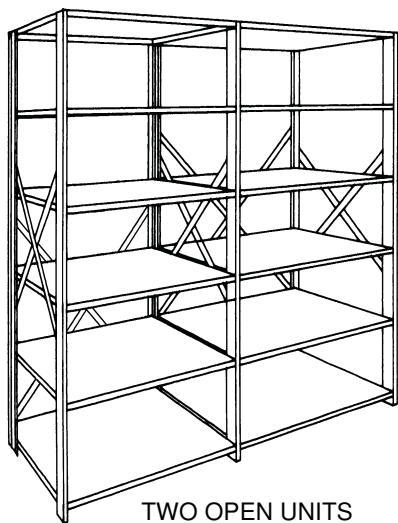

PARTS DESCRIPTION

2A OFFSET ANGLE POST AT REAR

2B BOX POST (FRONT ONLY)

2C OFFSET ANGLE POSTS AT FRONT **2D** SIDE SWAY BRACE

2E TWO OFFSET ANGLE POSTS AT REAR **2F** BACK SWAY BRACE

2G TWO OFFSET ANGLE POSTS IF USED AT FRONT

1. Pre-Clip posts by installing Clipper Shelf Clips where the shelves will be located and tap them downward to engage the clip hook in the post (see page 1).
2. End or intermediate side frame assemblies are made by connecting the required posts with side braces. Place the proper front and rear post on the floor (or table) parallel to each other and spaced apart to match the depth of the unit you are building. Place braces on the inside of the post approximately at midpoint of the height of the unit. Select the proper brace, bolt together at the center using a 1/4"-20 x 1/2" truss head bolt and hex nut to form an "X". Bolt the brace to the side of the rear flanges of posts with four 1/4"-20 x 1/2" truss head bolts and hex nuts.
3. Stand two assemblies upright. Move them into position and set a shelf into the top and into the bottom sets of pre-clipped shelf clips. Press each shelf downward so that it is seated on each of the four clips. Repeat this procedure with the intermediate shelves.
4. Select the proper back brace, bolt together at the center using a 1/4"-20 x 1/2" truss head bolt and hex nut to form an "X". Attach the back sway braces to the rear flanges of offset angle post with four 1/4"-20 x 1/2" bolts and nuts. Place the bottom holes of the brace 3" to 6" of the floor. For an adjacent unit it is recommended that bracing be staggered up and down (see illustration above).
5. If double row, assemble the front row as above, then assemble the rear row the same as above, except use a common pair of back braces placed inside the posts of one unit and tie the rows together using the same bolts and nuts used on back braces.



Closed Shelving

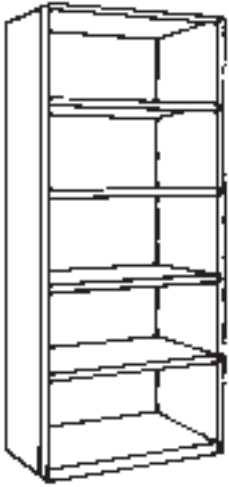

Unit above shown
with optional front
base

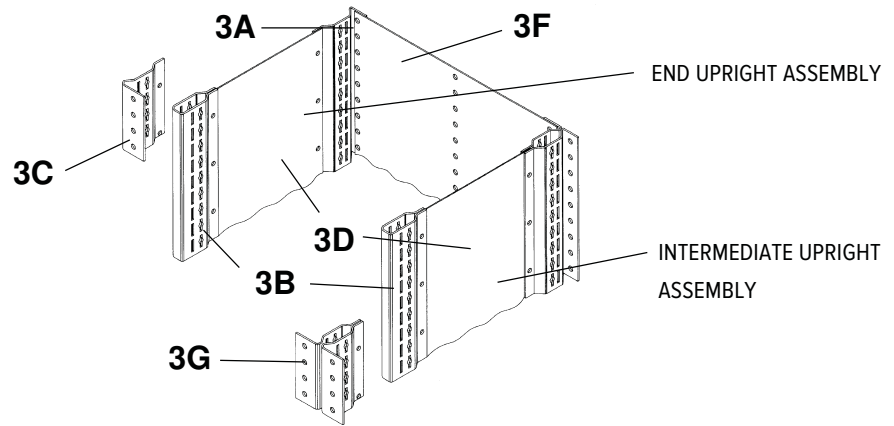

PARTS DESCRIPTION

3A OFFSET ANGLE POST AT REAR 3B BOX POST (FRONT ONLY)

3C OFFSET ANGLE POSTS AT FRONT 3D SIDE PANEL

3E TWO OFFSET ANGLE POSTS AT REAR 3F BACK PANEL

3G TWO OFFSET ANGLE POSTS AT FRONT

1. Pre-Clip posts by installing Clipper Shelf Clips where the shelves will be located (see page 1).
2. Assemble end and intermediate side panel assemblies. Slip the panel between the flanges of the box post and on the inside of the flange on the back post. Intermediate side panels must be placed between the flanges of the back posts. Bolt the assemblies together using 1/4" -20 x 1/2" bolts and nuts through the first hole from each end. Bolt panels to the post approximately every 12" (30 cm). On end panel assemblies bolt some additional locations to hold the panel against the angle post.
3. Stand panels upright. Move the two panels into position and set a shelf into the top and into the bottom sets of pre-clipped shelf clips. Press each shelf downward so it is seated on each of the four clips. Repeat this procedure with the intermediate shelves.
4. When assembling back panels, slide one edge of the back panel between the inside flange of the angle post and the shelf, then slide the back between the post flange and shelf on the other side. Line up the holes in the back panel with holes in the post and bolt the back panel to the angle post using 1/4"-20 x 1/2" bolts and nuts using approximately the same spacing as used in bolting side panel to the post. Attach back to shelf clips as required to hold the back to the shelves.
5. If double row, assemble the front row as above - but do not bolt the back panel. Assemble the rear row the same as above, omitting the back panel. Push the units together and bolt through the two angle posts and the back panel using 1/4"-20 x 1/2" bolts and nuts at three places.



Accessories

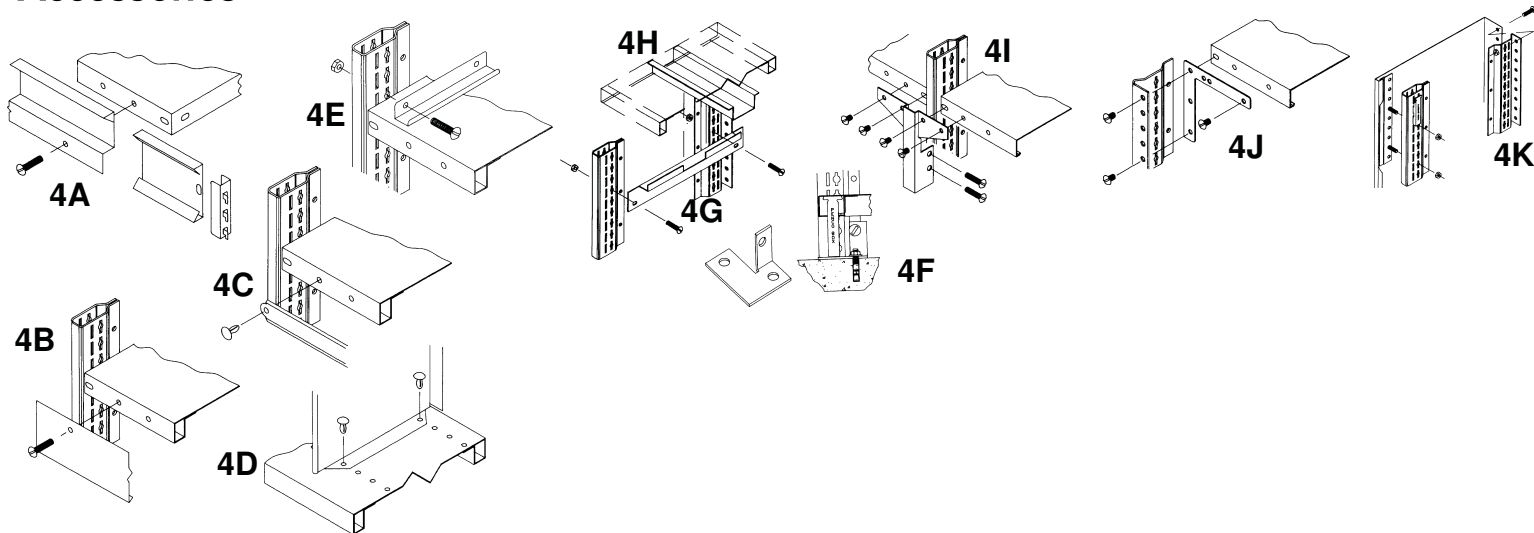

- 4A. Bin Fronts for box post.** – 1" and 2" high bin fronts attach to the front of the shelf with 1/4-20 x 1-1/4" bolts & nuts. 3" high will require bin front clips on each side. Seat clips into side slots of post and insert bin front.
- 4B. Front Base** – Fastens to bottom shelf with 1/4-20 x 1-1/4" bolts & nuts. When used with offset angle posts in the front, the ends of front base slide between the shelf and post.
- 4C. Label Holder** – Attaches to front flange of shelf with plastic button fasteners.
- 4D. Shelf Divider** – Assemble so bead is facing toward front. Engage plastic button fasteners through divider and shelf holes. Each fastener will serve for two dividers when arranged one directly above the other.
- 4E. Box Guide** – For use with optional shelf boxes. Attaches to front post only with 1/4-20 x 1-1/4" bolts and nuts. Two required per shelf.
- 4F. Floor Anchor Clip** – Fastens to the rear flange of posts with 1/4"-20 x 3/4" truss head bolts and hex nuts. If required bolt the vertical tab to each box post, or a single angle post or a double angle post.
- 4G. Side Shelf Support** – Bolts to the front and rear post with 5/16"-18 x 1-1/4" truss head bolts and hex nuts. Use two bolts and nuts per support. Assemble with the flange at the top of the support. Support Flange faces toward the inside of the unit.
- 4H Class 3 Shelf Support** – Place on the side shelf support under the shelf running left to right approx. midway front to rear with the flange ends against the bottom of the shelf. Place the shelf with the support on top of the side shelf support and en-gage the support in the side shelf support notch.
- 4I. Corner Angle Braces** – *For use with box posts and conventional flange shelves.* Place the brace over the box post and bolt with 5/16"-18 x 1-1/4" truss head bolt and finished hex nut. Bolt left and right flanges to respective shelves. Use two 1/4"-20 x 1/2" pan head machine screws and hex nuts per flange.
- 4J. Corner Angle Braces** – *For angle posts.* Place the brace between the angle post and the shelf. Bolt the brace to the post with two 1/4"-20 x 1/2" truss head bolts and hex nuts. Bolt to the shelf with one 1/4"-20 x 1/2" truss head bolts and hex nuts. For all bolts use the holes that align and are farthest from the brace corner.
- 4K. Finished End Panel** – All fasteners furnished are 1/4"-20 x 1-1/4" truss head bolts and nuts. Bolt the three "Z" shaped clips (Part No. 18100) to the body of the box post near the top & bottom and in the middle. Slip the return flange of the end panel under the "Z" clip and place the rear flange behind the post. Bolt the rear flange to the post near the top, bottom and middle.

