



## INCLUDED IN THIS MANUAL

General Information	2	Slide Door Receiver	17
Panels & Posts	3	Tunnel Door	18
Adjustable panels	4	Basic Ceiling	19
TES-4 & JSPE Detail	5	2" x 2" Horizontal Ceiling Tube	20
Hinge Door Hardware	6	2" x 4" Horizontal Ceiling Tube	21
Hinge Door Inside Swing	7	2" x 6" Horizontal Ceiling Tube	22
Hinge Door Outside Swing	8	Ceiling Tube Masonry Connections	23
Dutch Door	9	Physical Barrier	24
Double Hinge Door	10	Barrier Hinge Door Outside Swing	25
Slide Door Hardware	11	Barrier Hinge Door Inside Swing	26
Slide Door Outside	12-13	Rack Back®	27
Slide Door Inside	14-15	Rack Back® Hinge Door	28
Slide Door Panel Assembly	16	Component Location Work Sheet	29

# General Information

---

The following General Installation Instructions should be used as a guide for installing WireCrafters Style 840 Partitions. Because of the varying job site conditions, and infinite layout possibilities, there is no “recommended” way to install the product. **Good common sense and proper safety precautions must be used during installation.** The product may be unstable during installation; proper temporary bracing should be used until all hardware is tightened and the product is properly anchored to the floor. Permanent field bracing may be installed at installer’s/owner’s discretion. Install problems arising from job site conditions should be referred to a professional installer. Refer product assembly questions to WireCrafters.

## TOOLS RECOMMENDED

Chalk line & marker	Drill with adjustable clutch and 3/8” nut driver	(2) Step ladders if installing ceiling
Tape Measure	Hammer Drill with 3/8” masonry bit	(2) C clamps or Vise-Grip® type clamps
Level	(2) 9/16” open end wrenches and/or	#1 & #2 Phillips Screw Driver
Hacksaw	(2) 9/16” deep socket ratchets	1/2” deep socket or 1/2” open end wrench

## SELF DRILLING SCREW INSTALLATION RECOMMENDATIONS

When installing self drilling screws use a standard variable speed screw gun equipped with an adjustable clutch or depth locating nose piece. Take care not to over tighten or strip, set drill accordingly. **DO NOT USE IMPACT TYPE GUN WHEN INSTALLING SELF DRILLING SCREWS.** Securely clamp component parts in place before attaching with self drilling screws.

## INSTALLER TIPS

1. Installation is best accomplished with a two or three person crew.
2. Before starting, review all installation instructions pertinent to your layout (i.e. panels, doors, etc.)
3. “Face Side” of the partition is the outside, where nuts and bolts will NOT be visible or accessible. “Inside” of the partition has one leg of the panel frame pointing in. Assembly hardware will be on the inside of most layouts.
4. Panels install horizontally between posts, 2” mesh opening should be parallel with floor.
5. Identify all panels by part number. If possible stage parts where they will be installed.
6. Special size panels have metal tags on the mesh and are referenced on drawing.
7. Make sure all posts are installed plumb (vertically perpendicular to floor). Shims (not provided) may be necessary.
8. Use a 3-1/4” spacer block (not provided) to support far end of panel during setup.
9. Begin installation process at a building wall, end or corner of layout.
10. Gauge hinge door opening by width of transom panel.
11. Gauge slide door opening by door width (e.g. 48” between posts for 4’ wide slide door). When necessary, slide door openings may be narrowed to adjust length of adjacent run.
12. Standard hinge, double hinge, and slide doors are universal and may be installed inside or outside swing, left or right hand. Dutch and special doors are not universal and must be installed as shown out on drawing.
13. Installer should cut off any bolts or hardware protruding into aisle ways or around door openings.
14. Installer should touch up all nicks, marks, and scratches with touch up paint provided.



# Panels and Posts

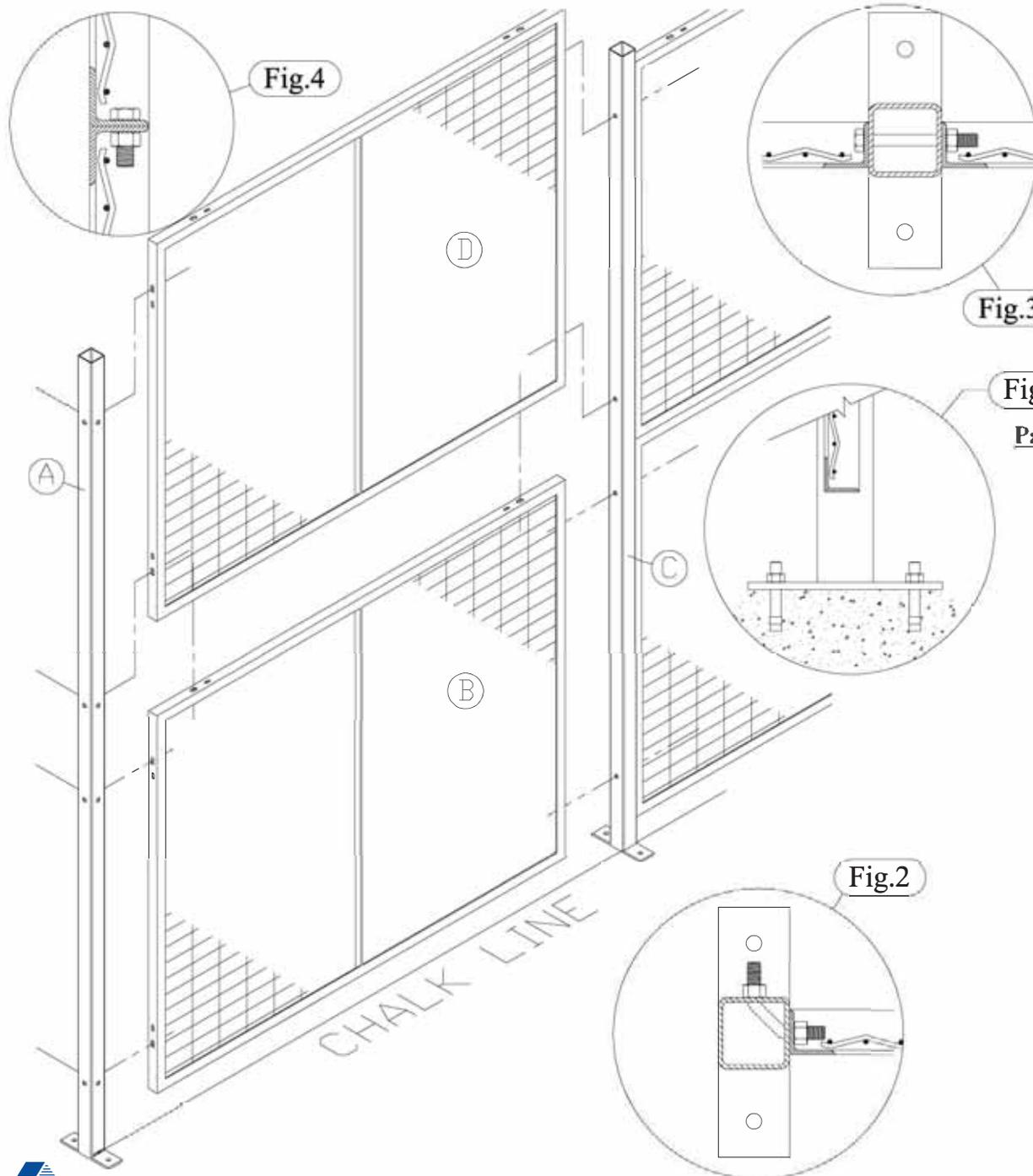

## INSTALLER NOTE

HACK SAW OFF  
AND DE-BURR ALL  
PROTRUDING THREADS

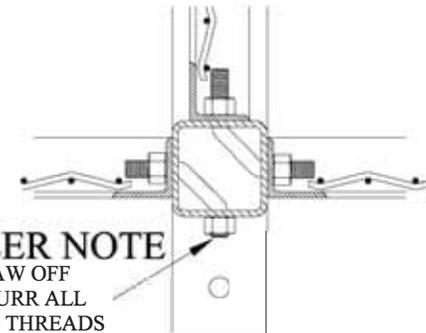

## TYPICAL TEE-POST CONNECTION

Fig.1

### Panels and Posts Installation

1. Use a chalk line to outline the partition layout on the floor.
  - a. ● out to out dimensions shown on drawing are to face side of posts.
  - b. Post base plates project 2-1/2" beyond outline of partition.
2. Lag end post (A) to floor per Fig. 1 using two anchors provided.
  - a. If end of partition mounts directly to building wall, support panel with 3-1/4" spacer block, and mount panel to wall with appropriate wall mount kit.
3. Mount bottom panel (B) to post (A)
  - a. Per Fig. 2 for corner post using two 3/8" corner bolts, or
  - b. Per Fig. 3 for run post using two 3/8" x 3" straight bolts, or
  - c. If mounting directly to building wall, skip this step.
  - d. **Note: Panels install horizontally; 2" mesh opening parallel with floor.**
4. Attach opposite end of panel (B) to second post (C)
  - a. per Fig.2 for corner post, or
  - b. Per Fig.3 for run post.
5. Lag post to floor using two anchors provided
6. Install top panel (D) between posts and bolt to lower panel (B) per Fig 4 using 3/8" x 1" nuts and bolts.



# Adjustable Panel Installation

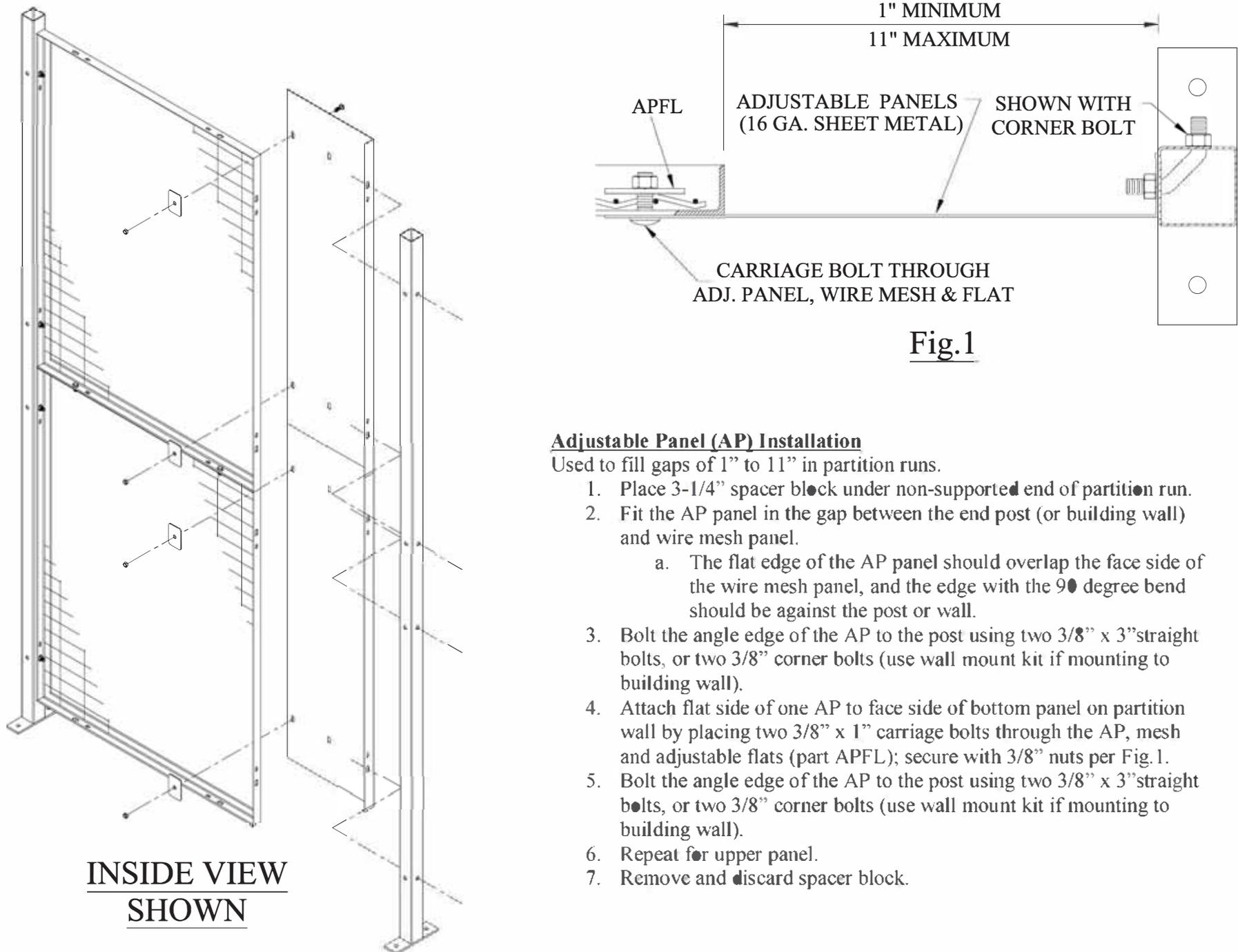

## Adjustable Panel (AP) Installation

Used to fill gaps of 1" to 11" in partition runs.

1. Place 3-1/4" spacer block under non-supported end of partition run.
2. Fit the AP panel in the gap between the end post (or building wall) and wire mesh panel.
  - a. The flat edge of the AP panel should overlap the face side of the wire mesh panel, and the edge with the 90 degree bend should be against the post or wall.
3. Bolt the angle edge of the AP to the post using two 3/8" x 3" straight bolts, or two 3/8" corner bolts (use wall mount kit if mounting to building wall).
4. Attach flat side of one AP to face side of bottom panel on partition wall by placing two 3/8" x 1" carriage bolts through the AP, mesh and adjustable flats (part APFL); secure with 3/8" nuts per Fig. 1.
5. Bolt the angle edge of the AP to the post using two 3/8" x 3" straight bolts, or two 3/8" corner bolts (use wall mount kit if mounting to building wall).
6. Repeat for upper panel.
7. Remove and discard spacer block.



# TES-4 & JSPE Details

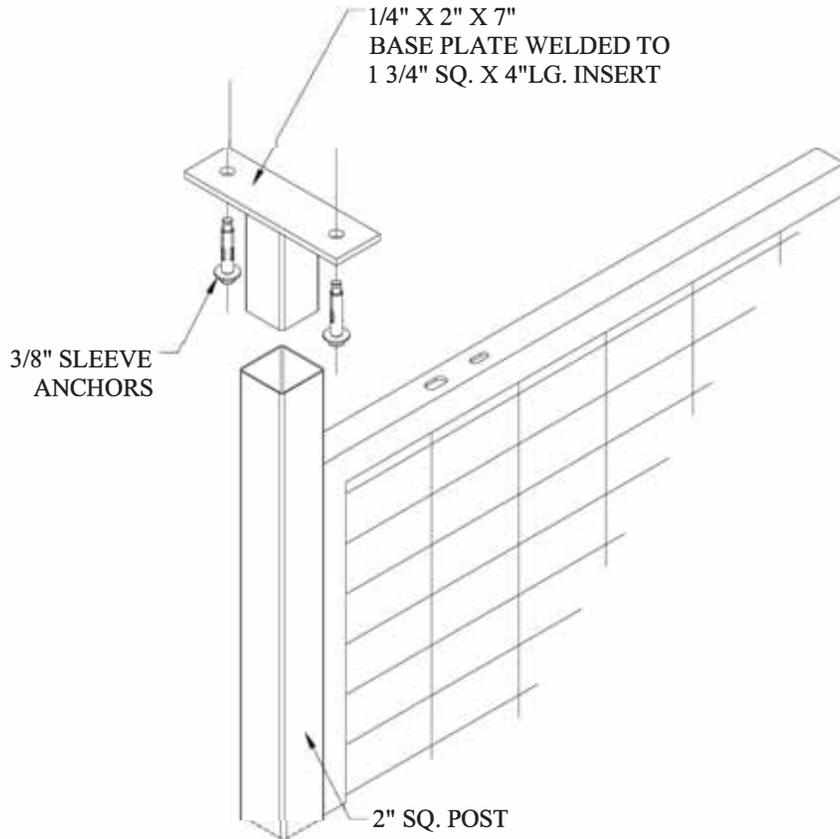

## DETAIL TES-4

Accessory item used to anchor  
partition wall to overhead structure.

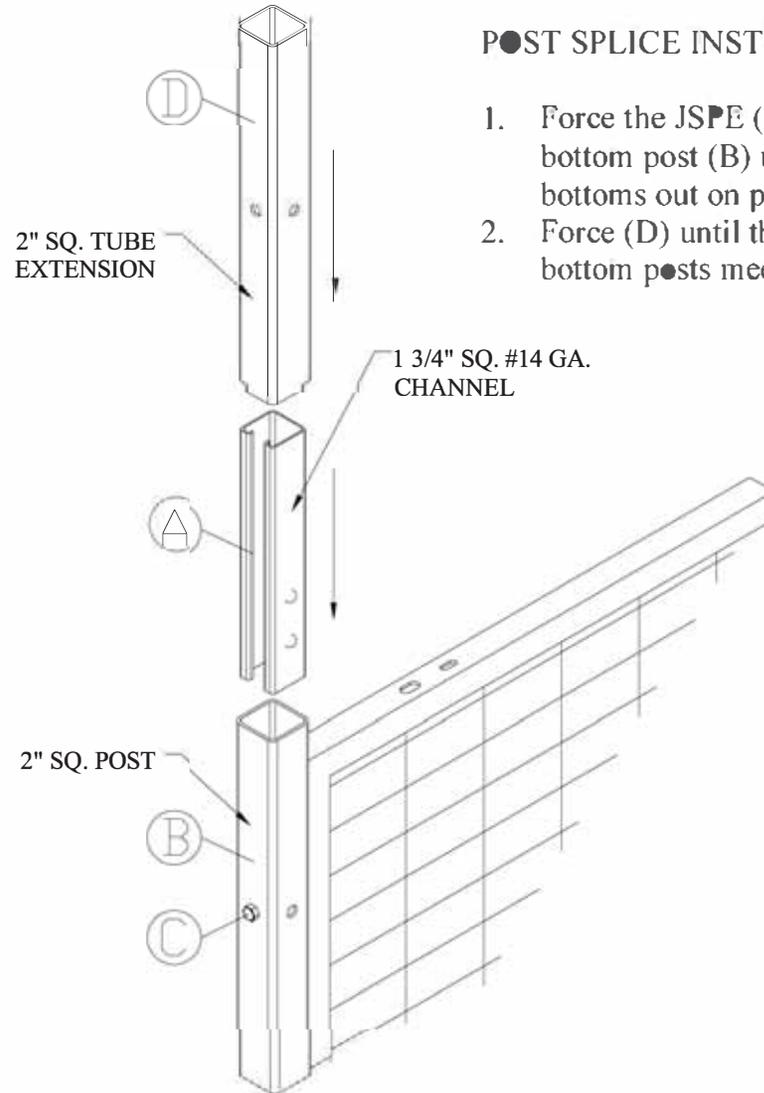

## POST SPLICE INSTRUCTIONS

1. Force the JSPE (A) into the bottom post (B) until it bottoms out on panel bolt (C).
2. Force (D) until the top and bottom posts meet flush.

## DETAIL JSPE

Accessory item used to extend  
height of existing wall.



# Hinge Door Hardware Pack

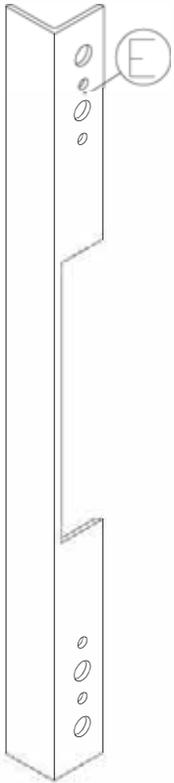

Hinge Door Angle Pick Plate  
Quantity (1)  
Part# HDCPLI

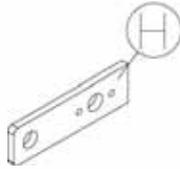

Hinge Door Flat Padlock Lug  
Quantity (1)  
Part# HDFLPLLI

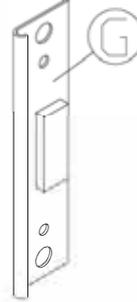

Hinge Door Lock Receiver  
Quantity (1)  
Part# HDLRLI

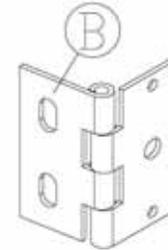

Door Hinge  
Quantity (3)  
Part# HDHG44I

**SEE SUPPLIED LOCK MANUFACTURER  
INSTRUCTIONS FOR ASSEMBLY**

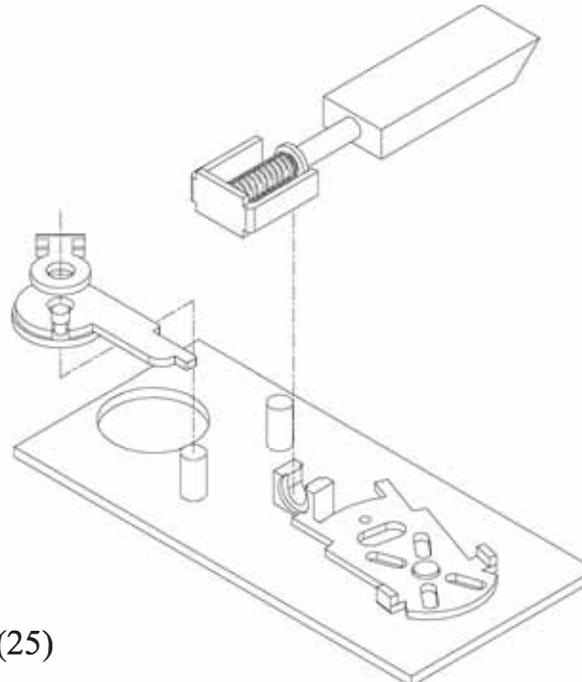

RIGHT HAND ASSEMBLY

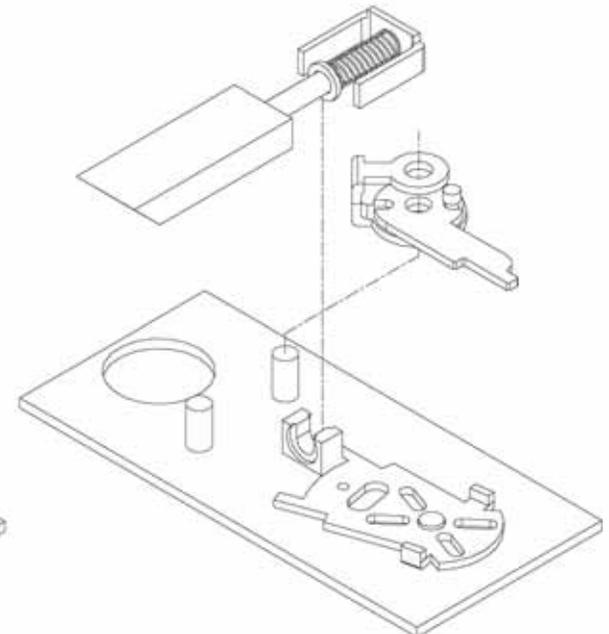

LEFT HAND ASSEMBLY

- HDFSPK - Fastener Pack (Contents Below)
- (25) FSHOPG- Gray Hole Plugs
  - (8) COBO- 3/8" Corner Bolts
  - (8) FS383- 3/8" x 3" Hex Head Cap Screw
  - (6) FS381- 3/8" x 1" Hex Head Cap Screw
  - (30) FS38N- 3/8" Hex Nut
  - (4) FS38STA- 3/8" Wedge Anchor
  - (1) FSTRNSPK- 1/4" x 1" Self-Drilling Screws (25)



# Hinge Door Inside Swing Right Hand Shown

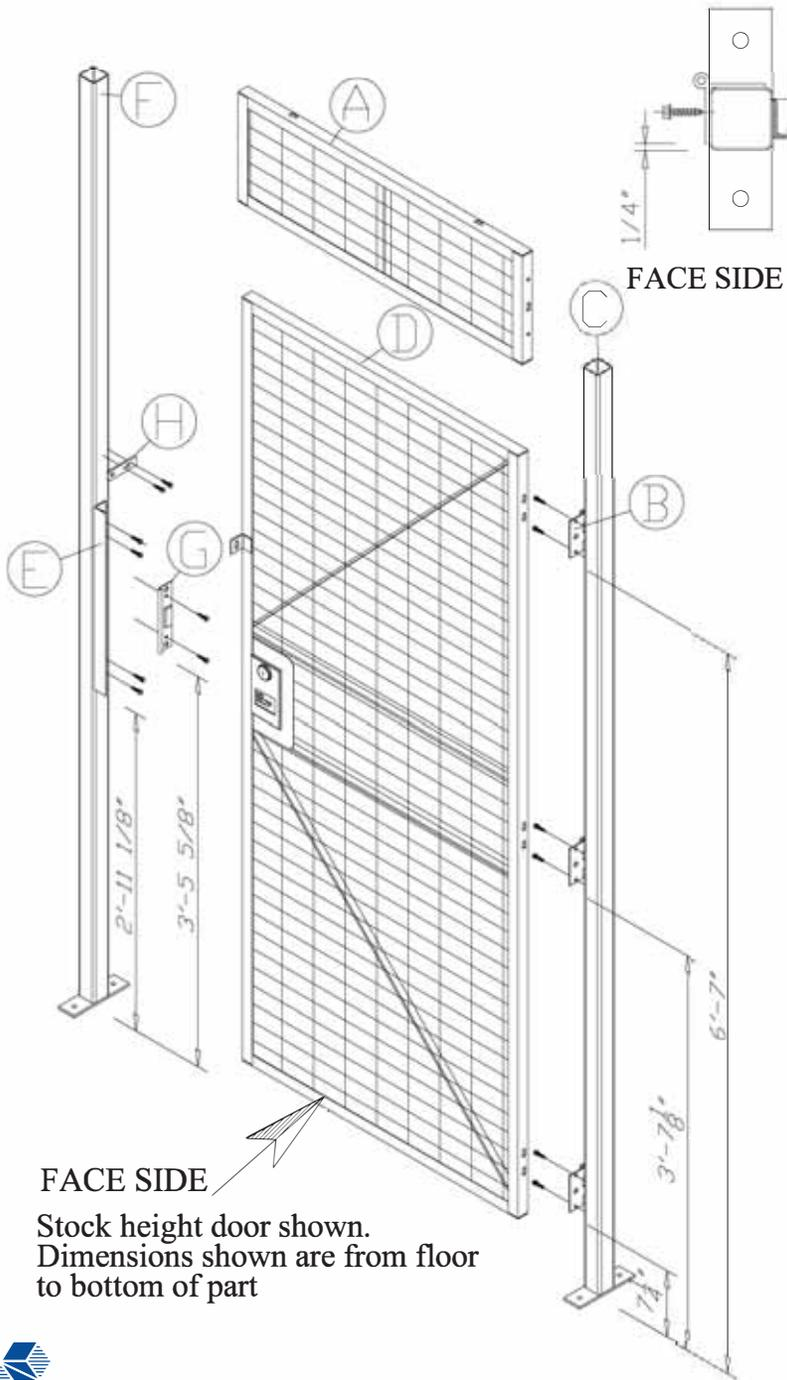

FACE SIDE  
Stock height door shown.  
Dimensions shown are from floor  
to bottom of part

**Fig.2**

**INSTALLATION TIP:**  
When attaching hinge to door  
post wrap hinge around post  
(as shown in drawing) to set  
proper offset alignment

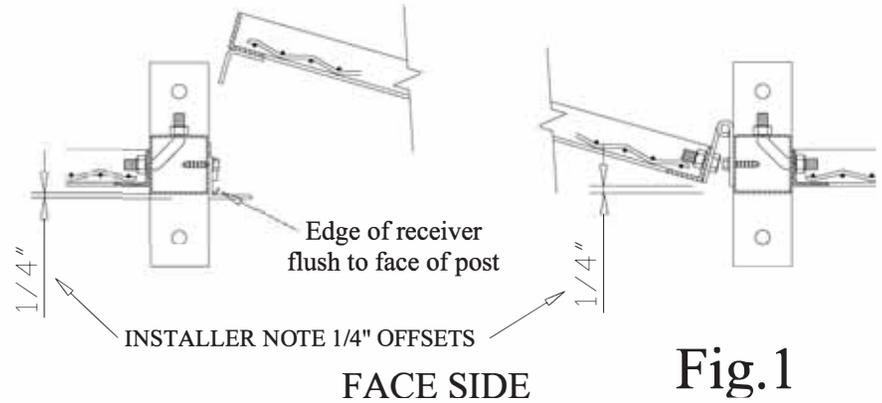

**Fig.1**

**INSTALLER NOTES:**

1. Component parts attach using self-drilling screws. Use variable speed screw gun with adjustable clutch or depth locating nose piece. Use care not to over tighten and strip threads. **DO NOT USE IMPACT TYPE GUNS.** Securely clamp part in place before attaching with self drilling screws.
2. The dimensions shown on this page are from the floor to the bottom of the part for standard height 6' 11-3/4" door opening with 3-1/4" sweep space. Use worksheet on page 29 to calculate component locations for non-standard door opening heights or sweep spaces.
3. Partition wall should be set up and anchored to floor, with posts plumb, before attempting to install doors.

**Hinge Door Inside Swing**

1. Install transom panel (A) at top of door opening, check opening width at floor, and anchor posts to floor. Check that posts are plumb and opening is square.
2. Attach hinges (B) to door post (C) using two self drilling screws per hinge.
  - a. Note hinge placement offset detailed in Fig.1 and install tip in Fig.2.
  - b. If necessary, remove lower two 3/8" x 3" panel mounting bolts, and replace with corner bolts.
  - c. Stock Doors (3-1/4" sweep sp.), place bottom of hinge 7-1/4", 43 1/8", and 79" from floor.
  - d. Cut off and file smooth any protruding bolt threads.
3. Attach door panel (D) to hinges with two 3/8" x 1" bolts and nuts.
  - a. Set desired sweep space (3-1/4" for stock doors).
4. Attach pick plate (E) to door post (F) using four self drilling screws.
  - a. Note pick plate position offset detailed in Fig 1.
  - b. Bottom of pick plate installs 35-1/8" from floor for stock doors.
  - c. If necessary, remove two 3/8" x 3" panel mounting bolts and replace with corner bolts. Cut off and file smooth any protruding bolt threads.
5. Install cylinder lock (if applicable). See page 6.
6. Attach cylinder lock receiver (G) to door post (F) with two self-drilling screws.
  - a. Rolled side of receiver installs to face side of partition.
  - b. Bottom of receiver installs 41-5/8" from floor for stock doors.
7. Align padlock lug (H) with door padlock lug on door (D) and attach to post (F) with two self drilling screws.
8. Check operation of door, adjust as needed.



# Hinge Door Outside Swing Right Hand Shown

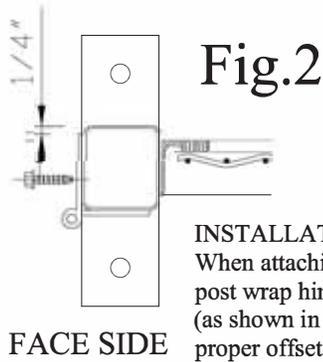

**INSTALLATION TIP:**  
When attaching hinge to door post wrap hinge around post (as shown in drawing) to set proper offset alignment

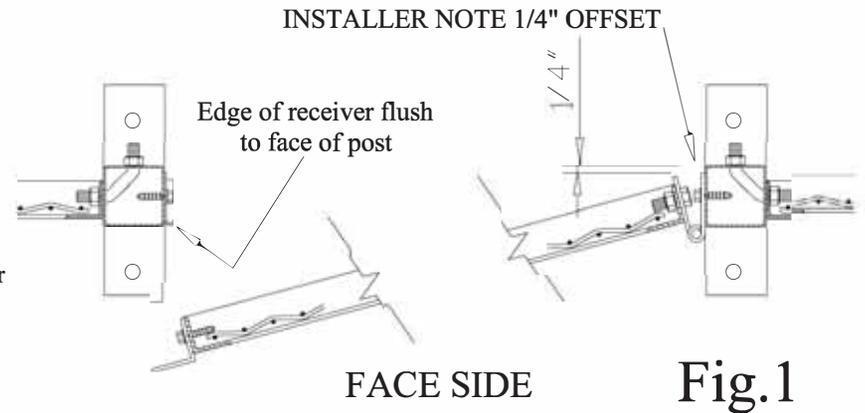

## INSTALLER NOTES:

1. Component parts attach using self-drilling screws. Use variable speed screw gun with adjustable clutch or depth locating nose piece. Use care not to over tighten and strip threads. **DO NOT USE IMPACT TYPE GUNS**. Securely clamp part in place before attaching with self drilling screws.
2. The dimensions shown on this page are from the floor to the bottom of the part for standard height 6' 11-3/4" door opening with 3-1/4" sweep space. Use worksheet on page 29 to calculate component locations for non-standard door opening heights or sweep spaces.
3. Partition wall should be set up and anchored to floor, with posts plumb before attempting to install doors.

## Hinge Door Outside Swing

1. Install transom panel (A) at top of door opening, check opening width at floor, and anchor posts to floor. Check that posts are plumb and opening is square.
2. Attach hinges (B) to door post (C) using two self drilling screws per hinge.
  - a. Note hinge placement offset detailed in Fig 1 and install tip in Fig. 2.
  - b. If necessary remove lower two 3/8" x 3" panel mounting bolts and replace with corner bolts.
  - c. Cut off and file smooth any protruding bolt threads.
  - d. Stock doors (3-1/4" sweep sp.), place bottom of hinge 7-1/4", 43-1/8", and 79" from floor.
3. Attach door panel (D) to hinges with two 3/8" x 1" bolts and nuts.
  - a. Set desired sweep space (3-1/4" for stock doors).
4. Attach pick plate (E) to door panel (D) using four self drilling screws. See Fig. 1.
  - a. Pick plate should be centered over lock tongue hole. Bottom of pick plate installs 31-7/8" from bottom of stock doors.
5. Install cylinder lock (if applicable). See page 6.
6. Attach cylinder lock receiver (G) to door post (F) with two self-drilling screws.
  - a. Rolled side of receiver installs to face side of partition.
  - b. Bottom of receiver installs 41-5/8" from floor for stock doors.
  - c. If necessary remove one 3/8" x 3" panel mounting bolts from top of lower panel, and replace with corner bolt. Cut off and file smooth any protruding bolt threads.
7. Align padlock lug (H) with door padlock lug on door (D) and attach to post (F) with two self drilling screws.
8. Check operation of door, adjust as needed.

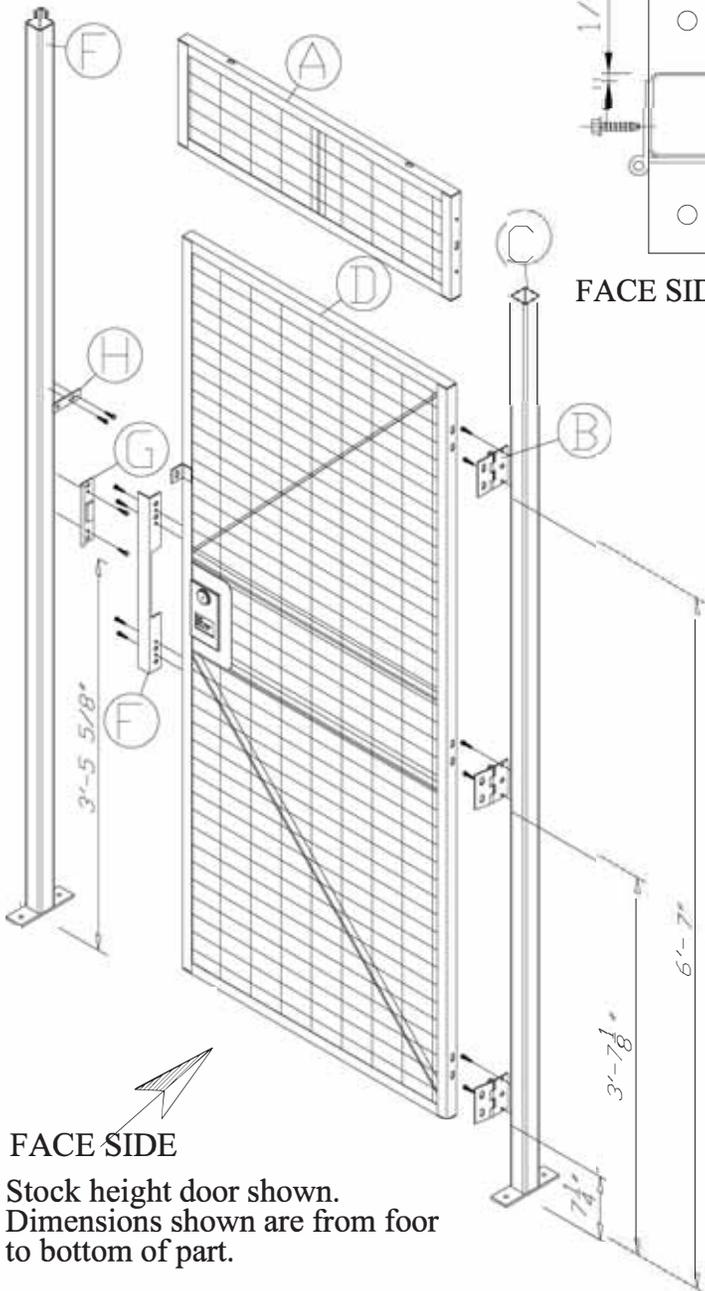

# Dutch Door Outside Swing Right Hand Shown

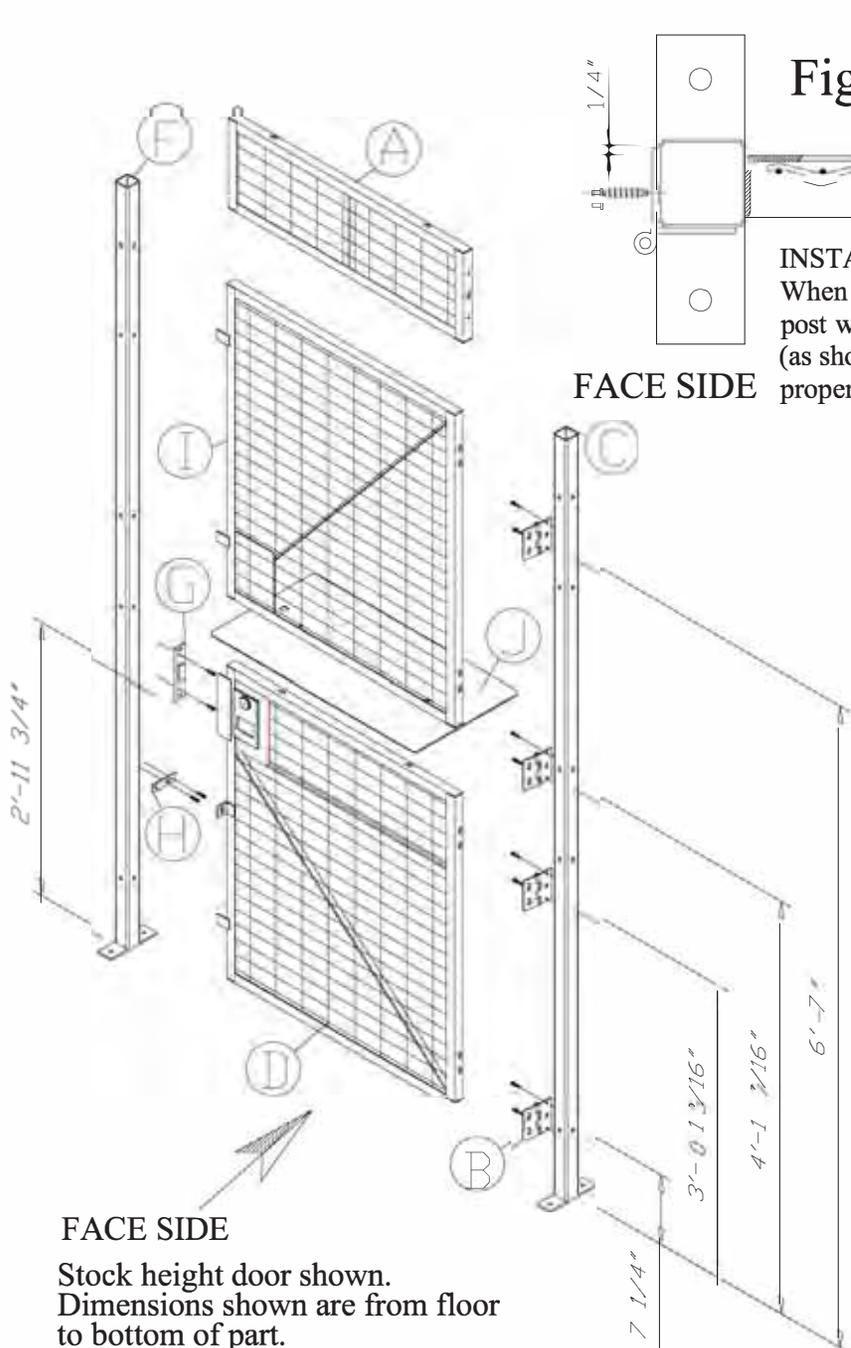

FACE SIDE

Stock height door shown.  
Dimensions shown are from floor  
to bottom of part.

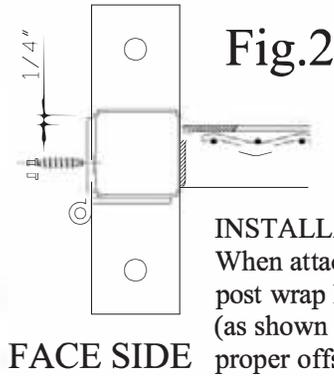

Fig.2

**INSTALLATION TIP:**  
When attaching hinge to door  
post wrap hinge around post  
(as shown in drawing) to set  
proper offset alignment

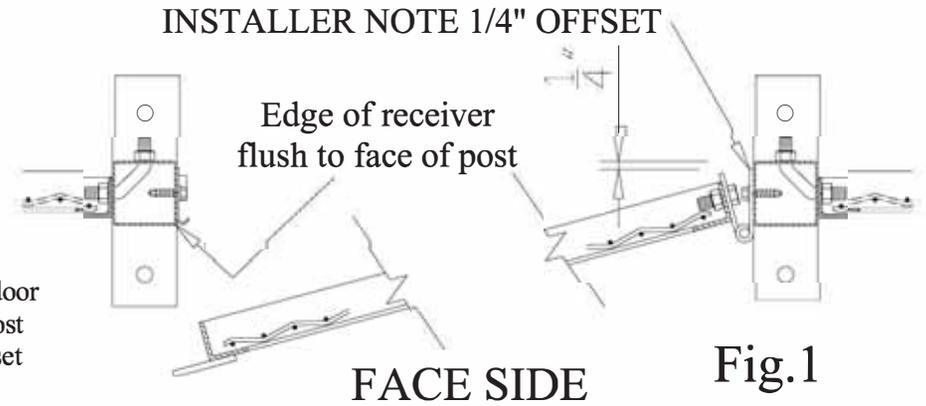

Fig.1

**INSTALLER NOTES:**

1. Component parts attach using self-drilling screws. Use variable speed screw gun with adjustable clutch or depth locating nose piece. Use care not to over tighten and strip threads. **DO NOT USE IMPACT TYPE GUNS.** Securely clamp part in place before attaching with self drilling screws.
2. The dimensions shown on this page are from the floor to the bottom of the part for standard height 6' 11-3/4" door opening with 3-1/4" sweep space. Use worksheet on page 29 to calculate component locations for non-standard door opening heights or sweep spaces.
3. Partition wall should be set up and anchored to floor, with posts plumb before attempting to install doors.

**Dutch Door Outside Swing**

1. Install transom panel (A) at top of door opening, check opening width at floor, and anchor posts to floor. Check that posts are plumb and opening is square.
2. Attach hinges (B) to door post (C) using two self drilling screws per hinge. Note offset detailed in Fig.1 and install tip Fig.2.
  - a. Stock door (3-1/4" sweep sp.), locate bottom of hinge 7-1/4", 36-13/16", 49-7/16" and 79" from floor. If necessary remove 3/8" x 3" panel mount bolt and replace with corner bolt, cut off and file smooth any protruding bolt threads.
3. Attach door panels (D) & (I) to hinges with two 3/8" x 1" bolts per hinge,
  - a. Set sweep space under lower door panel (3-1/4" for stock doors).
  - b. Set 5/8" gap between door panels.
4. Install cylinder lock (if applicable). See page 6.
5. Attach receiver (G) to door post (F) using two self drilling screws.
  - a. Rolled side of receiver installs to face side of partition.
  - b. Bottom of receiver installs 35-3/4" from floor for stock doors.
  - c. If necessary, remove one 3/8" x 3" panel mounting bolt from top of lower panel and replace with corner bolt.
  - d. Cut off and file smooth any protruding bolt threads.
6. Align padlock lug (H) with padlock lug on door (D) and attach to post (F) with self drilling screws.
7. Attach shelf (J) to top of door panel (D) with two 3/8" x 1" carriage bolts.
8. Check operation of door, adjust as needed.



# Double Hinge Door

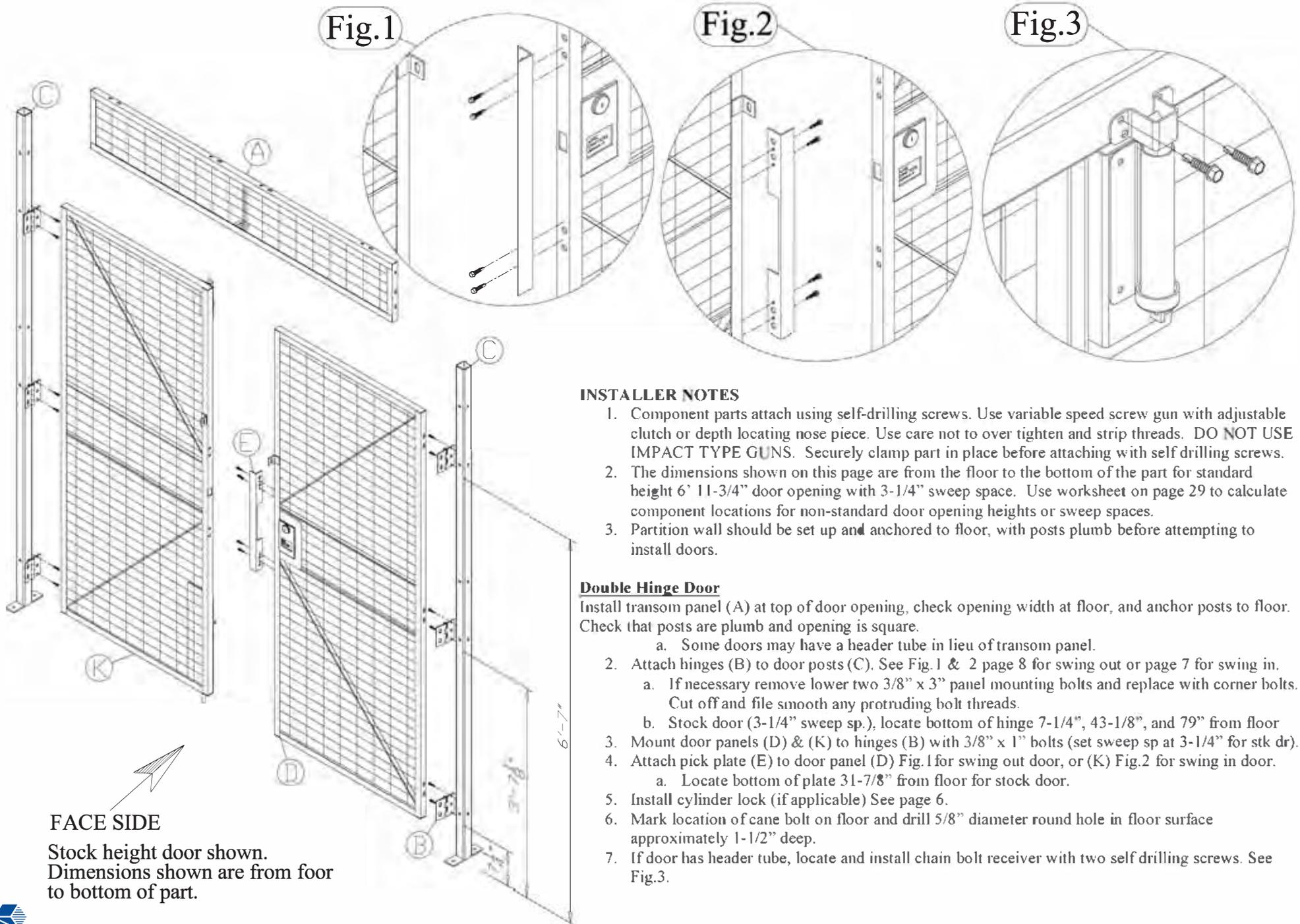

FACE SIDE

Stock height door shown.  
Dimensions shown are from floor  
to bottom of part.

Fig.1

Fig.2

Fig.3

## INSTALLER NOTES

- Component parts attach using self-drilling screws. Use variable speed screw gun with adjustable clutch or depth locating nose piece. Use care not to over tighten and strip threads. **DO NOT USE IMPACT TYPE GUNS.** Securely clamp part in place before attaching with self drilling screws.
- The dimensions shown on this page are from the floor to the bottom of the part for standard height 6' 11-3/4" door opening with 3-1/4" sweep space. Use worksheet on page 29 to calculate component locations for non-standard door opening heights or sweep spaces.
- Partition wall should be set up and anchored to floor, with posts plumb before attempting to install doors.

## Double Hinge Door

Install transom panel (A) at top of door opening, check opening width at floor, and anchor posts to floor. Check that posts are plumb and opening is square.

- Some doors may have a header tube in lieu of transom panel.
- Attach hinges (B) to door posts (C). See Fig. 1 & 2 page 8 for swing out or page 7 for swing in.
    - If necessary remove lower two 3/8" x 3" panel mounting bolts and replace with corner bolts. Cut off and file smooth any protruding bolt threads.
    - Stock door (3-1/4" sweep sp.), locate bottom of hinge 7-1/4", 43-1/8", and 79" from floor
  - Mount door panels (D) & (K) to hinges (B) with 3/8" x 1" bolts (set sweep sp at 3-1/4" for stk dr).
  - Attach pick plate (E) to door panel (D) Fig. 1 for swing out door, or (K) Fig. 2 for swing in door.
    - Locate bottom of plate 31-7/8" from floor for stock door.
  - Install cylinder lock (if applicable) See page 6.
  - Mark location of cane bolt on floor and drill 5/8" diameter round hole in floor surface approximately 1-1/2" deep.
  - If door has header tube, locate and install chain bolt receiver with two self drilling screws. See Fig. 3.

# Slide Door Hardware Pack

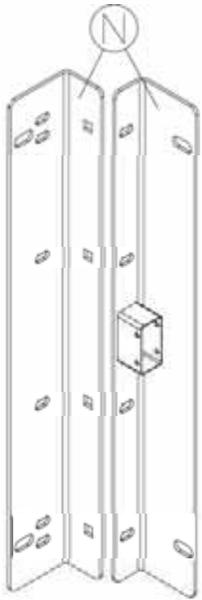

SDRECA SDRECB  
Slide Door Receiver  
Quantity (1)  
Part# SDLKRECA&B

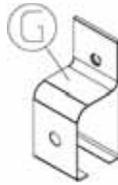

Slide Door Track Bracket  
Quantity (2)  
Part# SDTCBKT



4 Wheel Trolley Truck  
Quantity (2)  
Part# SDTT4WH

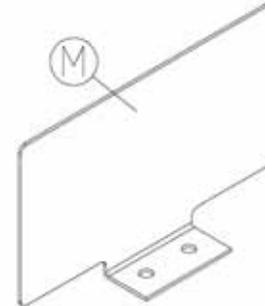

Door Guide  
Quantity (1)  
Part# SDDGCH18



1 11/16" x 1 1/2" Channel 4" Lg.  
Quantity (1)  
Part# SDSDT

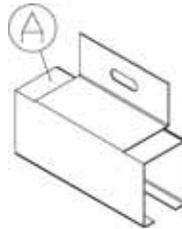

Splice Track Bracket  
Quantity (1)  
Part# SDTJBKT

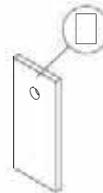

Slide Door Shim  
Quantity (4)  
Part# SDSCH412238

**SEE SUPPLIED LOCK**  
**MANUFACTURER INSTRUCTIONS FOR**  
**ASSEMBLY**

**SDFSPK - Slide Door Fastener Pack (Contents Below)**

- (35) FSHOPG- Gray Hole Plugs
- (2) COBO- 3/8" Corner Bolts
- (9) FS383- 3/8" x 3" Hex Head Cap Screw
- (2) FS381- 3/8" x 1" Hex Head Cap Screw
- (17) FS38N- 3/8" Hex Nut
- (6) FS38STA- 3/8" Wedge Anchor
- (6) FS38FW- 3/8" Flat Washer
- (1) FS38112- 3/8" x 1 1/2" Hex Head Cap Screw
- (1) FS38212- 3/8" x 2 1/2" Hex Head Cap Screw
- (2) SDLKSPPN- Slide Door Receiver Pins
- (1) FSTRNSPK- 1/4" x 1" Self-Drilling Screws (25) & 5/16" X 1" Carriage Bolts (4)

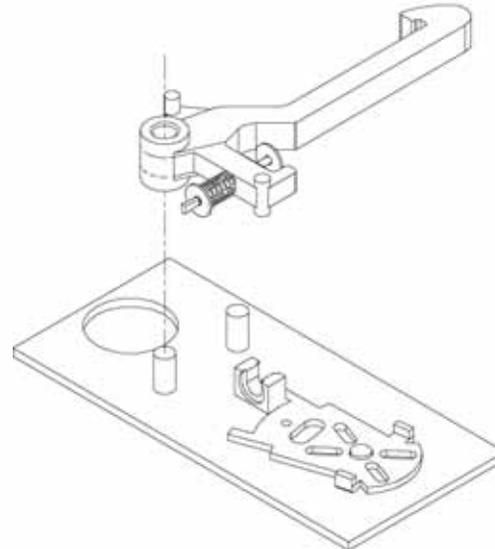

**RIGHT HAND ASSEMBLY**

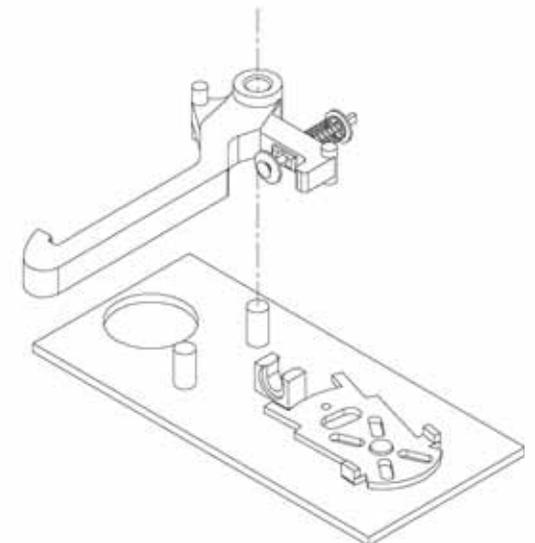

**LEFT HAND ASSEMBLY**



# Outside Slide Door

---

## INSTALLER NOTES

1. Doors wider than 5' are made up of multiple door panels (see page 16), and use two pieces of track spliced at Splice Track Bracket (A).
2. Component parts attach using self-drilling screws. Use variable speed screw gun with adjustable clutch or depth locating nose piece. Use care not to over tighten and strip threads. **DO NOT USE IMPACT TYPE GUNS.** Securely clamp part in place before attaching with self drilling screws.
3. Partition wall should be set up and anchored to floor. It is **CRITICAL** that posts are plumb and in line. Door opening should be square.

## Outside Slide Door

1. Check that door posts are anchored and plumb.
2. Using a 3/8" x 3" bolt, install Splice Track Bracket (A) on face side of door post (B) opposite door receiver post (C). Note: if enclosure has ceiling use a 3/8" x 1" bolt to attach bracket see Fig.1.
3. Place two 4 wheel trolley trucks (F) into track (D). Using one 3/8" x 1" bolt, attach track bracket (G-1) to track.
  - a. Check that trucks roll freely in track.
4. Slide open end of track (D) into Splice Track Bracket (A). Using one 3/8" x 3" bolt, attach track bracket (G-1) to receiver post (C) see Fig 2.
5. Invert Track Bracket (G-2) and attach to far end of Track (D) using one 3/8" x 1" bolt. If end of track aligns with post, do not invert track bracket.
  - a. For doors wider than 5'
    - i. Attach inverted bracket to far end of second track section.
    - ii. Slide open end of second track section (D) into open end of Splice Track Bracket (A).
6. Using one 3/8" x 1-1/2" bolt and two Slide Door Shims, attach the inverted track bracket on the far end of Track (D) to the wire mesh panel.
  - a. Per Fig. 3 place one flat Slide Door Shim between the Track Bracket (G-2) and the mesh, and the other Slide Door Shim on the inside of the mesh and fasten in place with one 3/8" x 1-1/2" bolt and hex nut. **TRACK MUST BE LEVEL.**
  - b. Should Track Bracket (G-2) align with post, attach upright track bracket to post with 3/8" bolt.
7. For doors wider than 5' or taller than 8', assemble door panels to form door assembly. See Slide Door Panel Assembly page 16.
8. Hang door (I) on Trolley Trucks.
  - a. Two 9/16" round holes on top of door assembly match trolley bolts.
  - b. Trolley bolts should have one nut above and below door frame; upper "jam" nut should be backed off until door operation is finalized.
9. Raise door to desired sweep space using lower trolley nut.
  - a. Stock doors without lower angle cover bar have 3-1/4" sweep space.
  - b. Stock doors with lower angle cover bar have 1-3/4" sweep space.
  - c. Door must be level for proper operation.
10. Lag Door Guide (M) to floor with two floor anchors see Fig 4.
11. Door should slide freely, if not check that trolley trucks are properly aligned in track.
12. If applicable, install cylinder lock in door, see page 11.
13. Install Lock Receiver (N). See Fig 5. and slide door receiver instructions on page 17.
14. Fine tune door by tightening/loosening trolley truck nuts.
  - a. When door operates smoothly and locks consistently, tighten top jam nut.
  - b. Be sure not to cock trolleys sideways when tightening jam nut. It may be necessary to hold bolt with pliers while tightening jam nut.



# Outside Slide Door

NOTE: 10' High Doors, See Page 16

Fig.1

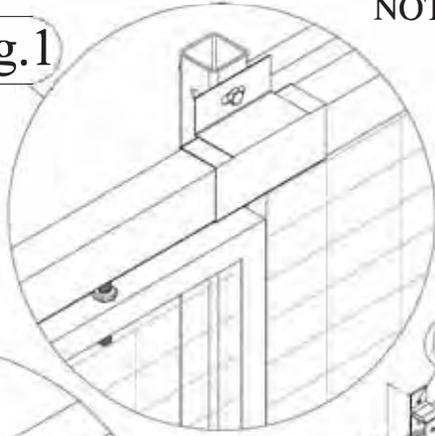

PARTIAL MESH SHOWN FOR CLARITY

Fig.2

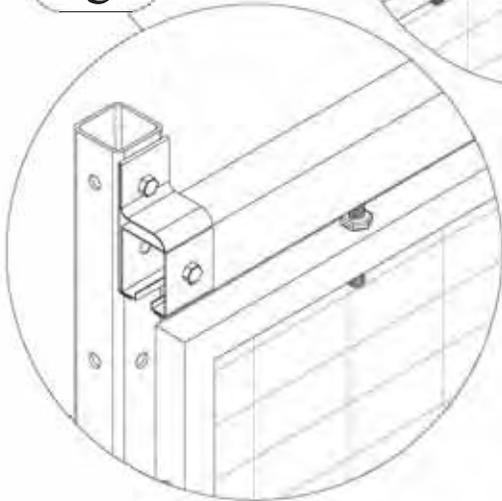

Fig.3

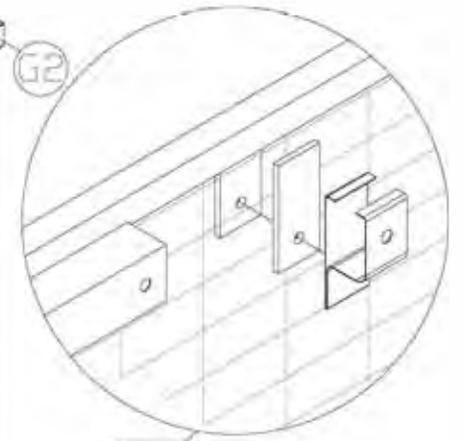
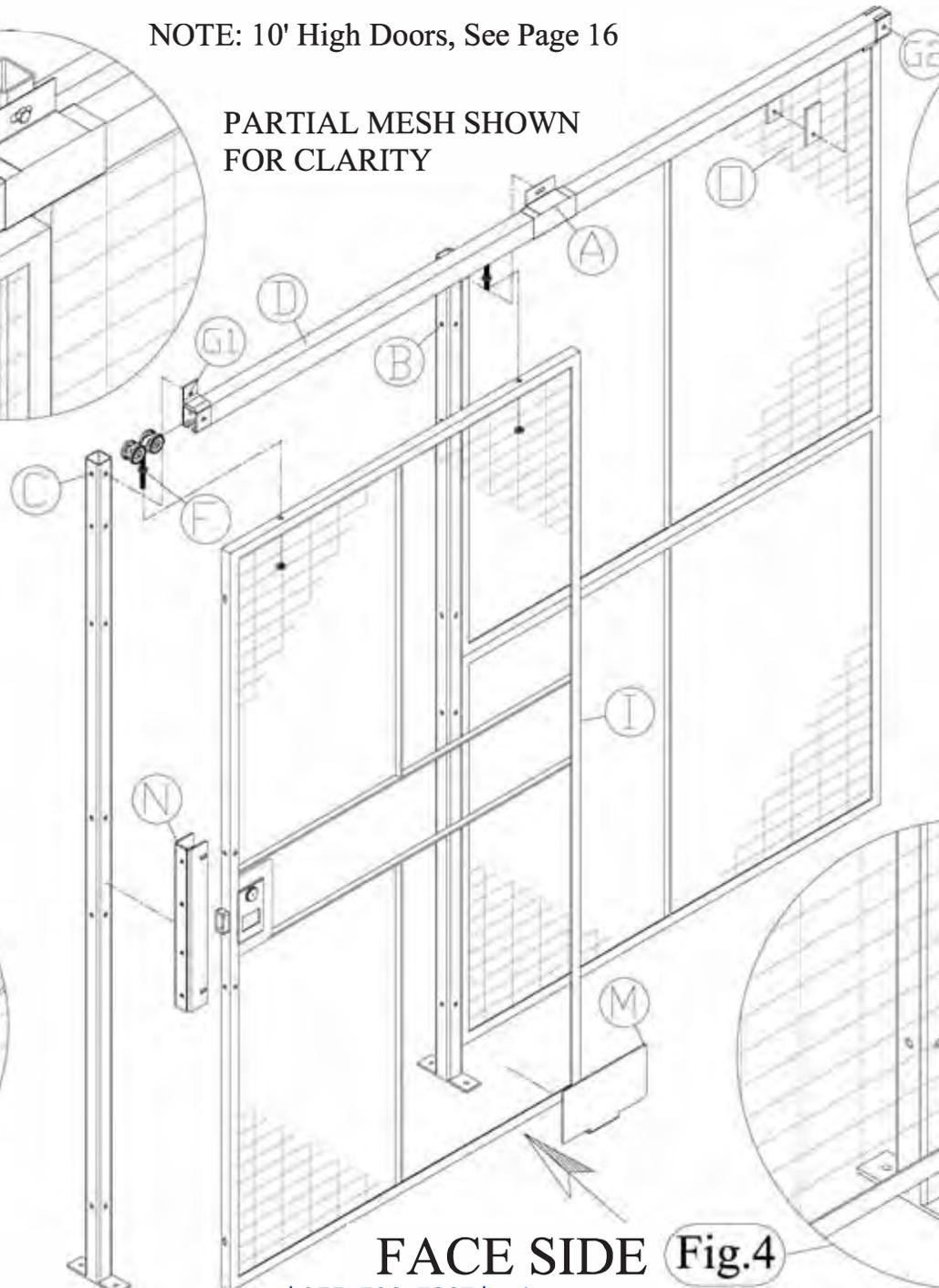
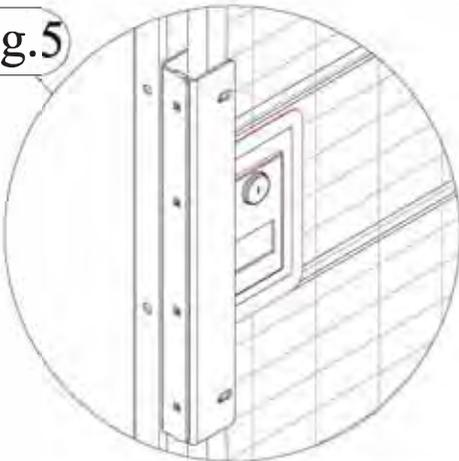
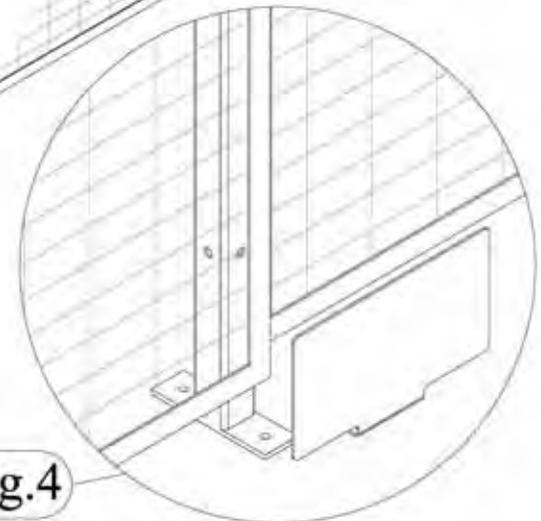

Fig.5



FACE SIDE Fig.4



# Inside Slide Door

---

## INSTALLER NOTES

1. Doors wider than 5' are made up of multiple door panels (see page 16), and use two pieces of track spliced at Track Bracket (A).
2. Component parts attach using self-drilling screws. Use variable speed screw gun with adjustable clutch or depth locating nose piece. Use care not to over tighten and strip threads. **DO NOT USE IMPACT TYPE GUNS.** Securely clamp part in place before attaching with self drilling screws.
3. Partition wall should be set up and anchored to floor. It is **CRITICAL** that posts are plumb and in line. Door opening should be square.

## Inside Slide Door

1. Check that door posts are anchored and plumb.
2. Using a 3/8" x 3" bolt and one Slide Door Shim(O), install Splice Track Bracket (A) on inside of door post (B) opposite door receiver post (C). Place the shim between the bracket and the post. Note: If enclosure has ceiling, use a 3/8" x 1" bolt to attach bracket see Fig.1.
3. Place two 4 wheel trolley trucks (F) into track (D). Using one 3/8" x 1" bolt attach track bracket (G1) to track.
  - a. Check that trucks roll freely in track.
4. Slide open end of track (D) into Splice Track Bracket (A). Using one 3/8" x 3" bolt and one Slide Door Shim (O), attach track bracket (G1) to inside of receiver post (C) see Fig 2.
5. Invert Track Bracket (G2) and attach to far end of Track (D) using one 3/8" x 1" bolt. If end of track aligns with post, do not invert track bracket.
  - a. For doors wider than 5'
    - i. Attach inverted bracket to far end of second track section.
    - ii. Slide open end of second track section (D) into open end of Splice Track Bracket (A).
6. Using one 3/8" x 2-1/2" bolt, one Slide Door Shim and one 2" Slide Door Spacer (P), attach the inverted track bracket on the far end of Track (D) to the wire mesh panel. **TRACK MUST BE LEVEL.**
  - a. Per Fig. 3 place one 2" Slide Door Spacer between the Track Bracket and the mesh, and the Slide Door Shim on the outside of the mesh and fasten in place with one 3/8" x 2-1/2" bolt and hex nut.
  - b. Should Track Bracket (G-2) align with post, attach upright track bracket to post with 3/8" bolt.
7. For doors wider than 5' or taller than 8', assemble door panels to form door assembly. See Slide Door Panel Assembly page 16.
8. Hang door (I) on Trolley Trucks.
  - a. Two 9/16" round holes on top of door assembly match trolley bolts.
  - b. Trolley bolts should have one nut above and below door frame; upper "jam" nut should be backed off until door operation is finalized.
9. Raise door to desired sweep space using lower trolley nut.
  - a. Stock doors without lower angle cover bar have 3-1/4" sweep space.
  - b. Stock doors with lower angle cover bar have 1-3/4" sweep space.
  - c. Door must be level for proper operation.
10. Lag Door Guide (M) to floor with two floor anchors see Fig.4.
11. Door should slide freely. If not check that trolley trucks are properly aligned in track.
12. If applicable, install cylinder lock in door, see page 11.
13. Install Lock Receiver (N). See Fig.5 and Slide Door Receiver instruction on page 17.
14. Fine tune door by tightening/loosening trolley truck nuts.
  - a. When door operates smoothly and locks consistently, tighten top jam nut.
  - b. Be sure not to cock trolleys sideways when tightening jam nut. It may be necessary to hold bolt with pliers while tightening jam nut.



# Inside Slide Door

NOTE: 10' High Doors, See Page 16

PARTIAL MESH SHOWN  
FOR CLARITY

Fig.1

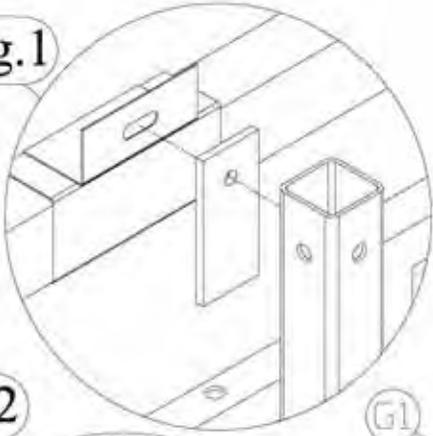

Fig.2

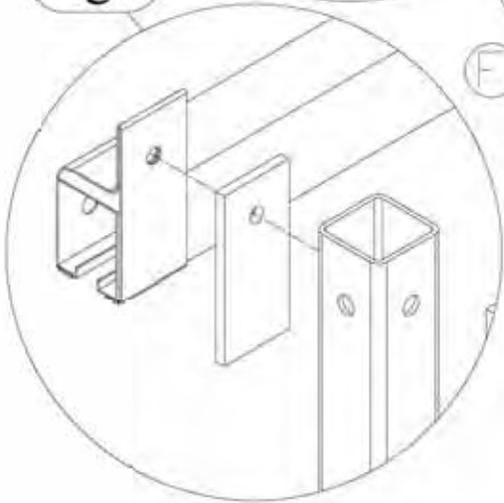

Fig.5

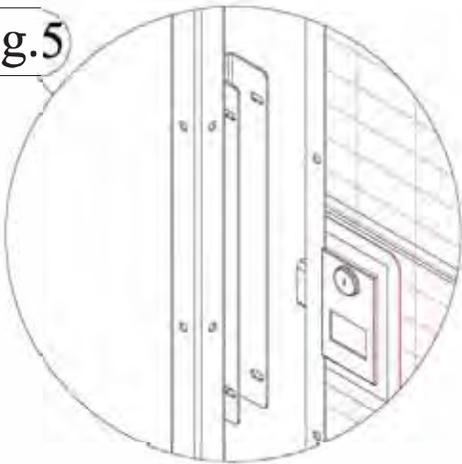

Fig.3

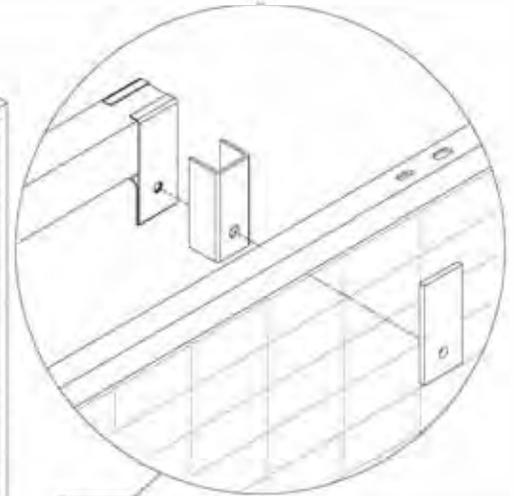
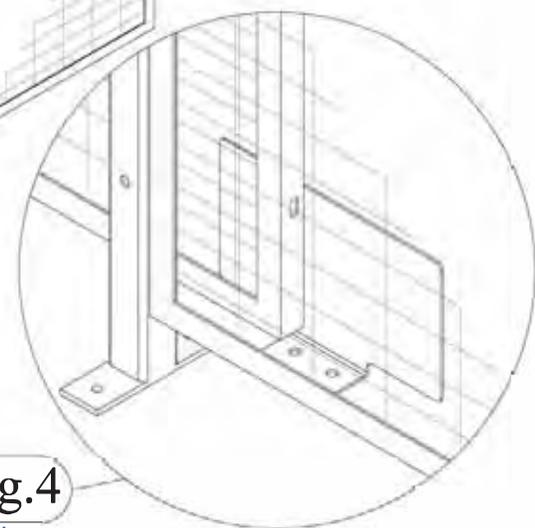

Fig.4



FACE SIDE



# 6' or Wider Slide Door Panel Assembly

NOTE: Part (C) DEP for 10'  
High Doors Only

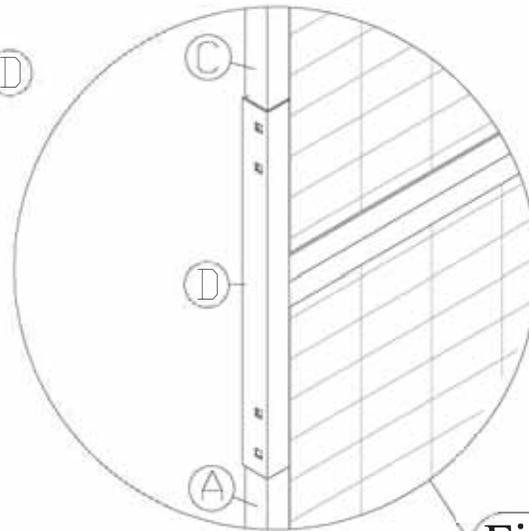
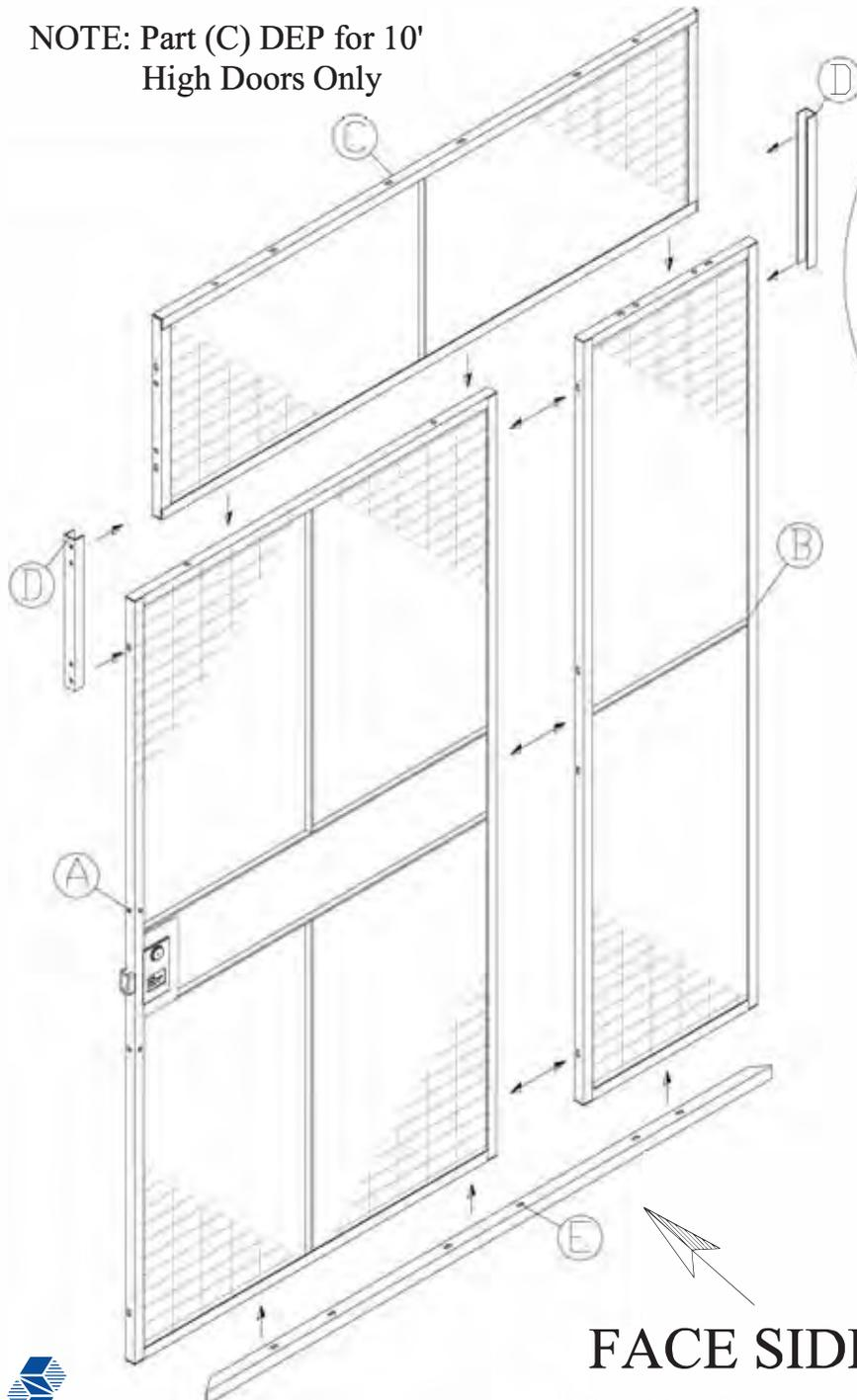

10' High Doors or Taller

Fig. 1

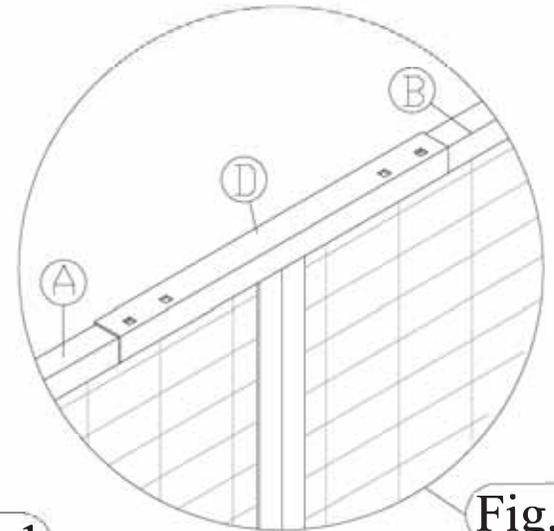

8' High Doors or Shorter

Fig. 2

## SLIDE DOOR PANEL ASSEMBLY

1. Attach door panel (A) to leaf panel(s) (B) with 3/8" x 1" bolts.
  - a. 10' wide doors have 4' 2" wide door panel, 4' wide leaf panel, and 2' wide leaf panel.
2. For 10' high doors, attach 2' high DEP panel (C)
  - a. Attach two 18" DEP Channels (D) with 3/8" x 1" carriage bolts to splice connection between door and DEP see Fig. 1.
3. For 8' high doors, attach one 18" DEP Channel (D) per joint, to top frame with 3/8" x 1" carriage bolts, see Fig. 2.
4. Attach lower angle cover bar (E) to bottom of door with 3/8" bolts and nuts.

FACE SIDE



# Slide Door Receiver

## NOTE: INSTALL SPRING PINS FIRST

1. For best results lubricate ends of the spring pins.
2. Drive the spring pin into Lock Receiver B using a standard claw hammer.
3. **Be sure the spring pin is aligned with the second hole before completing assembly.**
4. When complete spring pin will be flush on both sides



INCORRECT

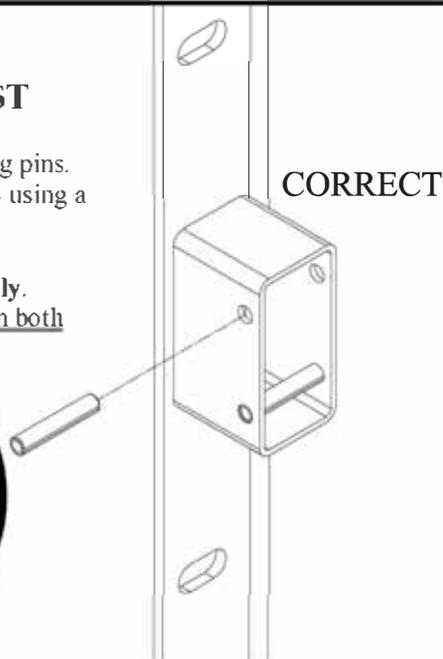

CORRECT

Note:

Component parts attach using self-drilling screws. Use variable speed screw gun with adjustable clutch or depth locating nose piece when installing self-drilling screws. **DO NOT USE IMPACT TYPE GUNS.**

## RECEIVER LOCATION :

1. Measure from floor to center of the installed slide door's lock opening—normally 41" for stock doors.
  - a. Be sure proper sweep space has been set before measuring.
2. Subtract 10" from the above measurement to get the dimension from the floor to the bottom of Lock Receiver (A)—normally 31" for stock doors.
  - a. Mark post.
3. Place leg of Lock Receiver (A) with eight slotted holes against receiver post.
  - a. See Fig.1 for receiver (A) orientation.
  - b. Align bottom of receiver with spot marked in Step 2 above.
4. Align opposing leg of Lock Receiver (A) with square holes with edge of post.
5. Attach Lock Receiver (A) to door post with four self-drilling screws.
6. Using four 5/16" x 1" carriage bolts, securely attach Lock Receiver (B) to (A).
7. Fine tune door up or down so that the door's tubular lock tongue guard overlaps lock receiver tube. **DOOR MUST BE LEVEL.**

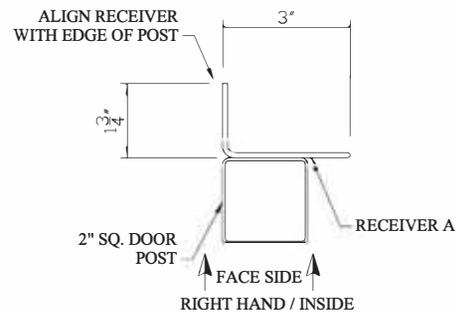
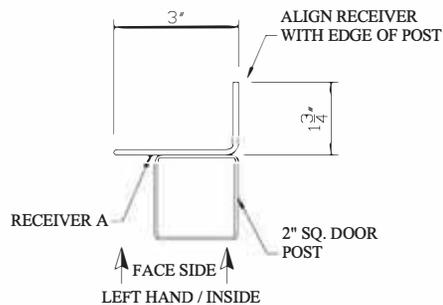
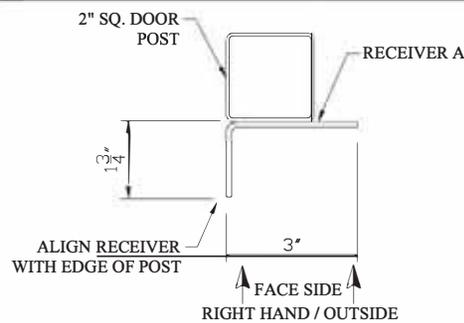
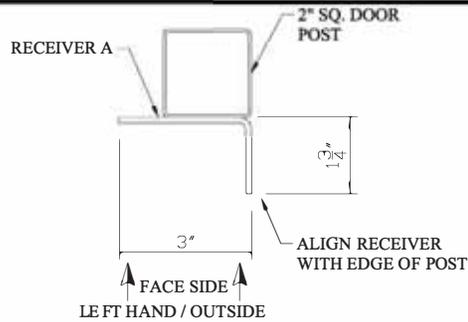
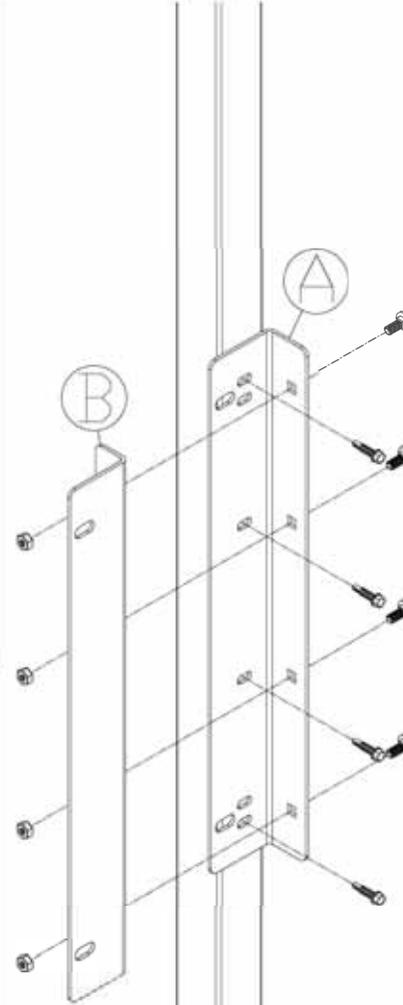
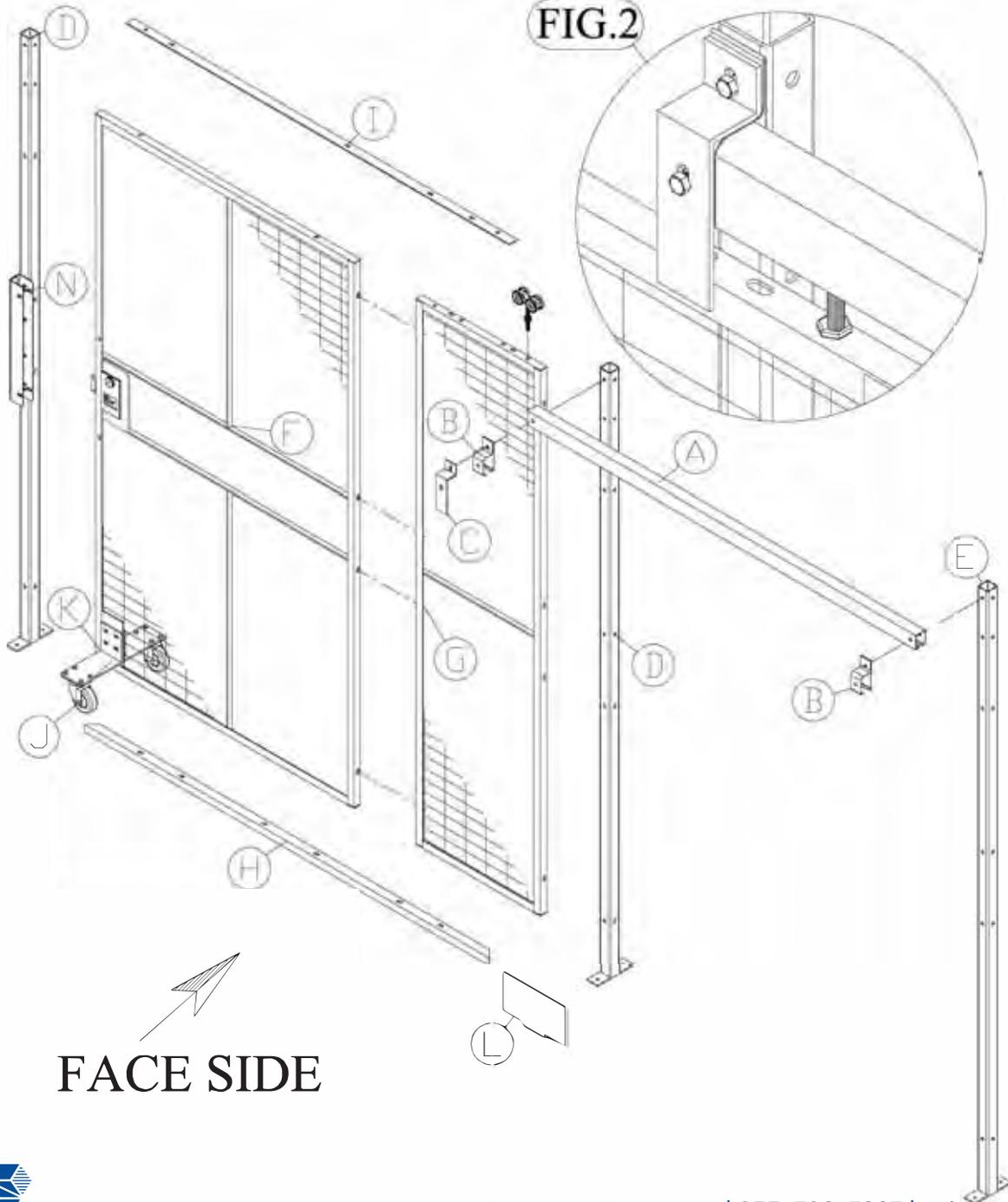

Fig.1



# Tunnel Door



## INSTALLER NOTES

- Component parts attach using self-drilling screws. Use variable speed screw gun with adjustable clutch or depth locating nose piece. Use care not to over tighten and strip threads. **DO NOT USE IMPACT TYPE GUNS.** Securely clamp part in place before attaching with self drilling screws.
- Partition wall should be set up and anchored to floor. It is **CRITICAL** that posts are plumb and in line. Door opening should be square.

## Tunnel Door

- Check that all posts are anchored and plumb.
- Place one four wheeled trolley truck in track (A).
- Using 3/8" x 1" bolt, attach Track Bracket (B) and Z-Bracket (C) to leading end of track (A) see Fig.2.
- Attach second Track Bracket (B) to far end of track (A) using 3/8" x 1" bolt.
- Mount track assembly to Posts (D) and (E) with 3/8" x 3" bolts and nuts.
  - If enclosure has ceiling use 3/8" x 1" bolts to attach track brackets.
- Assemble door panels if applicable.
  - Bolt door panel (F) to door leaf (G). (Some doors have multiple panels.)
  - Bolt Angle Cover Bar (H) to bottom of door panels (F) & (G).
  - Bolt Flat Cover Bar (I) to top of door panels (F) and (G).
- Install cylinder lock (if applicable). See page 11 for instructions.
- Mount casters (J) to caster plates (K), (two per door) with 5/16" x 1" bolts.
- Mount caster plate assemblies to door panel (F) using 3/8" x 1 1/2" bolts (use 2 washers for each bolt) see Fig. 1.
- Bolt trailing end of door to trolley inside of track (A) so that door is level.
- Lag Door Guide (L) to floor using two 3/8" anchors.
- Mount receiver (N). See page 17 for details.
- Check door operation so that it rolls smoothly, and latch engages and locks.
  - Adjust caster plates and trolley bolt if necessary.
- Tighten upper jam nut on trolley truck
  - Do not cock trolley in track when tightening jam nut. It may be necessary to hold bolt while tightening.

FIG.1

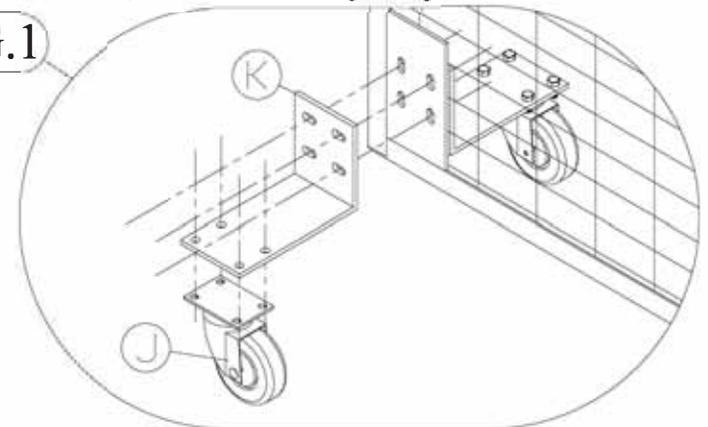

FACE SIDE



# Basic Ceiling

## INSTALL SLOTTED ANGLE

1. Cut slotted angle 1/2" shorter than panel width.
2. Install slotted angle on the top panel with one leg up to the inside of the enclosure or wall using 3/8" x 1" bolts.
3. Lift panels into place, face side up, and bolt to slotted angle with 3/8" x 1" bolts.

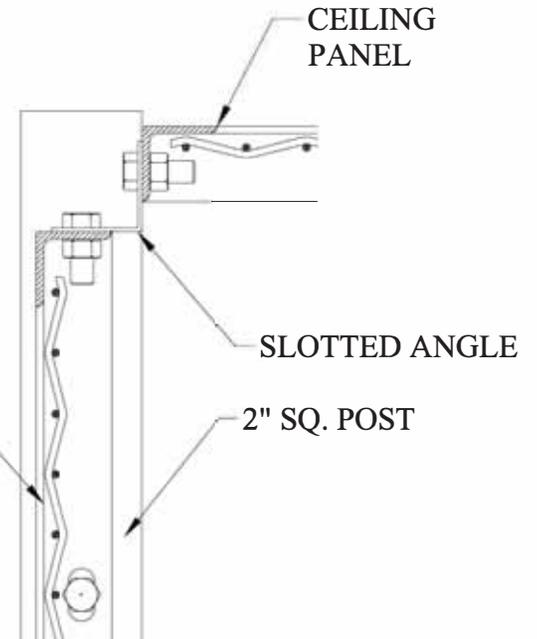
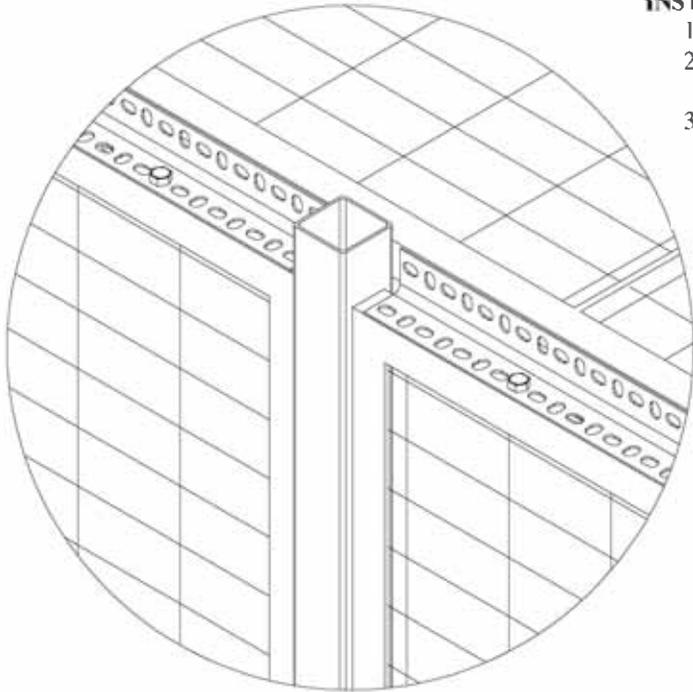

## SLOTTED ANGLE

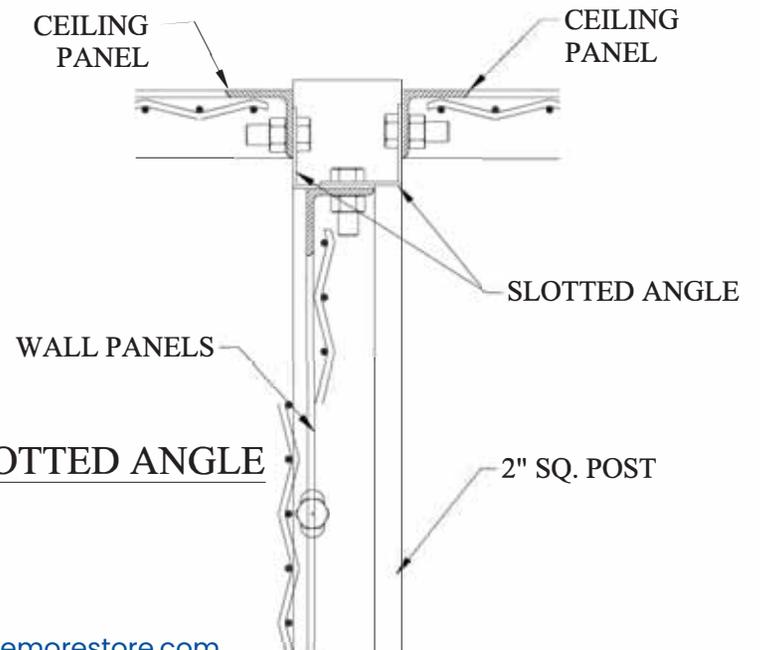
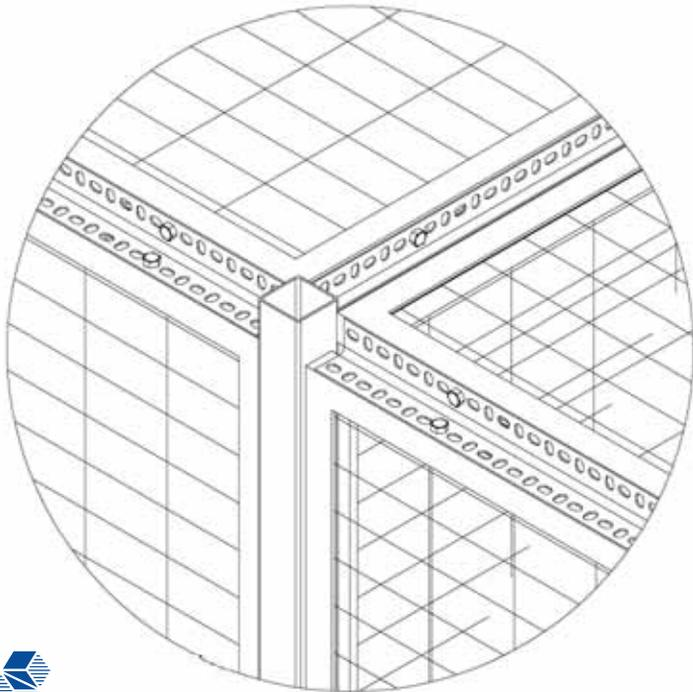

## DOUBLE-SLOTTED ANGLE



# 2" x 2" Horizontal Ceiling Tube

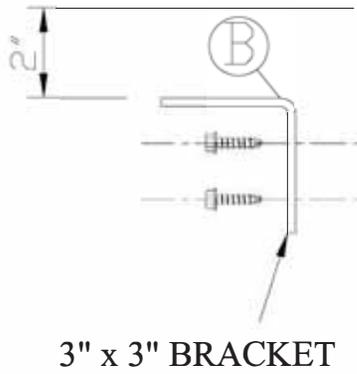
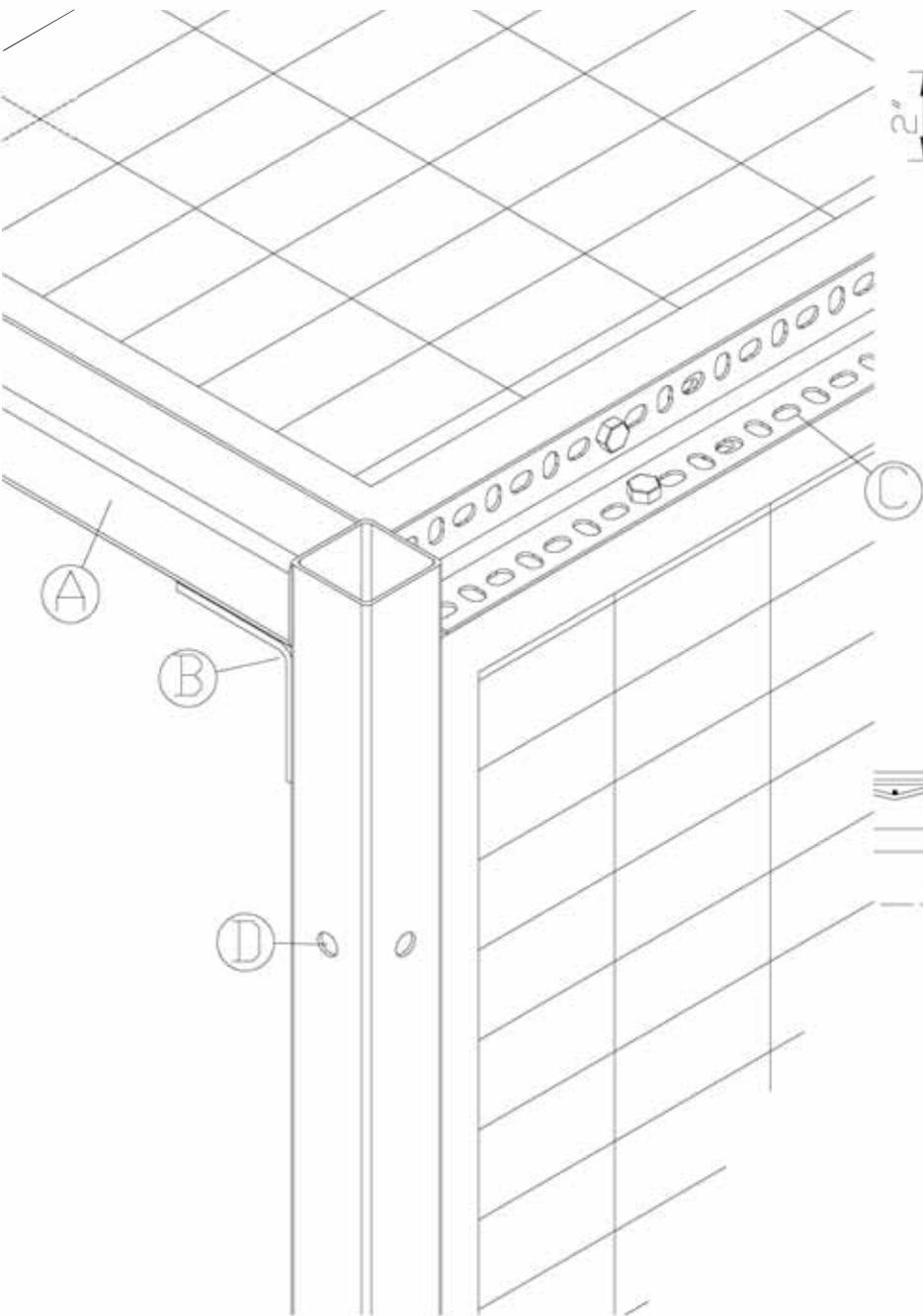

Fig.1

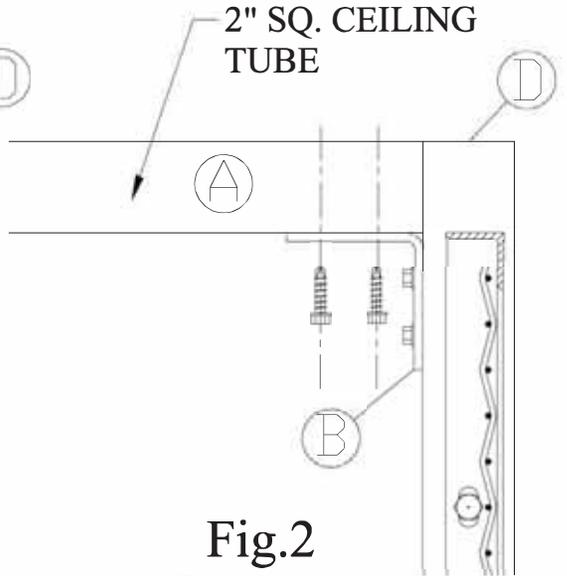

Fig.2

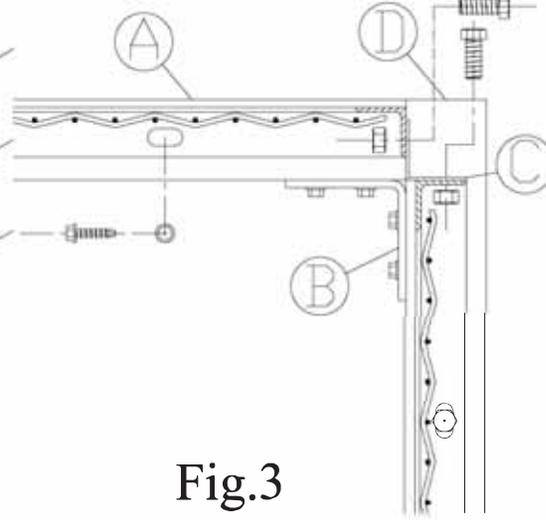

Fig.3

## 2" x 2" CEILING TUBE

1. Note overall layout of ceiling.
2. Identify location(s) of 2" x 2" horizontal ceiling tube(s) (A).
3. Using two self drilling screws, center and attach one 3/16" x 1-3/4" x 3" ceiling bracket (B) on posts (D) where horizontal ceiling tubes are to be installed.
  - a. Place so that leg of ceiling bracket is flush with top leg of wall panel per Fig.1.
  - b. Clamp part in place before using self drilling screws.
4. Align horizontal ceiling tube (A) with posts (D), attach to bracket (B) with self-drilling screws per Fig.2.
  - a. See detail page 23 if one end of ceiling tube mounts directly to building wall.
5. Install slotted angle (C) on top of wall panels per instruction page 18.
6. Lift panels into place, face side up, and attach to slotted angle with 3/8" x 1" bolts.
7. Use self drilling screws to attach panels to horizontal ceiling tubes Fig.3.
  - a. Position panels to eliminate any sag in ceiling before fastening in place.



# 2" x 4" Horizontal Ceiling Tube

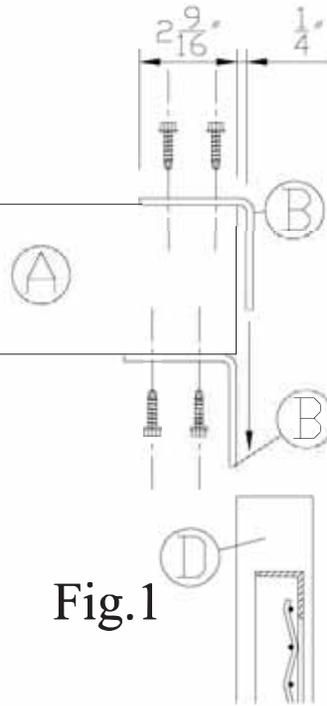
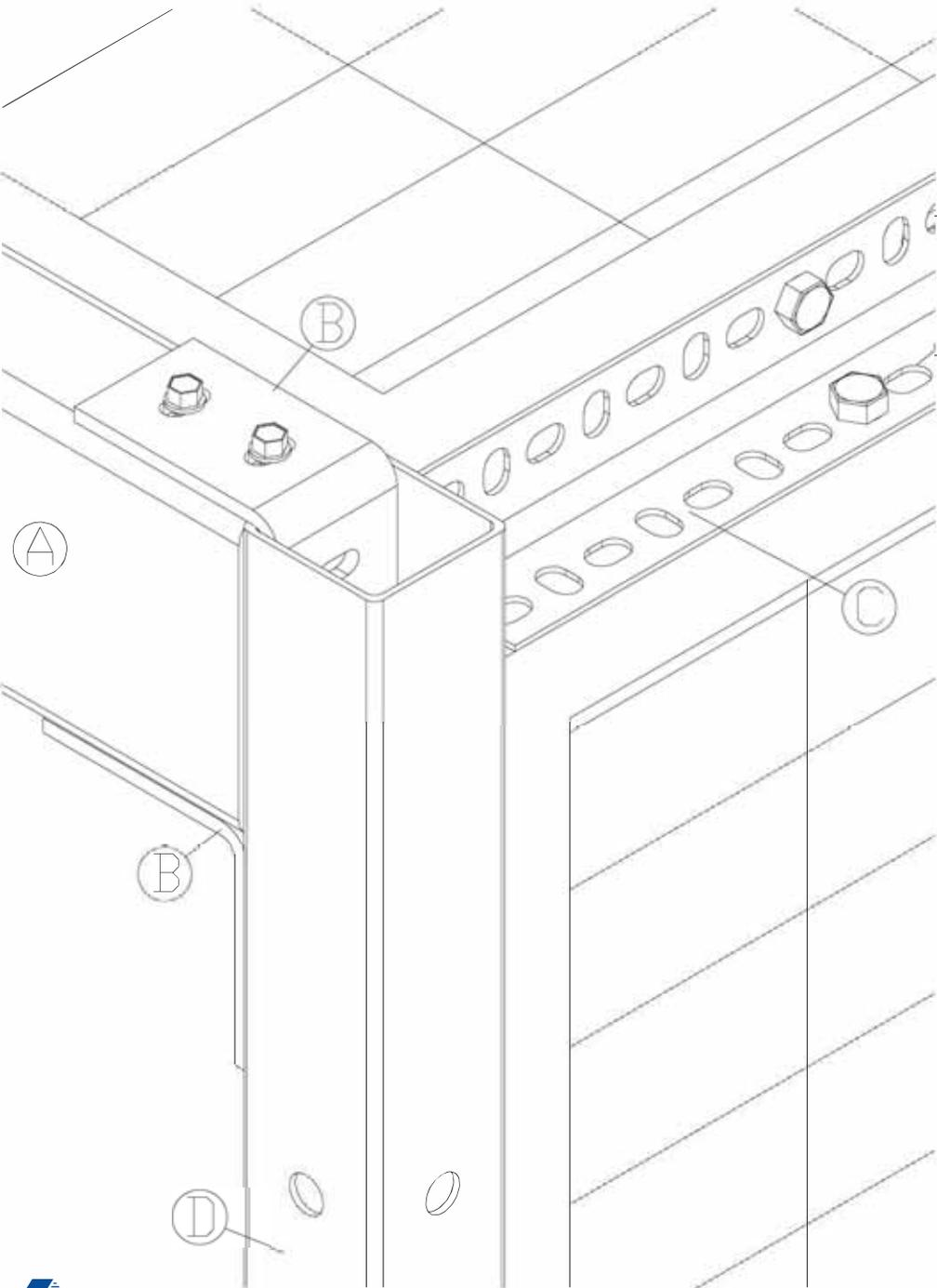

Fig.1

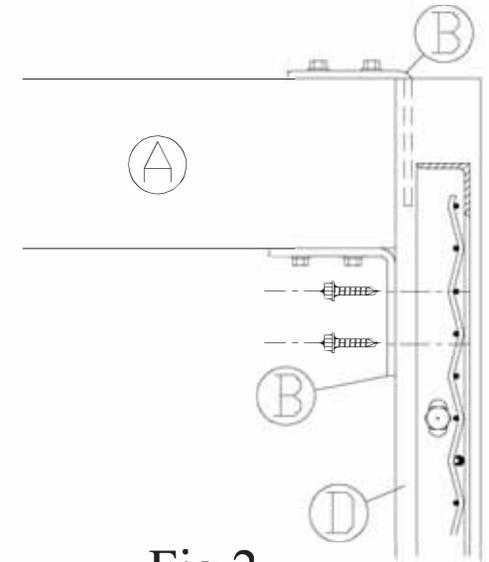

Fig.2

## 2" X 4" CEILING TUBE

1. Note location(s) of 2" x 4" horizontal ceiling tube(s) (A).
2. Center and attach one 3/16" x 1-3/4" x 3" Angle Bracket (B) to the top 2" side of 2" x 4" Ceiling Tube with two self-drill screws so that bracket leg hangs over the tube's open end.
  - a. Leave 1/4" gap between tube end and bracket leg per Fig 1.
3. Center and attach a second 3/16" x 1-3/4" x 3" Angle Bracket (B) to the bottom side of the 2" x 4" ceiling tube so that the bracket leg is flush with the end of the tube.
  - a. Both bracket legs should be pointing in the same direction. See Fig 1.
4. If opposite end of tube attaches to a post, repeat steps 2 & 3 for the opposite end of tube.
  - a. See detail page 23 if one end of ceiling tube mounts directly to building wall.
5. Lift ceiling tube (A) above the partition wall post (D) and lower into place so that the top bracket fits inside of wall post (D) Per Fig 2.
6. Align ceiling tube(A) with wall post(D) and secure lower bracket to post using self drilling screws see Fig.2
7. Install slotted angle on top of wall panels per instruction page 19.
8. Lift panels into place, face side up, and attach to slotted angle (C) with 3/8" x 1" bolts (see Fig.3 page 20).
9. Attach panels to ceiling Tube using 3/8" x 3" bolts.
  - a. Position panels to eliminate any sag in ceiling before fastening in place.



# 2" x 6" Horizontal Ceiling Tube

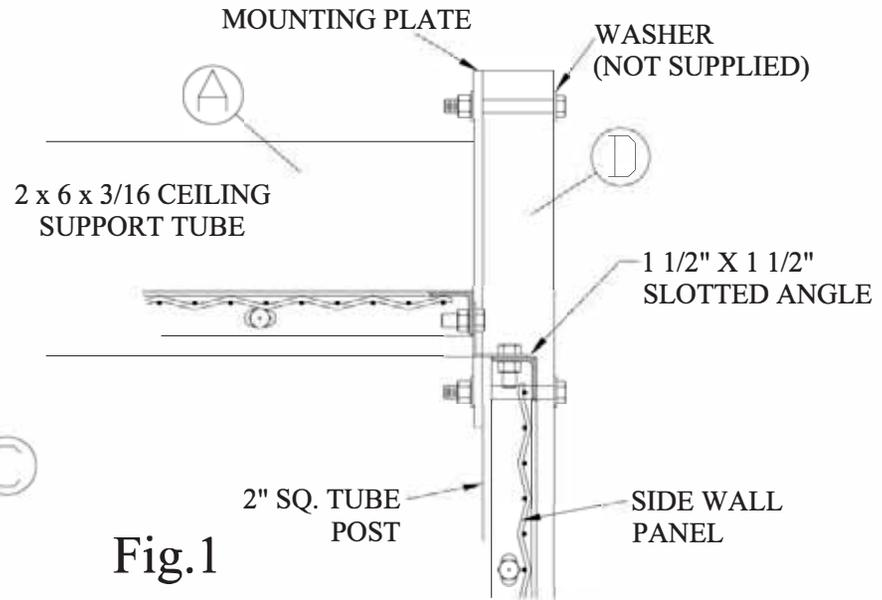
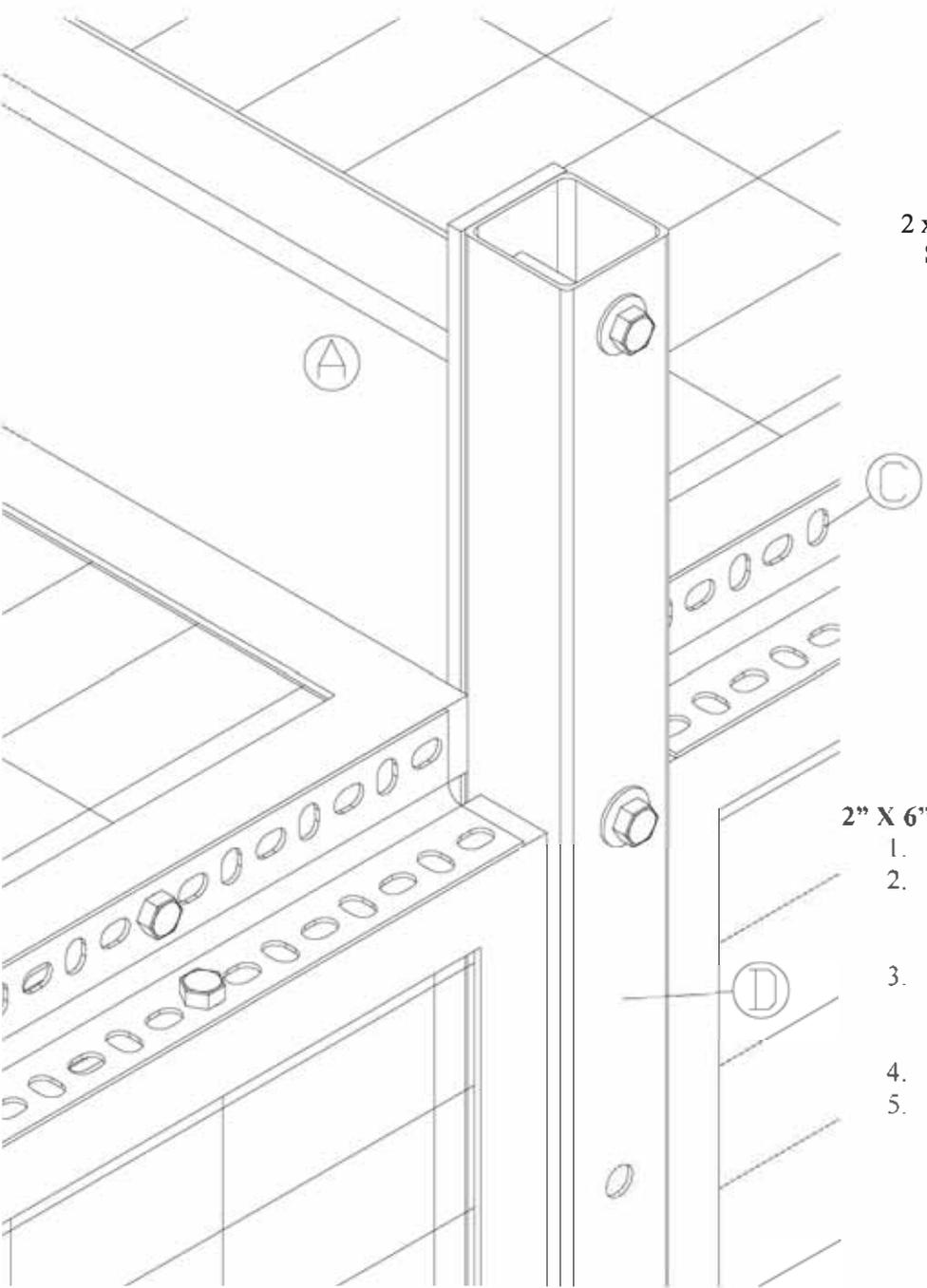

Fig.1

## 2" X 6" CEILING TUBE

1. Note location(s) of 2" x 6" horizontal ceiling tube(s) (A).
2. Lift ceiling tube (A) so that holes in mounting plates match holes at top of partition wall post (D).
  - a. See detail page 23 if one end of ceiling tube mounts directly to building wall.
3. Connect ceiling tube to wall post with two 3/8" x 3" bolts and nuts, and tighten securely.
  - a. Installer: use 3/8" flat washer (not provided) on nut and bolt side see Fig.1
4. Install slotted angle (C) on top of wall panels per instruction page 19.
5. Use 3/8" x 3" bolts to attach ceiling panels to 2" x 6" ceiling tube.



# Ceiling Tube Masonry Connections

**2" X 4" TUBE CONNECTION  
TO MASONRY WALL**

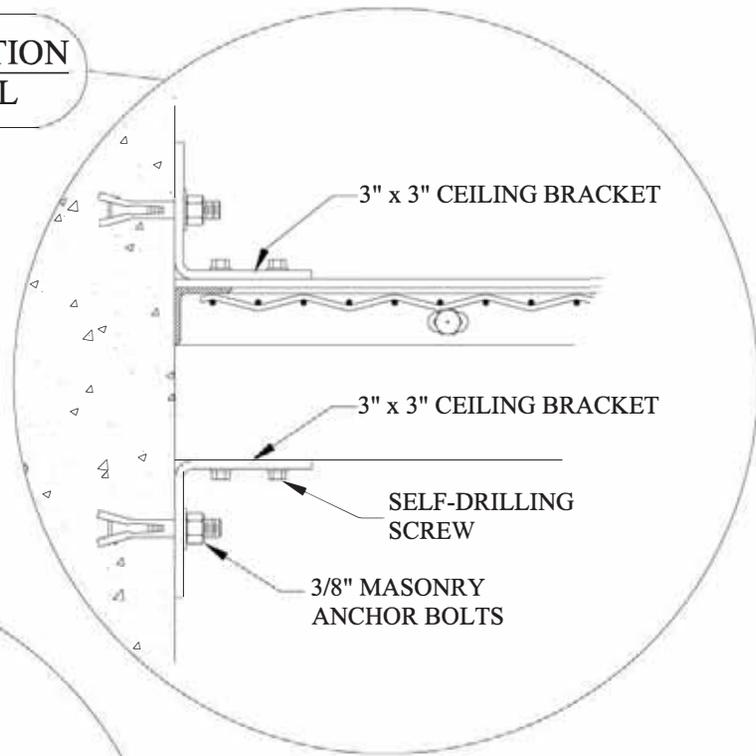
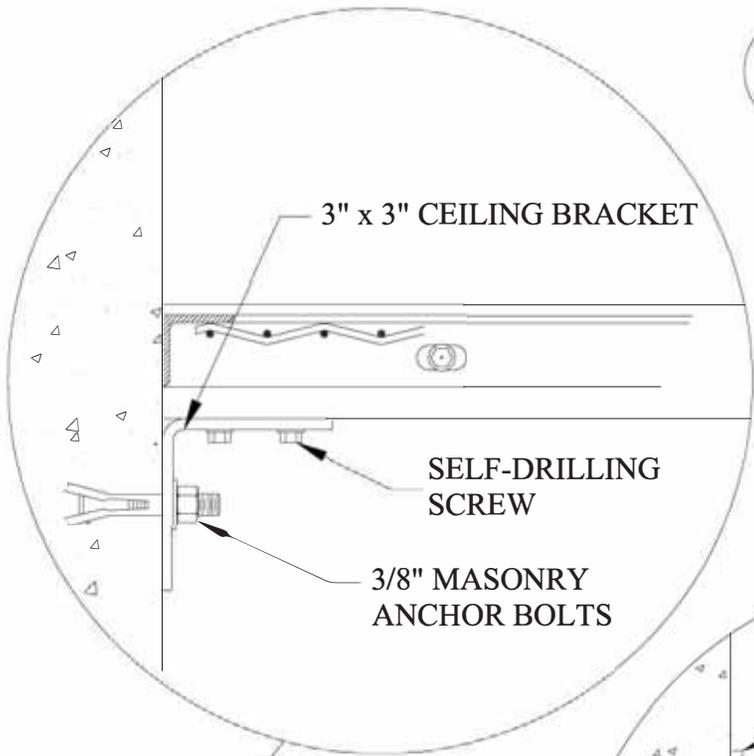

**2" X 2" TUBE CONNECTION  
TO MASONRY WALL**

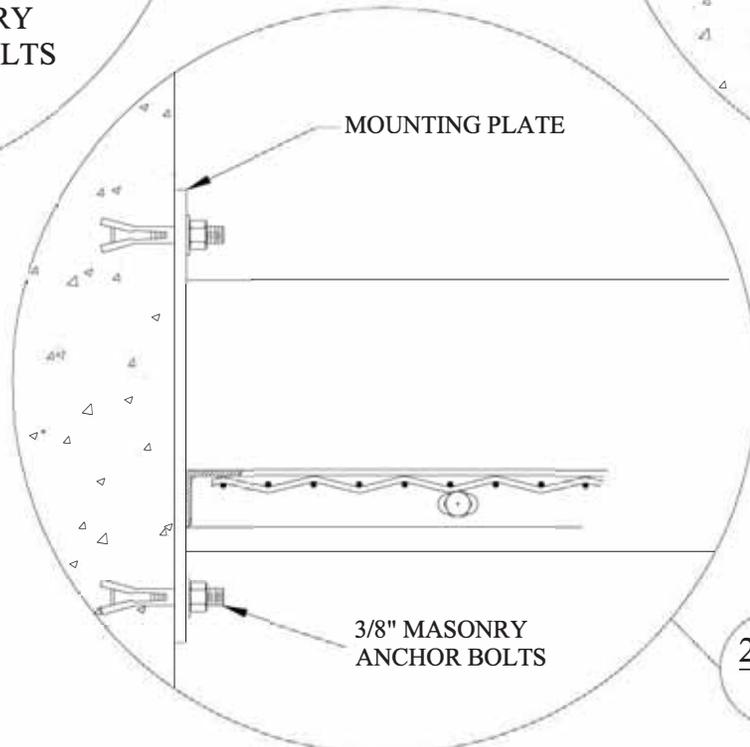

**2" X 6" TUBE CONNECTION  
TO MASONRY WALL**



# Physical Barrier 6'-2" Height

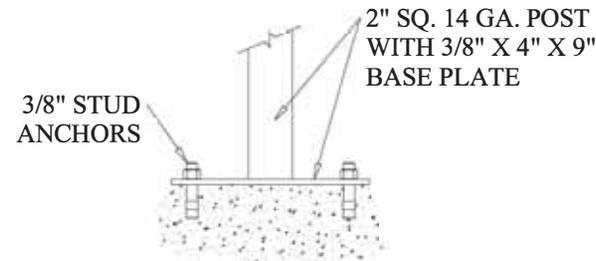
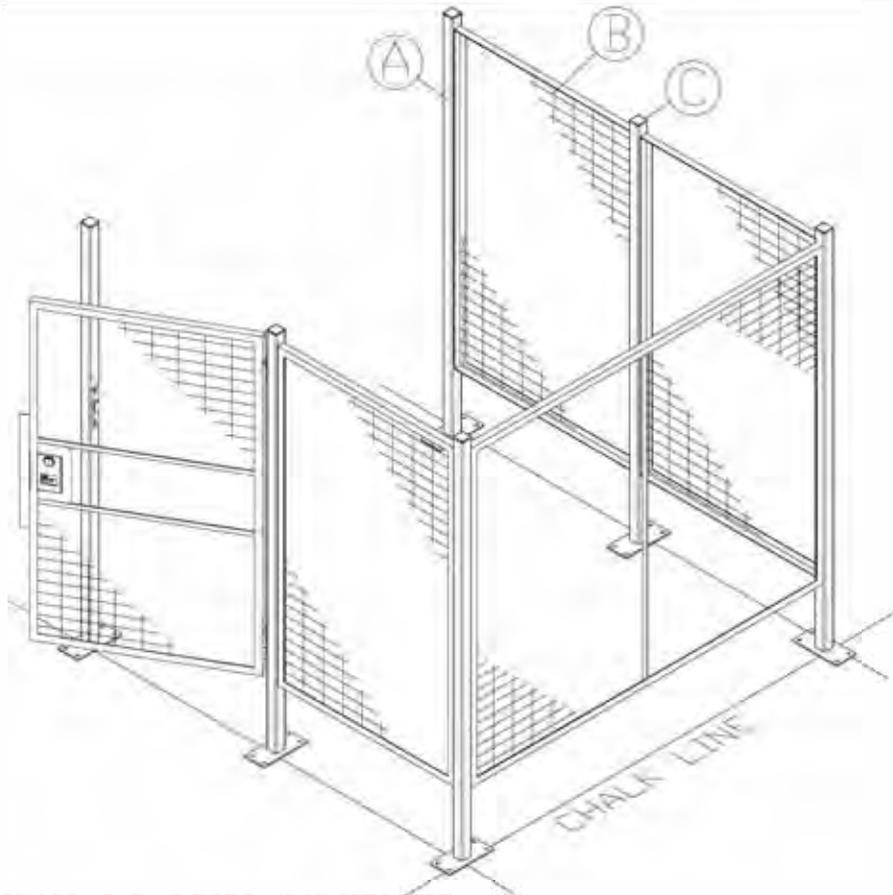

TYPICAL POST TO FLOOR CONNECTION

Fig.1

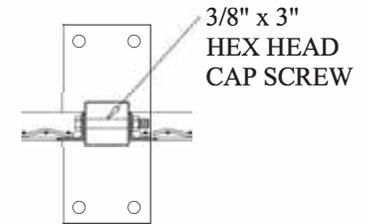

TYPICAL RUN POST CONNECTION

Fig.2

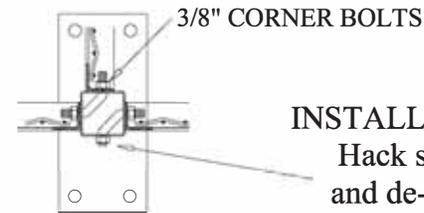

TYPICAL CORNER & TEE POST CONNECTION

Fig.3

INSTALLER NOTE  
Hack saw off  
and de-burr all  
protruding threads

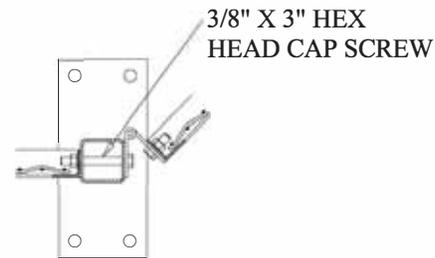

ADJUSTABLE HINGE CONNECTION

Fig.4

## PHYSICAL BARRIER 6'-2" HEIGHT PANEL & POST INSTALLATION

1. Use a chalk line to outline the partition layout on the floor.
  - a. Out to out dimensions shown on drawing are to face side of posts.
  - b. Post base plates project beyond outline of partition.
2. Lag end post (A) to floor per Fig. 1 using anchors provided.
3. Mount panel (B) to post (A)
  - a. Per Fig. 2 for straight run using two 3/8" x 3" straight bolts, or
  - b. Per Fig. 3 for 90 degree corner using two 3/8" corner bolts, or
  - c. Per Fig 4 for adjustable angle, mount hinge with 3/8" x 3" straight bolts or
  - d. If mounting directly to building wall skip this step.
  - e. **Note: Panels install horizontally; 2" mesh opening parallel with floor.**
4. Attach opposite end of panel (B) to second post (C)
  - a. Per Fig 2 for run post, or
  - b. Per Fig 3 for corner post.
5. Lag post to floor using anchors provided



# Barrier Hinge Door Outside Swing Right Hand Shown

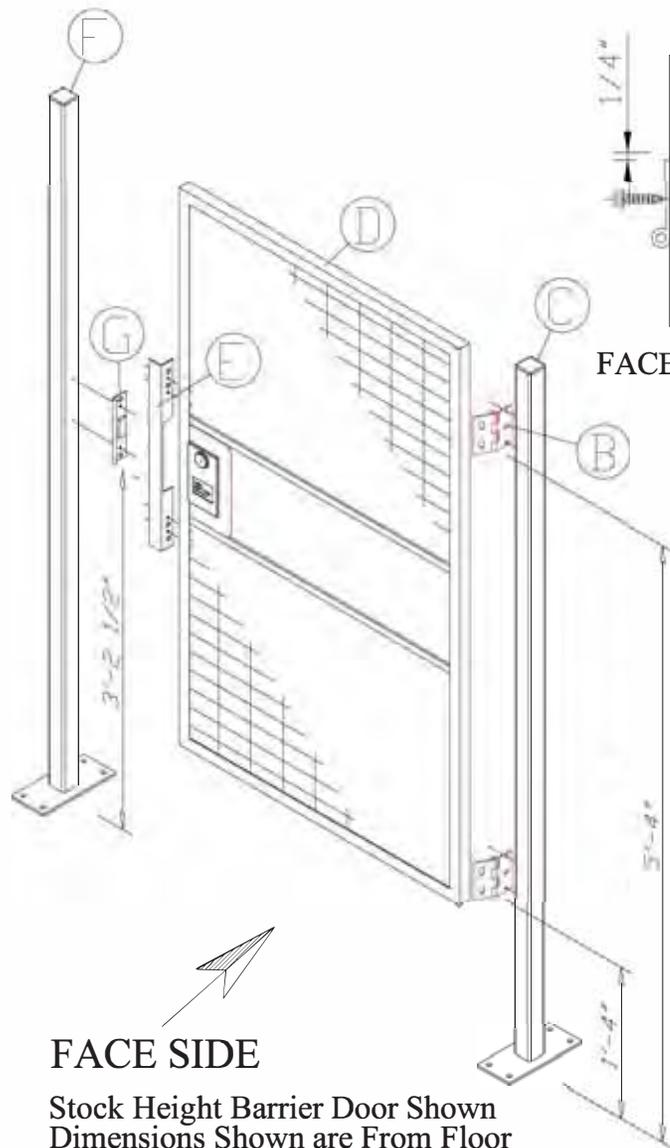

FACE SIDE

Stock Height Barrier Door Shown  
Dimensions Shown are From Floor  
to Bottom of Part

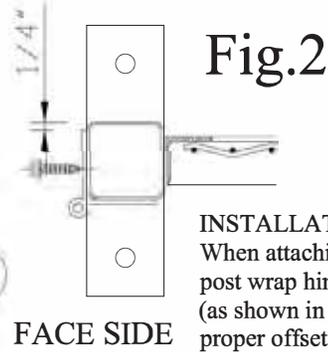

Fig. 2

**INSTALLATION TIP:**  
When attaching hinge to door  
post wrap hinge around post  
(as shown in drawing) to set  
proper offset alignment

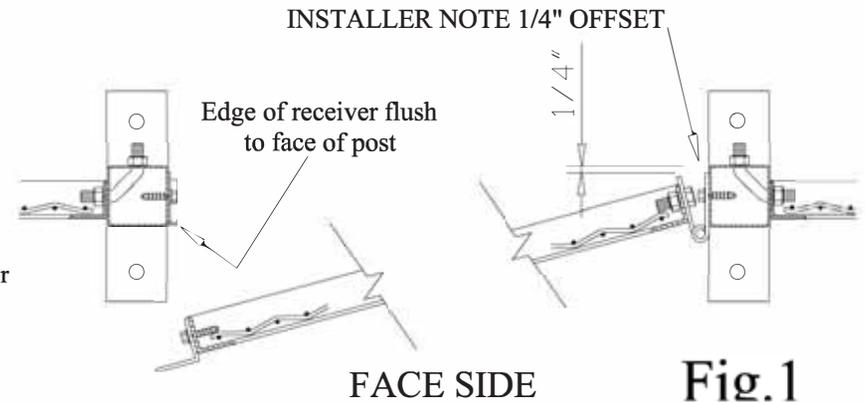

Fig. 1

## INSTALLER NOTES:

1. Component parts attach using self-drilling screws. Use variable speed screw gun with adjustable clutch or depth locating nose piece. Use care not to over tighten and strip threads. **DO NOT USE IMPACT TYPE GUNS.** Securely clamp part in place before attaching with self drilling screws.
2. The dimensions shown on this page are for standard physical barrier hinge doors 5'-0" tall with a sweep space of 1'-0". Use worksheet on page 29 to calculate component locations for non-standard door opening heights or sweep spaces.
3. Partition wall should be set up and anchored to floor, with posts plumb before attempting to install doors.

## Physical Barrier Hinge Door Outside Swing

1. Check opening width at floor, and anchor posts to floor.
  - a. Check that posts are plumb and opening is square.
2. Attach hinges (B) to door post (C) using two self drilling screws per hinge.
  - a. Note hinge placement offset detailed in Fig 1 and install tip Fig 2.
  - b. If necessary, remove two 3/8" x 3" panel mounting bolts and replace with corner bolts. Cut off and file smooth any protruding bolt threads.
3. Attach door panel (D) to hinges with two 3/8" x 1" bolts and nuts per hinge.
  - a. Set desired sweep space (12" for stock doors).
4. Attach pick plate (E) to door panel (D) using four self drilling screws.
  - a. Pick plate should be centered over lock tongue hole.
  - b. Bottom of pick plate installs 20" from bottom of stock doors.
5. Attach cylinder lock receiver (G) to door post (F) with two self-drilling screws.
  - a. Rolled side of receiver installs to face side of partition.
  - b. Bottom of receiver installs 38-1/2" from floor for stock doors.
6. Install cylinder lock (if applicable). See page 6.
7. Check operation of door, adjust as needed.



# Barrier Hinge Door Inside Swing Right Hand Shown

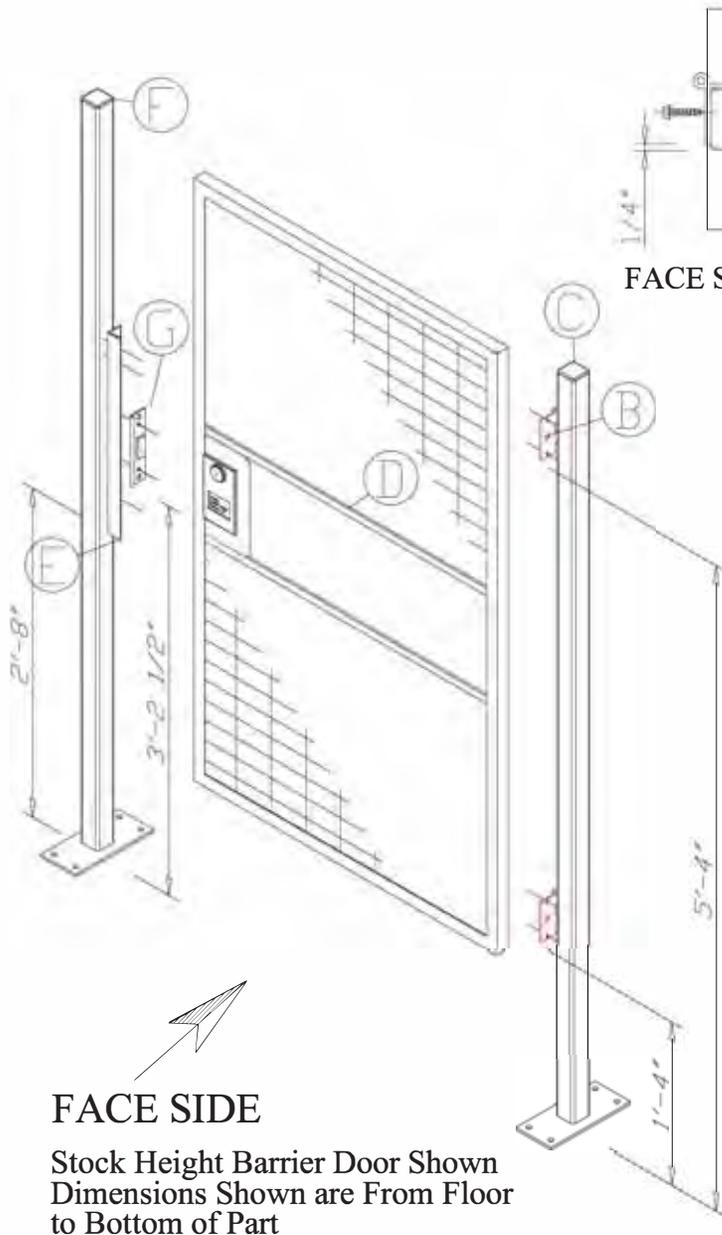

FACE SIDE

Stock Height Barrier Door Shown  
Dimensions Shown are From Floor  
to Bottom of Part

Fig.2

FACE SIDE

INSTALLATION TIP:  
When attaching hinge to door  
post wrap hinge around post  
(as shown in drawing) to set  
proper offset alignment

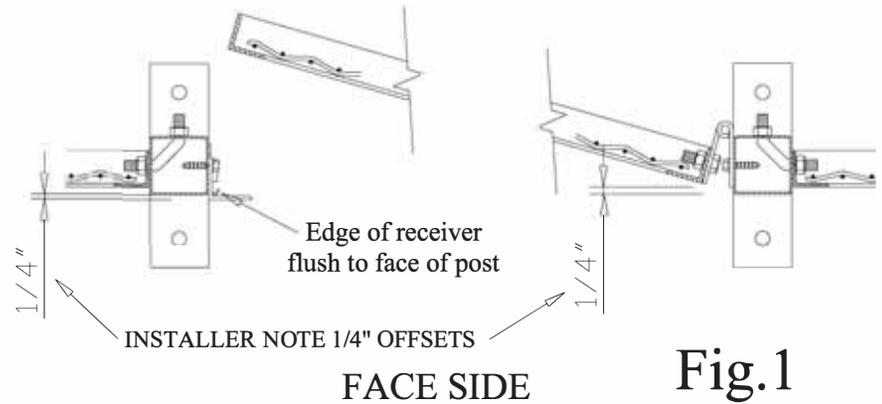

Fig.1

## INSTALLER NOTES:

1. Component parts attach using self-drilling screws. Use variable speed screw gun with adjustable clutch or depth locating nose piece. Use care not to over tighten and strip threads. **DO NOT USE IMPACT TYPE GUNS.** Securely clamp part in place before attaching with self drilling screws.
2. The dimensions shown on this page are for standard physical barrier hinge doors 5'-0" tall with a sweep space of 1'-0". Use worksheet on page 29 to calculate component locations for non-standard door opening heights or sweep spaces.
3. Partition wall should be set up and anchored to floor, with posts plumb before attempting to install doors.

## Physical Barrier Hinge Door Inside Swing

1. Check opening width at floor, and anchor posts to floor.
  - a. Check that posts are plumb and opening is square.
2. Attach hinges (B) to door post (C) using two self drilling screws per hinge.
  - a. Note hinge placement offset detailed in Fig. 1 and install tip in Fig. 2.
  - b. If necessary, remove two 3/8" x 3" panel mounting bolts, and replace with corner bolts. Cut off and file smooth any protruding bolt threads.
3. Attach door panel (D) to hinges with two 3/8" x 1" bolts and nuts per hinge.
  - a. Set desired sweep space (12" for stock doors).
4. Attach pick plate (E) to door post (F) using four self drilling screws.
  - a. Note pick plate position offset detailed in Fig. 1.
  - b. Bottom of pick plate installs 32" from floor for stock doors.
5. Attach cylinder lock receiver (G) to door post (F) with two self-drilling screws.
  - a. Rolled side of receiver installs to face side of partition.
  - b. Bottom of receiver installs 38-1/2" from floor for stock doors
6. Install cylinder lock (if applicable). See page 6.
7. Check operation of door, adjust as needed.



# Rack Back

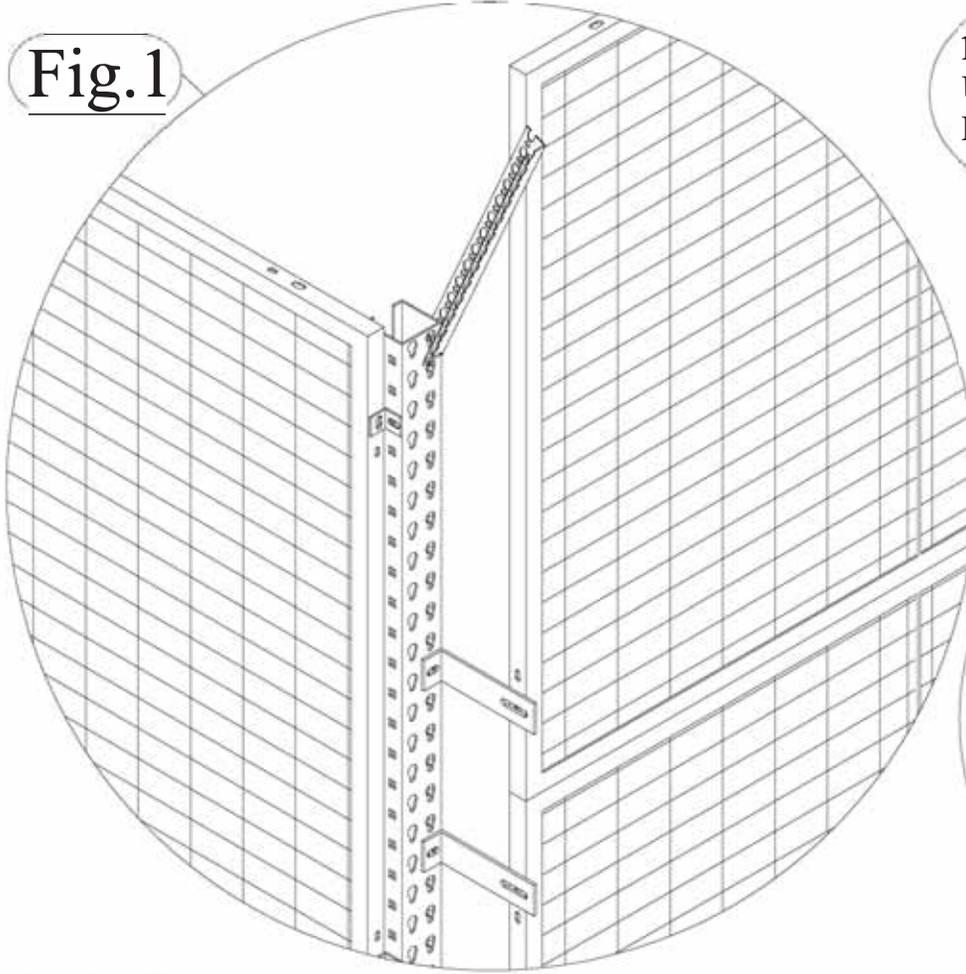

**Fig. 1**

1 5/8" to 3 1/4" Offset  
 Uses 4 1/2" x 1 1/2" Bracket  
 Part# OPANCL412112

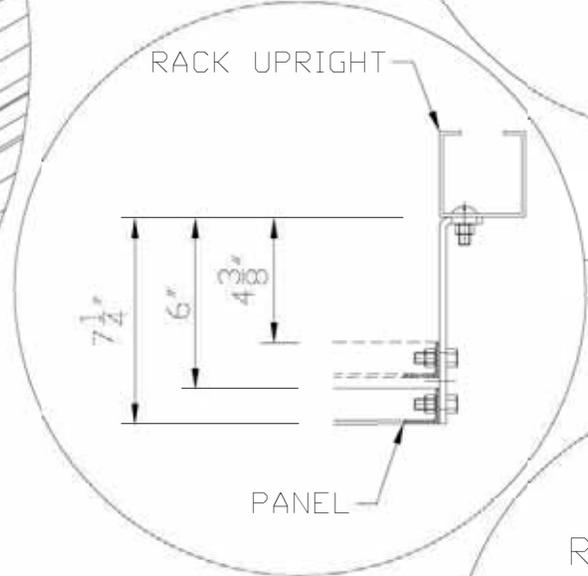
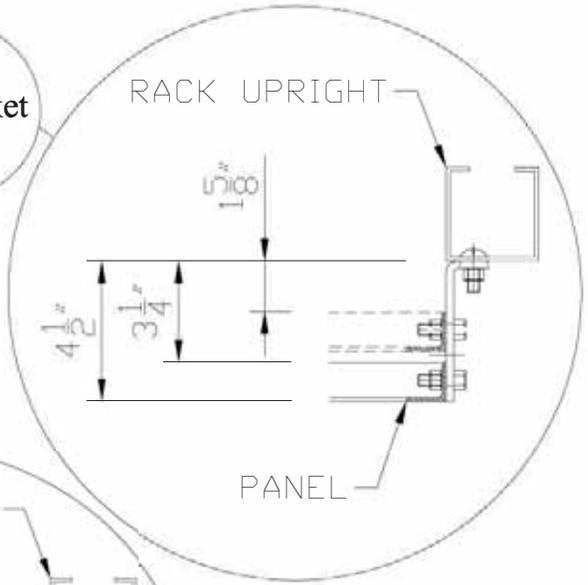

4 3/8" to 6" Offset  
 Uses 7 1/4" x 1 1/2" Bracket  
 Part# OPANCL714112

Flush Mount  
 Uses 1 1/4" x 1/14" Bracket  
 Part# OPANCL114182H

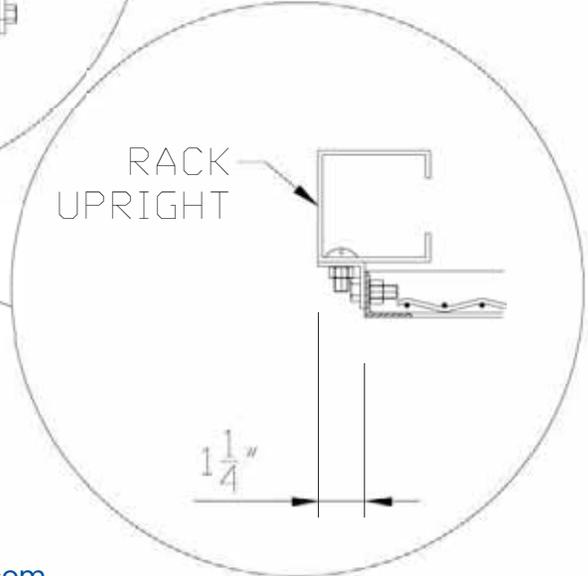

**INSTALLER NOTES**

1. Provided mounting hardware may not be appropriate for all types of rack. Installer may need to acquire additional or other type fasteners.
2. It is installer's responsibility to securely install brackets and panels to rack structure.

**Rack Back® Panels**

1. Note slotted hole location on end of panels. Attach mounting bracket to rack uprights corresponding to holes on end of panels.
2. Lift panels into place between mounting brackets, and secure with 3/8" x 1" bolt.
3. Align panels with those above or below to form wall and connect horizontal members of panels with 3/8" x 1" bolts.
4. Panels rising above rack structure may be secured with slotted angle. See Fig. 1.

# Rack Back® Hinge Door

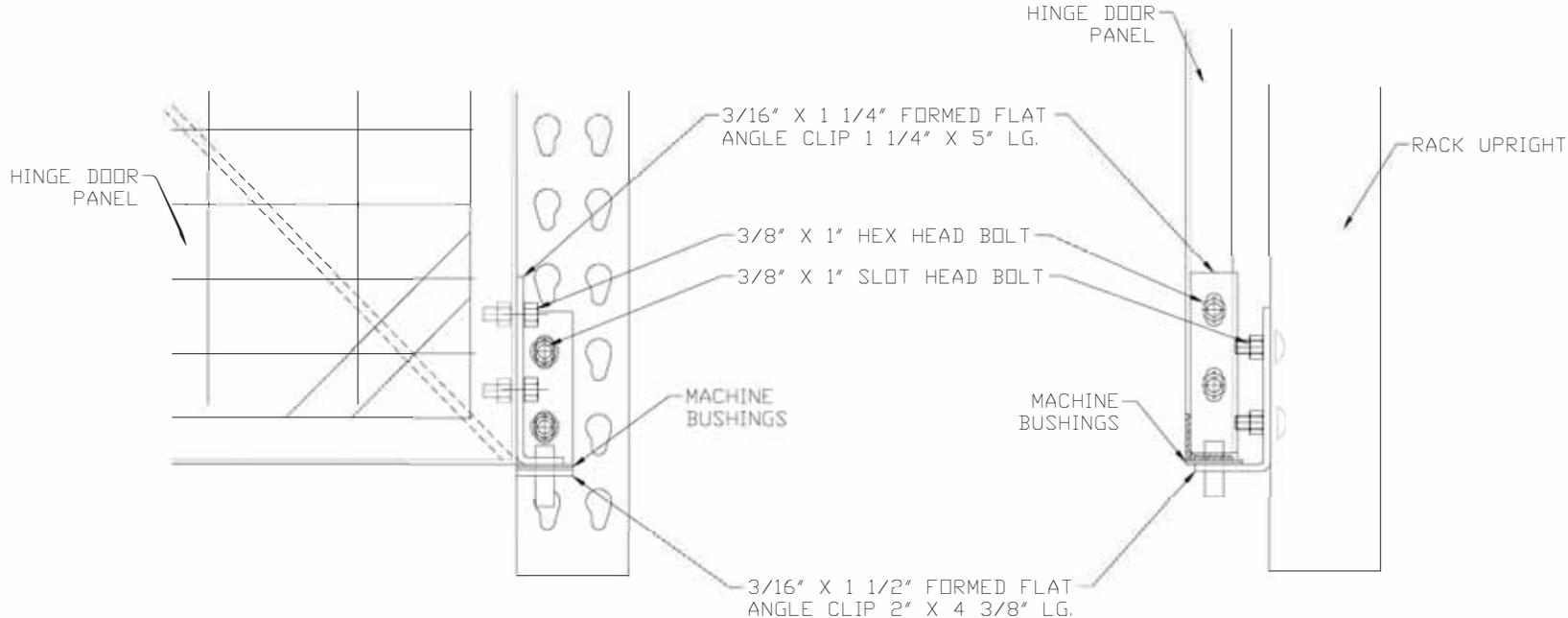

**DETAIL  
FRONT VIEW**

**DETAIL  
SIDE VIEW**

## INSTALLER NOTES

1. Provided mounting hardware may not be appropriate for all types of rack. Installer may need to acquire additional or other type fasteners.

## Rack Back® Hinge Gates

1. Locate gate hinge brackets (brackets with pins attached) and machine bushings.
2. Use 3/8" x 1" bolts to install gate hinge bracket on outside corners of gate panel (pins should be pointing in opposite directions after installed).
3. Install only lower receiver bracket (bracket with no pin) on rack upright at desired sweep space.
4. Place bushing over hinge pin, and lift gate into place so that lower hinge pin fits into lower receiver bracket.
5. Place upper receiver bracket over hinge pin and fasten receiver to rack.
  - a. Check that top of gate is level, and overall operation of gate.
6. If double hinge gate, repeat procedure for opposite door panel.
  - a. Use same sweep space dimension as first panel.
  - b. Check that gap between doors is sufficient for operation of doors and lock device, if not adjust mount brackets appropriately.
7. If single hinge gate, align padlock lug with door lug and attach to rack.

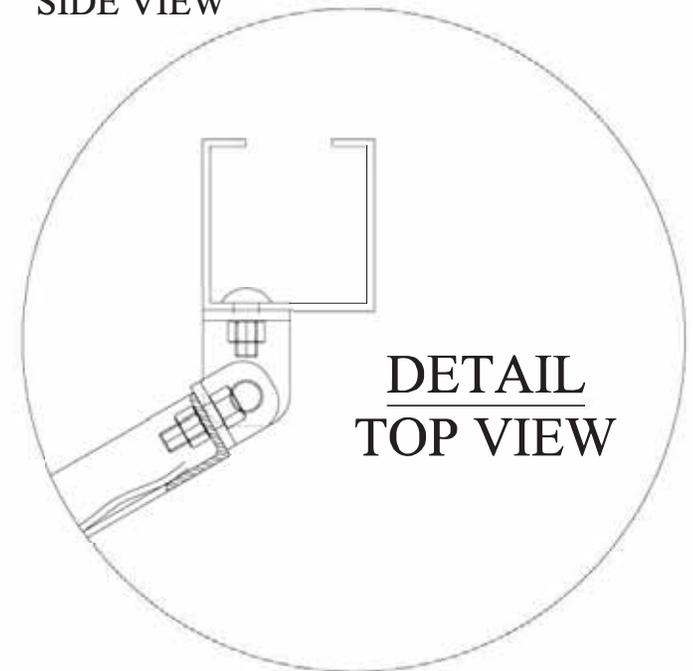

**DETAIL  
TOP VIEW**

# NON-STOCK COMPONENT LOCATION WORK SHEET

All locations are from floor to bottom of component

Fill in blanks with appropriate Dimensions before starting calculations

Sweep Space \_\_\_\_\_  
Door Leaf Height \_\_\_\_\_  
Center Line of Door \_\_\_\_\_ (Divide Door Leaf Height in Half)  
Center Line of Tongue Hole in Door Leaf \_\_\_\_\_  
Bottom Door Leaf Height \_\_\_\_\_ (Dutch Door Only)  
Top Door Leaf Height \_\_\_\_\_ (Dutch Door Only)

## Hinge Door Components

Bottom Hinge Location : Sweep Space + 4" = \_\_\_\_\_

Center Hinge Location : (Sweep Space + Center line of Door) then subtract 2" = \_\_\_\_\_

Top Hinge Location : (Door Height + Sweep Space) then subtract 8" = \_\_\_\_\_

Receiver Location : (Center Line of Tongue Hole in Door Leaf + Sweep Space) then Subtract 3 1/2" = \_\_\_\_\_

Angle Pick Plate : (Center Line of Tongue Hole in Door Leaf + Sweep Space) then Subtract 10" = \_\_\_\_\_ (Inside Swing Only)

## Dutch Door Components

Bottom Hinge Bottom Leaf : Sweep Space + 4" = \_\_\_\_\_

Top Hinge Bottom Leaf : (Sweep Space + Bottom Door Leaf Height) then subtract 8" = \_\_\_\_\_

Bottom Hinge Top Leaf : Bottom Door Leaf Height + Sweep Space + 5/8" + 4" = \_\_\_\_\_

Top Hinge Top Leaf : (Bottom Door Leaf Height + Sweep Space + 5/8" + Top Door Leaf Height) then subtract 8" = \_\_\_\_\_

Receiver Location : (Center Line of Tongue Hole in Door Leaf + Sweep Space) Subtract 3 1/2" = \_\_\_\_\_

