

# Transparent Locker Assembly Guide

## SMS-05-V39-USVP

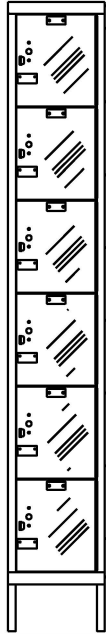

1 WIDE  
6 TIER  
FRONT VIEW

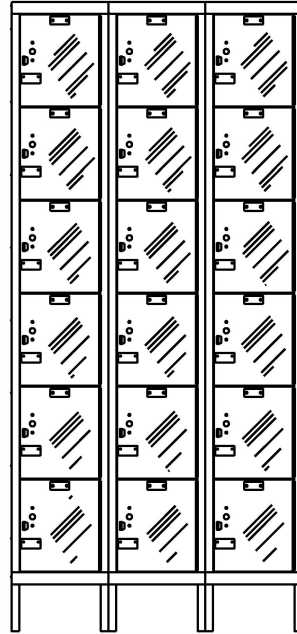

3 WIDE  
6 TIER  
FRONT VIEW

### **General Instructions**

1. Check material received against the packing list. First check the number of packages received and then check the contents of each package.
2. Check material received for damage. If damage has occurred, secure a "damage notation" from the carrier.
3. Identify each part as it is unpacked and put like parts together as close as possible to the working area in which they are to be assembled.
4. Be careful to use the correct hardware as specified in the assembly instructions.
5. Items with suffix (xx) are available options.

### **CAUTION**

IN THE INTEREST OF SAFETY, ALL LOCKERS MUST BE SECURELY ANCHORED TO THE FLOOR AND/OR WALL.  
FOR SAFETY, HANDLE ALL COMPONENTS CAREFULLY AND WEAR WORK-GLOVES WHEN ASSEMBLING LOCKERS.  
INSTALL ALL UNITS PLUMB AND TIGHTEN ALL HARDWARE SECURELY.  
RETAIN INSTRUCTIONS FOR FUTURE REFERENCE.



# 6-TIER PACKAGE CONTENTS

REF NO.	DESCRIPTION	PART NO.	1 WIDE QUANTITY 6 TIER	3 WIDE QUANTITY 6 TIER
①	REAR PANEL	KRww72	1	3
②	RIGHT/LEFT SIDE PANEL	KPdd72	2	4
③	TOP/BOTTOM SHELF	KSwwdd	2	6
④	INTERMEDIATE SHELF	KHwwdd	5	15
⑤	DOOR FRAME ASSEMBLY	LKDFww78-6SV	1	3
x ⑥	DOOR	LKDww72-6SVP	6	18
⑦	BOX DOOR LATCH PULL	KBLP100	6	18
⑧	NUMBER PLATE	NPH	6	18
⑨	NUMBER PLATE RIVET	RV101	12	36
x ⑩	STRIKE PLATE	xxSP100	xx6	xx18
⑪	REAR LEG	KLG	2	2
⑫	3/8" SLOTLESS BOLT	MBT200	94	282
⑬	HEX NUT	N201	82	246
⑭	HI-DOME CAP NUT	N110	12	36
x ⑮	PIANO HINGE	xPH11	6	18
x ⑯	HINGE (HINGE)	RV102	12	36

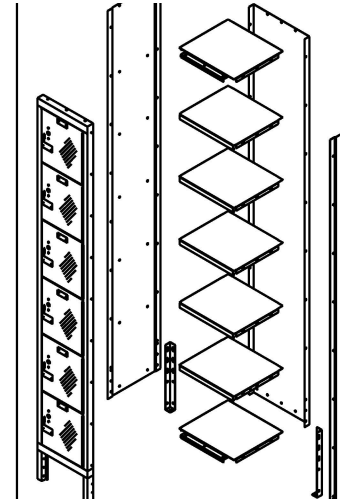

1-Wide  
6-Tier  
KD Locker

PART NUMBER SUFFIX SHOW  
WIDTH, DEPTH, HEIGHT AND TIER  
CUSTOMER TO SPECIFY.

## NOTE:

FOR OPTIONAL INDIVIDUAL SLOPE TOPS,  
SEE SUPPLEMENTAL INSTRUCTION SHEET NO. ASY-H-KIST-A

FOR OPTIONAL 6" HIGH CLOSED METAL BASE,  
SEE SUPPLEMENTAL INSTRUCTION SHEET NO. ASY-H-KIST-B

x SHIPS PRE-HUNG IN FRAME ASSEMBLY

xx STRIKE PLATES ARE OPTIONAL - INCLUDES TWO RIVETS ⑨

## PART NO. LEGEND:

dd = DEPTH  
ww = WIDTH

**TOOLS REQUIRED: 3/8" NUT  
DRIVER (3/8" SOCKET MAY BE  
SUBSTITUTED)**



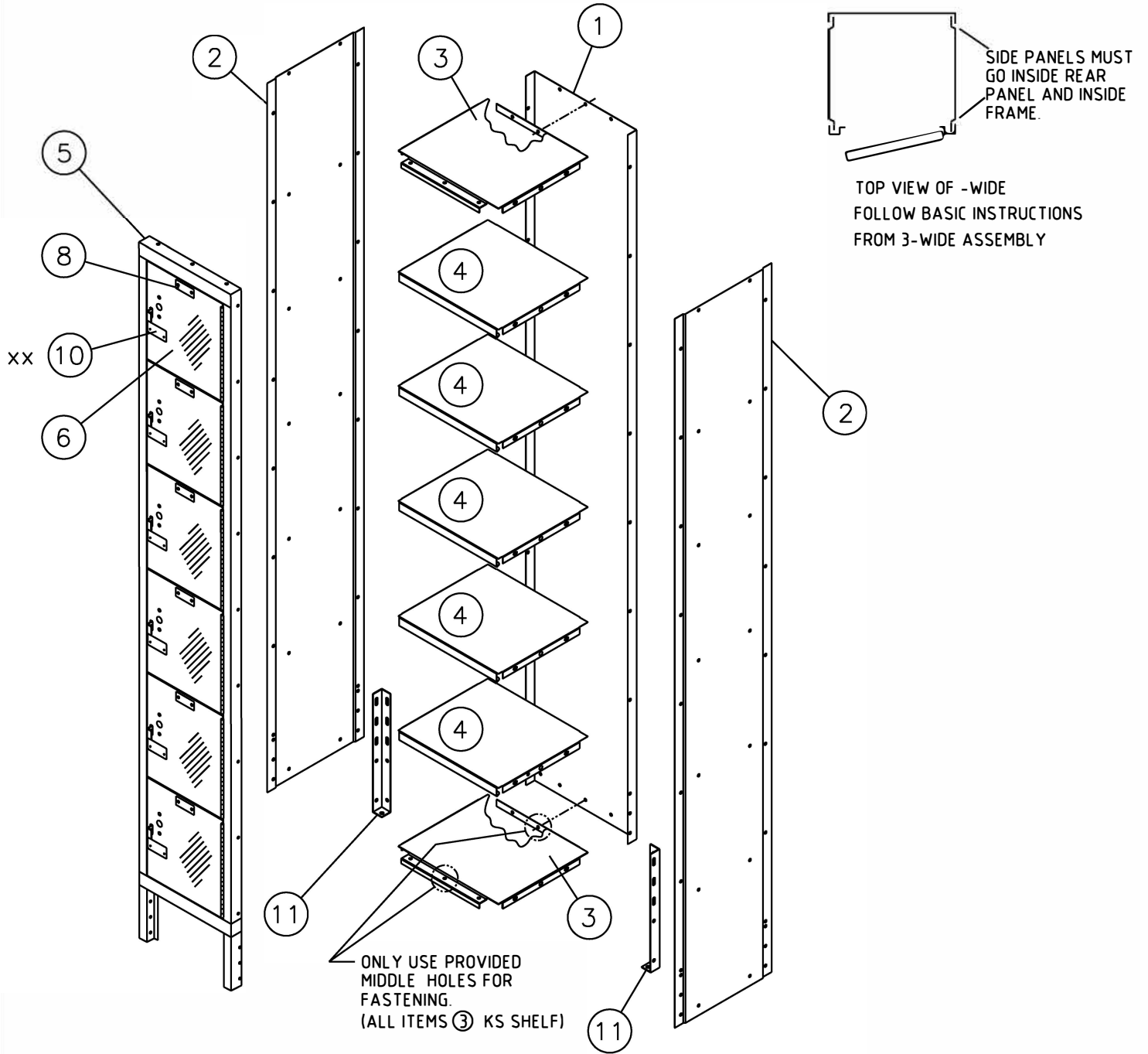

HALLOWELL MAKES EVERY EFFORT TO ENSURE THAT ALL UNITS SHIP COMPLETE. HOWEVER, SHOULD YOUR UNIT CONTAIN MISSING OR DAMAGED PARTS, REPLACEMENTS MAY BE OBTAINED FROM HALLOWELL. TO OBTAIN PARTS, FOLLOW THESE INSTRUCTIONS.

PLEASE PROVIDE THE FOLLOW INFORMATION:



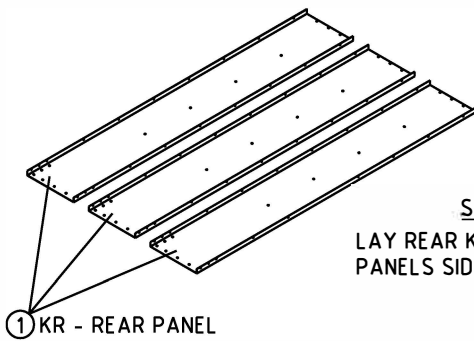

**STEP 1**  
LAY REAR KR ①  
PANELS SIDE BY SIDE.

① KR - REAR PANEL

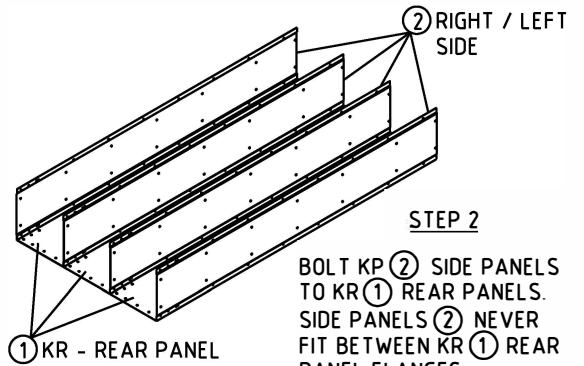

**STEP 2**  
BOLT KP ② SIDE PANELS  
TO KR ① REAR PANELS.  
SIDE PANELS ② NEVER  
FIT BETWEEN KR ① REAR  
PANEL FLANGES.

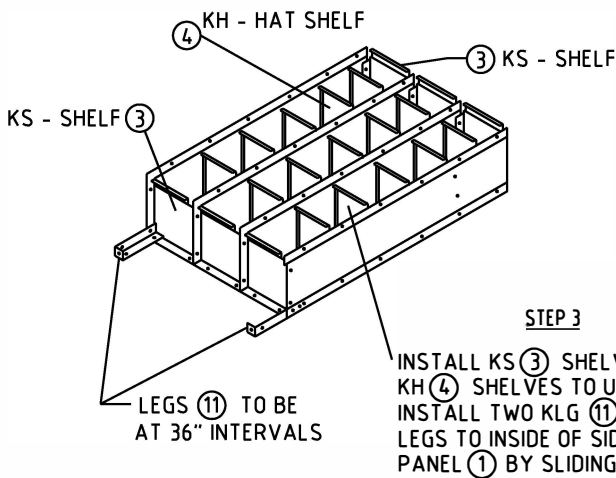

**STEP 3**

INSTALL KS ③ SHELVES AND  
KH ④ SHELVES TO UNIT.  
INSTALL TWO KLG ⑪ REAR  
LEGS TO INSIDE OF SIDE ②  
AND REAR  
PANEL ① BY SLIDING INTO PLACE FROM BOTTOM.

KS - SHELF ③

KH - HAT SHELF ④

③ KS - SHELF

LEGS ⑪ TO BE  
AT 36" INTERVALS

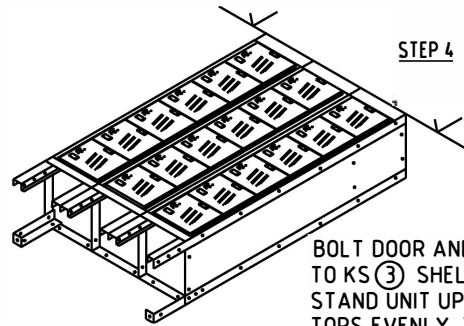

**STEP 4**

BOLT DOOR AND FRAME ⑤ ASSEMBLIES  
TO KS ③ SHELVES AND KP ② SIDE PANELS.  
STAND UNIT UP AND ALIGN LOCKER  
TOPS EVENLY. TIGHTEN ALL BOLTS  
AND NUTS.  
NOTE: WHEN BOLTING ONE UNIT TO  
ANOTHER, OMIT ONE SET OF BOLTS  
IN END FRAME AND SIDE TO MINIMIZE  
GROWTH FROM BOLT HEADS.

**ASSEMBLY OF SINGLE ROW LOCKERS**  
NEVER PUT SIDE PANELS BETWEEN FRAMES.

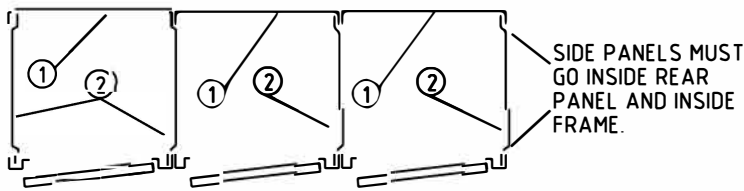

3 WIDE UNIT PLAN VIEW

SIDE PANELS MUST  
GO INSIDE REAR  
PANEL AND INSIDE  
FRAME.

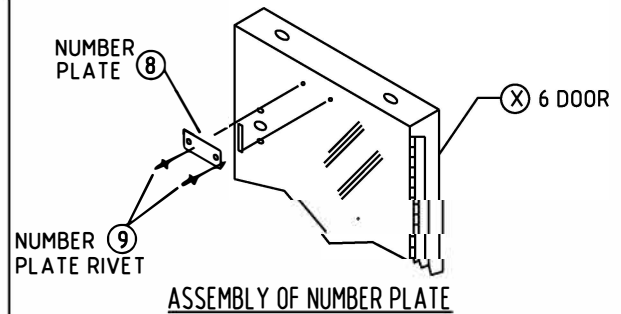

ASSEMBLY OF NUMBER PLATE

**HARDWARE USED FOR MAIN LOCKER ASSEMBLY**



10 - 24 x 3/8"

MBT200 SLOTLESS BOLT ⑫



N201 HEX NUT ⑬

TIGHTEN NUT WITH A NUT DRIVER OR WRENCH  
(SCREW IS TAMPER RESISTANT).

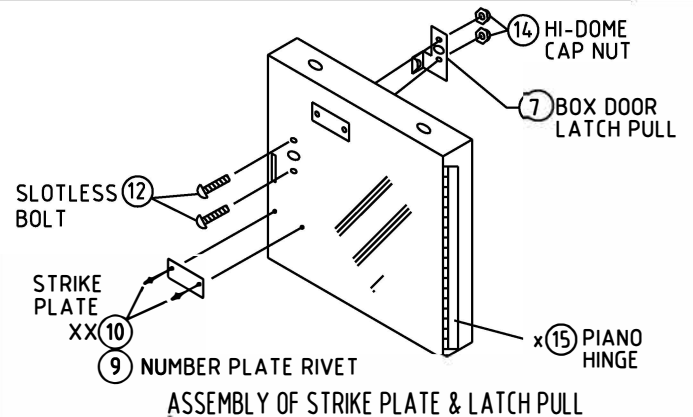

ASSEMBLY OF STRIKE PLATE & LATCH PULL

