

# Gear Locker Assembly Guide

## SMS-05-V65-6KF



### Fasteners & Tools Needed

The following items are found in the hardware kit shipped with the locker:

8615-Number plate



8671-Aluminum Rivet

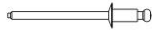

8676-Pop Rivet



8633-Screw 10-24 x 1/2"



8672-Nut 10-24



8702- Screw 10-24 x 3/8"



You will need these tools to assemble the Duty locker:

Rivet gun



Socket wrench

End wrench and drill or nut driver with 3/8" and 5/16" bits



Flat blade and Phillips head screwdrivers

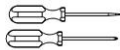

### STEP 1- Check Parts

Unpack the component pieces for the locker. You should have two sides, a back, a top, bottom, center shelf or (multiple shelves depending on the tier) and door & frame assembly for the locker body.

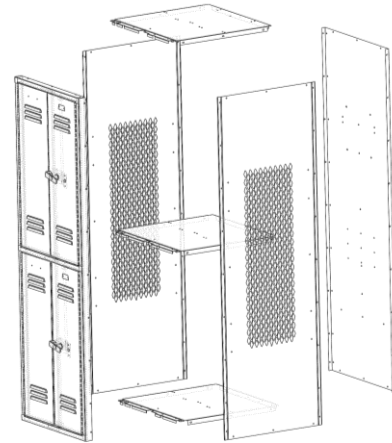

### STEP 2 - Assemble the locker

**2A-** With the back panel laying flat on the ground attach the sides to the back using 8633 screws and 8672 nuts. The side panels fit inside the flanges of the back panel as shown in the detail view below.

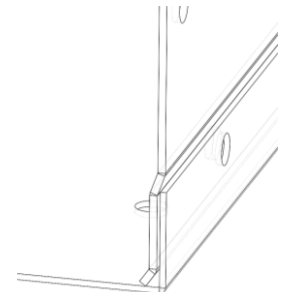
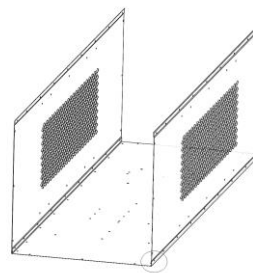

### 2B- Attach the top, bottom, and shelf pieces

The top, bottom and shelf fit inside the side panels as shown in the detail view below. Use 8633 bolts and 8672 nuts.

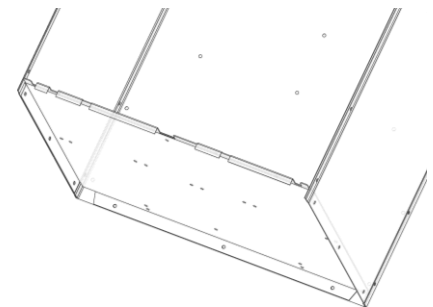
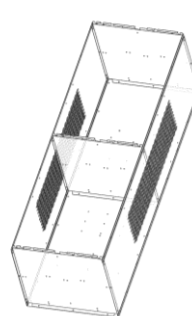

## 2C- Install the Door and Frame

The frame goes on the outside of the divisions as seen in the detail view. If unit is wider than 24" install the frame to locker body using 8633 screws and 8672 nuts and then attach the double doors using 8619 rivets. Note every hole in the continuous hinge should be filled with a rivet to the frame. If unit is 24" wide or less the door is already riveted to the frame and can be attached to the locker body using 8633 screws and 8672 bolts. Number plates will need to be riveted to the doors once the lockers are placed in the final positions to get the proper numbering sequence. Use 8671 rivets to attach number plates.

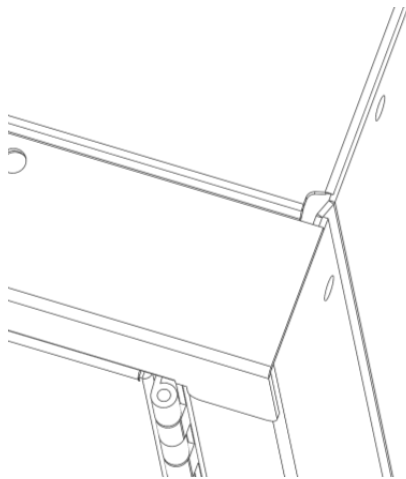

**Installation should now be complete.**

Other available variations or configurations

