

AUGMENTED REALITY SANDBOX

ASSEMBLY INSTRUCTIONS

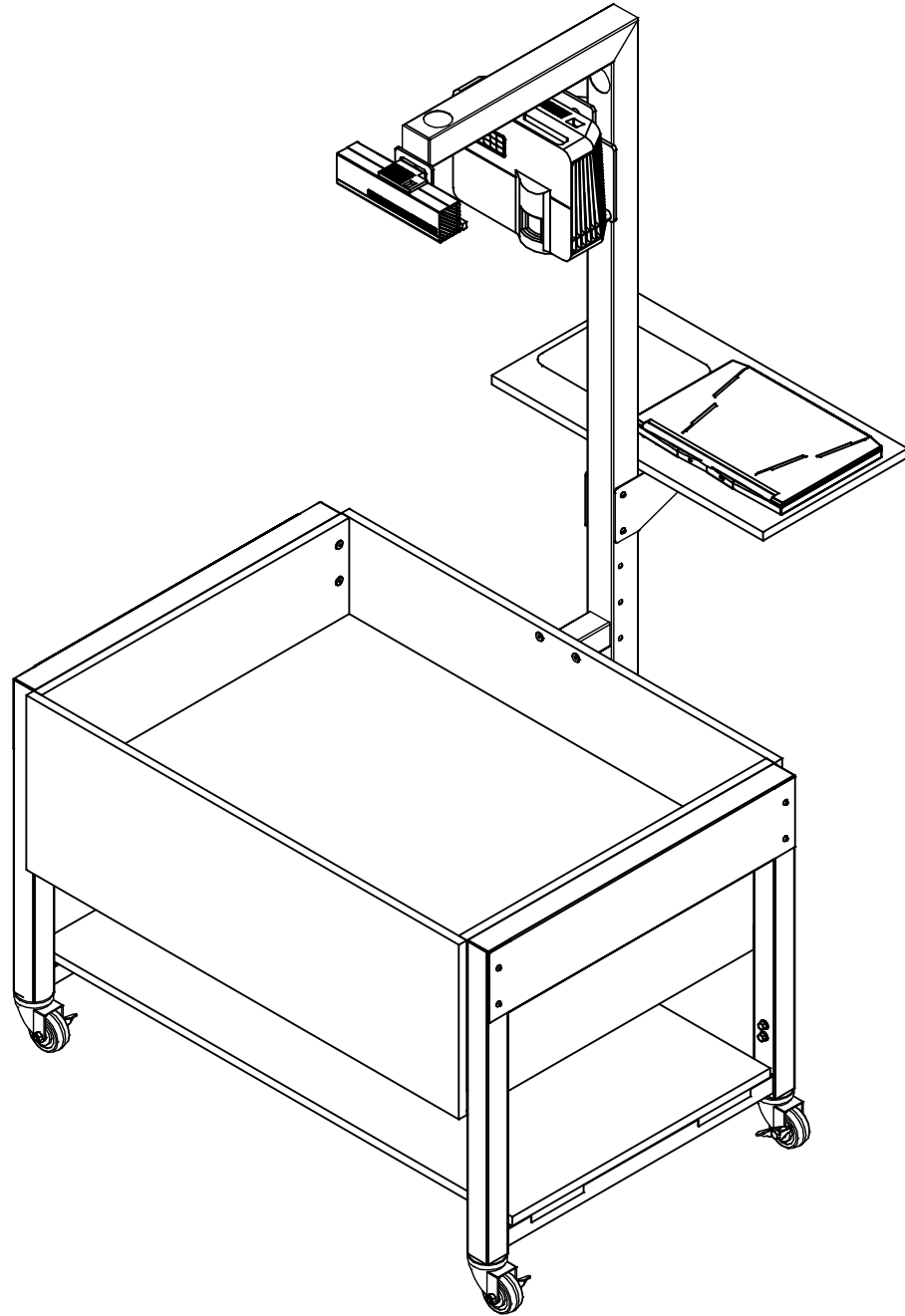

NOTE:

1. MODEL VIEWS MAY NOT REPRESENT EXACT MODEL PURCHASED



TOOLS REQUIRED

4MM ALLEN WRENCH
5MM ALLEN WRENCH
1/16" WRENCH
1/16" SOCKET AND TORQUE WRENCH - OPTIONAL
DRILL
1/8" DRILL BIT
PHILLIPS DRIVE DRILL BIT

ASSEMBLY COMPONENTS

ITEMS INCLUDED	PART #	PART DESCRIPTION	QTY
SANDBOX	N/A	ARS SANDBOX ASSEMBLY	1
ARM	259292-X	ARM,STEEL,ARS,4.50X20.19X63.11, <COLOR>,MATTE/SATIN	1
LEG ASSEMBLY	259294-X	LEG,STEEL,ARS,26.00X2.06X28.00, <COLOR>,MATTE/SATIN	2
LEG INSERT	255582-X	LEG,STEEL,ADJ INSERT,FAB-LAB, 1.75X1.75X18.00,<COLOR>,MATTE/SATIN	4
CASTERS	253996	UTILITY TABLE CASTERS	4
TUBE STRETCHER	259534-X	STRETCHER,STEEL,TUBE,<COLOR>, MATTE/SATIN	2
FORMED STRETCHER	259295-X	STRETCHER,STEEL,ARS,<COLOR>, MATTE/SATIN	2
LOWER SHELF	N/A	LOWER SHELF - 0.75"THK x 24.75"W x 45.50"L	1
LAPTOP SHELF BRACKET	259533-X	BRACKET,STEEL,ARS SHELF BRACKET,<COLOR>,MATTE/SATIN	1
LAPTOP SHELF	N/A	LAPTOP SHELF - 0.75"THK x 13.88"W x 26.00"L	1
CABLE TRAY	259296-X	BRACKET,STEEL,ARS UTILITY CABLE TRAY,<COLOR>,MATTE/SATIN	1
FRAME ASSEMBLY - BOLT	258473	BOLT,3/8-16X1 HEX HEAD	12
FRAME ASSEMBLY - WASHER	258471	WASHER,3/8" EXTERNAL TOOTH LOCK	12
CONNECTING BOLTS, LONG	259663	BOLT,1/4-20X2.50,CONNECTOR BOLT	10
CONNECTING BOLTS, SHORT	259537	BOLT,1/4-20X0.708,CONNECTOR BOLT	2

NOTE:

1. COMPONENTS VARY WITH STYLE OF UNIT PURCHASED
 - 1.1. METAL COMPONENT COLORS:
 - 1.1.1. BLACK, WHITE, CARROT, LIME, AQUA, SILVER, LIGHT GREY,
OR DARK GREY



ASSEMBLY COMPONENTS

ITEMS INCLUDED	PART #	PART DESCRIPTION	QTY
CONNECTING NUTS	234337-JCN	JOINT CONNECTING NUT,1/4-20X17MM	12
SHELF BRACKET TO ARM - BOLT	259666	SCREW,1/4-20X1/2 BUTTON HEAD HEX DRIVE	4
SHELF BRACKET TO SHELF - BOLT	235312	SCREW,1/4"-20 X 1 1/2" SLOTTED FLAT	4
SHELF BRACKET TO SHELF - NUT	100483	NUT,1/4-20 HEX ZINC	4
SCREWS - MISC	100111	SCREW,#8X5/8 TRUSS HEAD	10
THREADLOCKER	259680	VIBRA-TITE,THREADLOCKER,BLUE,1.8ML	1

NOTE:

1. COMPONENTS VARY WITH STYLE OF UNIT PURCHASED
 - 1.1. METAL COMPONENT COLORS:
 - 1.1.1. BLACK, WHITE, CARROT, LIME, AQUA, SILVER, LIGHT GREY, OR DARK GREY



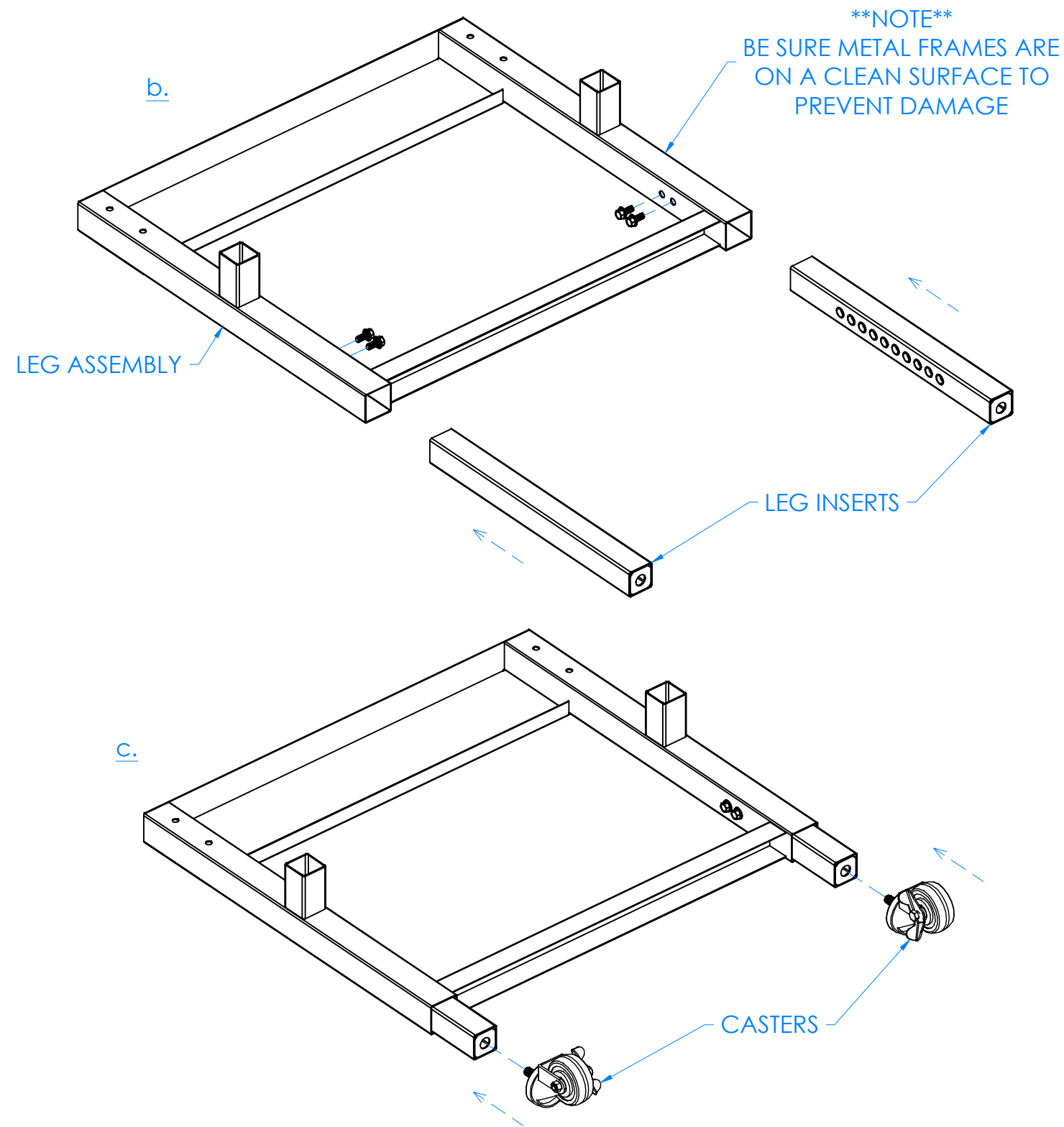

HARDWARE REQUIRED FOR STEP

QTY	DESCRIPTION	PART NUMBER
2	LEG ASSEMBLY	259294-X
4	LEG INSERT	255582-X
4	CASTERS	253996
8	FRAME ASSEMBLY - BOLT	258473
8	FRAME ASSEMBLY - WASHER	258471
1	THREADLOCKER	259680

STEP 1:

- a. LAY LEG ASSEMBLY ONTO CLEAN, FLAT SURFACE.
- b. INSERT AND SECURE LEG INSERTS USING PROVIDED BOLTS AND WASHERS LISTED ABOVE.
- c. APPLY VIBRA-TITE THREADLOCKER TO CASTERS AND ATTACH CASTERS TO LEG INSERTS.
- d. PLACE TO THE SIDE AND REPEAT WITH OTHER LEG ASSEMBLY.

NOTE:

1. OVERALL HEIGHT CAN BE ADJUSTED TO DESIRED HEIGHT AS NEEDED.
2. ONLY ADJUST OVERALL HEIGHT OF UNIT WITH SANDBOX EMPTY.
DO NOT ATTEMPT TO ADJUST HEIGHT WITH SAND IN SANDBOX!



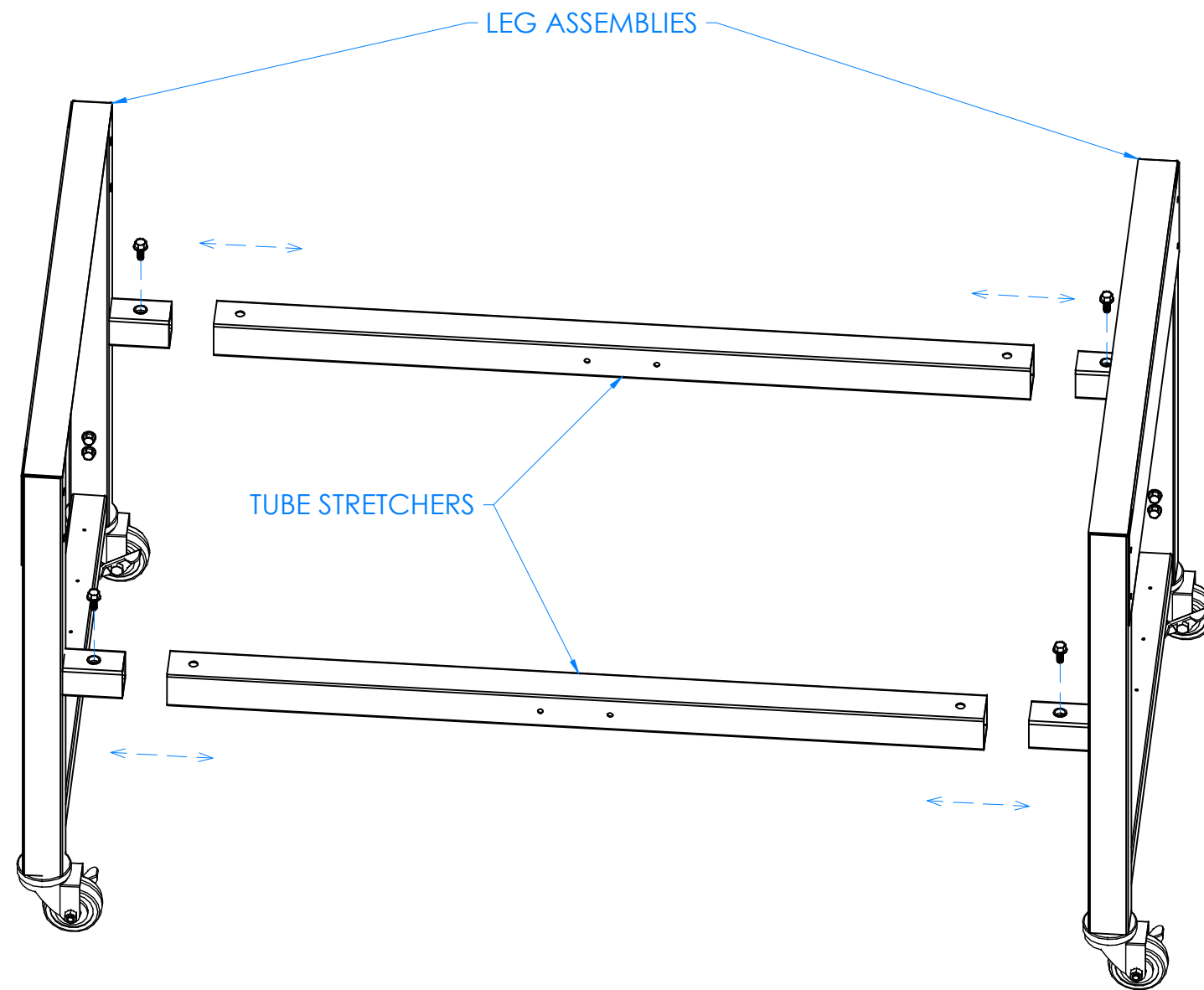

HARDWARE REQUIRED FOR STEP

QTY	DESCRIPTION	PART NUMBER
2	TUBE STRETCHER	259534-X
4	BOLT - FRAME ASSEMBLY	258473
4	WASHER - FRAME ASSEMBLY	258471

STEP 2:

- a. ASSEMBLE METAL FRAME ASSEMBLY BY SLIDING TUBE STRETCHERS ONTO THE LEG ASSEMBLY TUBES.
- b. USING PROVIDED HARDWARE LISTED ABOVE, BOLT THROUGH TUBE STRETCHERS INTO RIVET NUTS LOCATED ON LEG ASSEMBLIES.



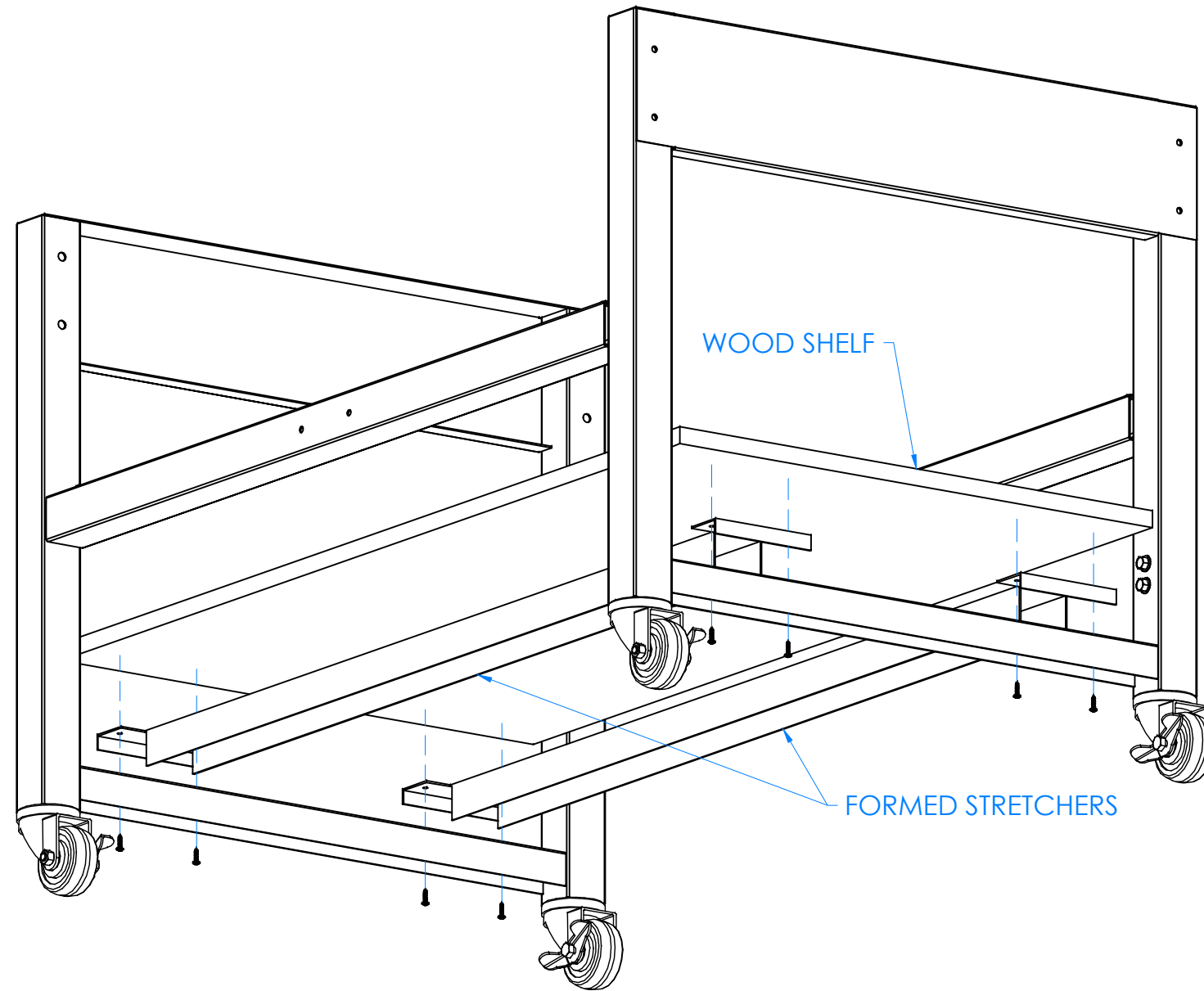

HARDWARE REQUIRED FOR STEP

QTY	DESCRIPTION	PART NUMBER
1	LOWER SHELF	N/A
2	FORMED STRETCHER	259295-X
8	SCREWS - MISC	100111

STEP 3:

- a. PLACE STRETCHERS ONTO BOTTOM FORMED CHANNELS ALIGNED WITH THE TWO OUTSIDE SETS OF HOLES.
- b. SET SHELF ONTO STRETCHERS AND MEASURE FOR EVEN SPACING AND OVERHANG.
- c. PREDRILL PILOT HOLES INTO WOOD SHELF.
- d. ATTACH LOWER SHELF BY SCREWING INTO SHELF THROUGH BOTH STRETCHER AND FORMED CHANNEL USING PROVIDED HARDWARE LISTED ABOVE.



HARDWARE REQUIRED FOR STEP

QTY	DESCRIPTION	PART NUMBER
1	SANDBOX	N/A
8	CONNECTING BOLT, LONG	259663
8	CONNECTING NUTS	234337-JCN

STEP 4:

- a. SLIDE AND DROP SANDBOX DOWN ONTO TUBE STRETCHERS.
- b. FASTEN SANDBOX TO LEGS USING PROVIDED HARDWARE LISTED ABOVE.
 - b.a. FASTEN WITH CONNECTING NUTS LOCATED ON INSIDE OF SANDBOX AND CONNECTING BOLTS ON OUTSIDE OF SANDBOX, LIKE SHOWN.

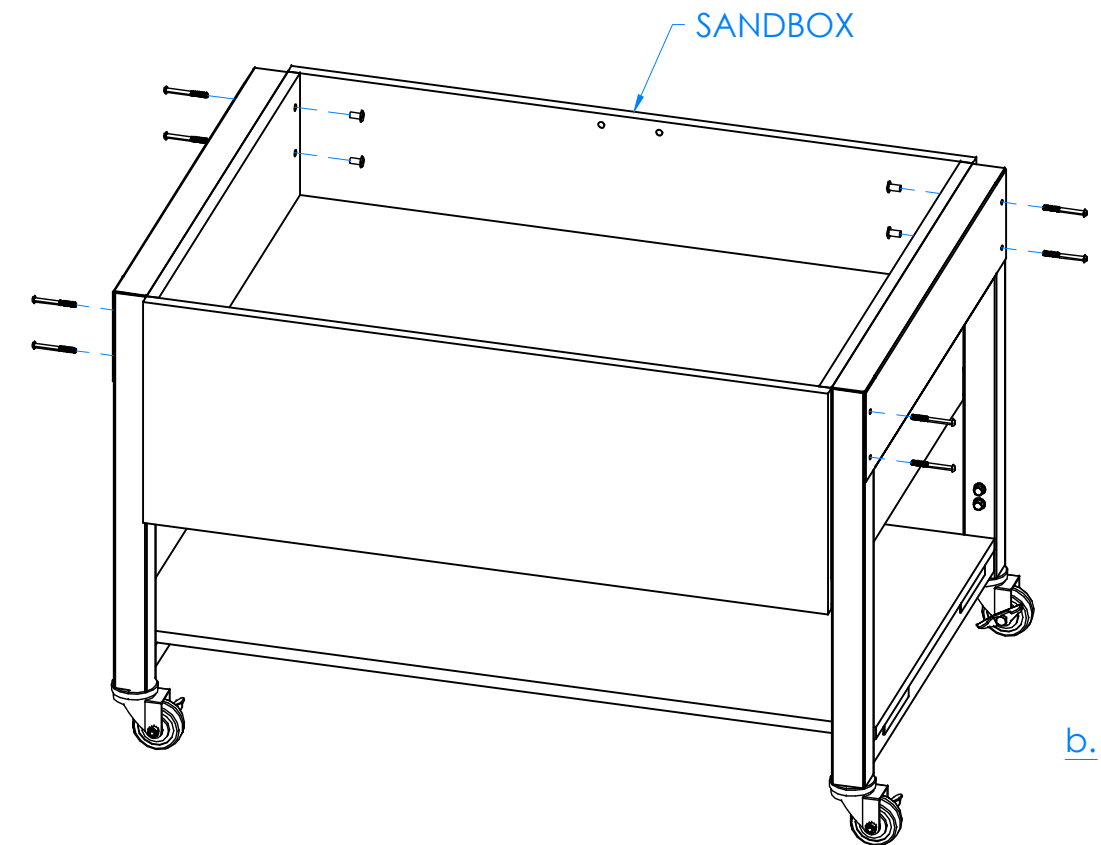
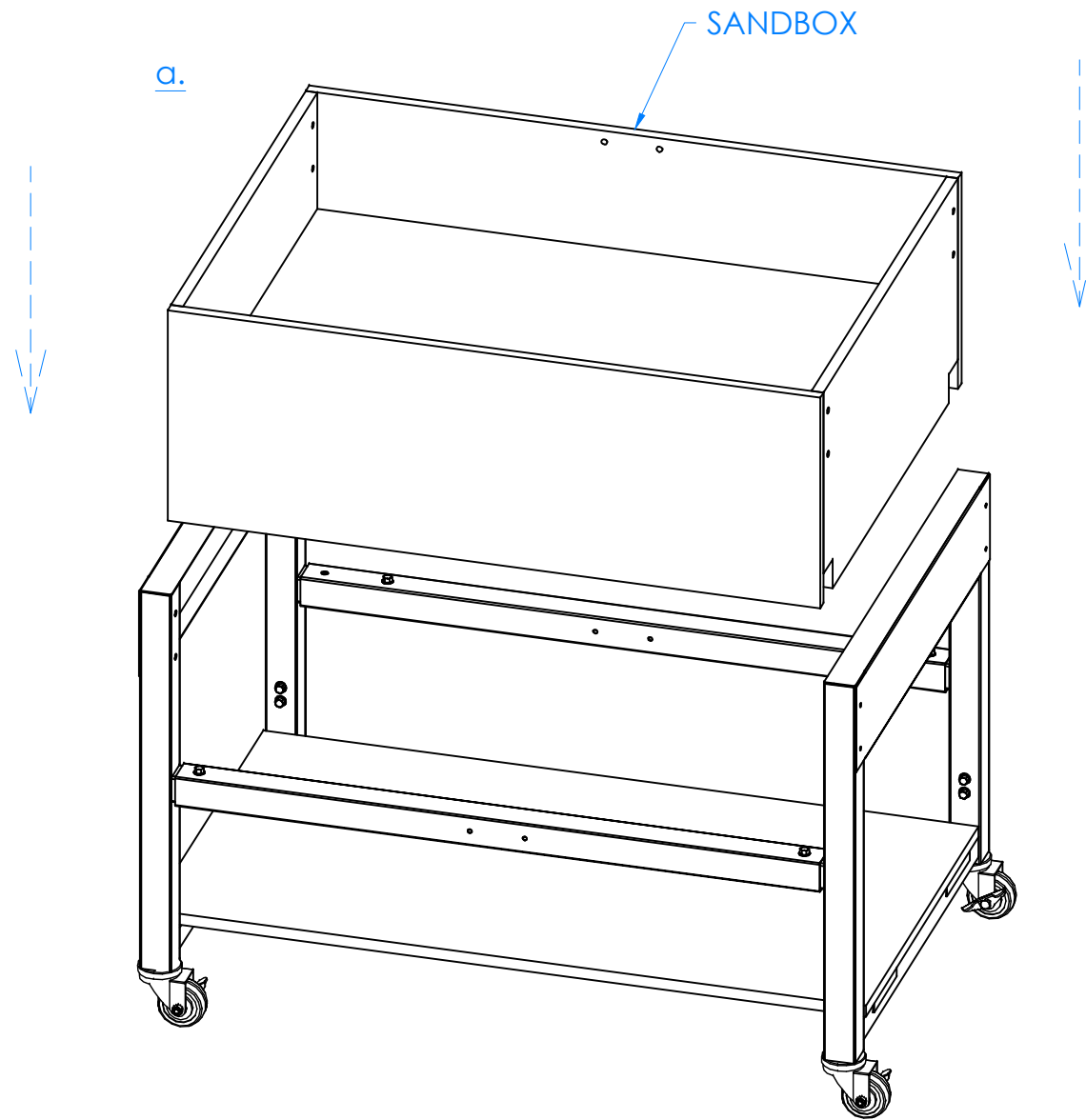

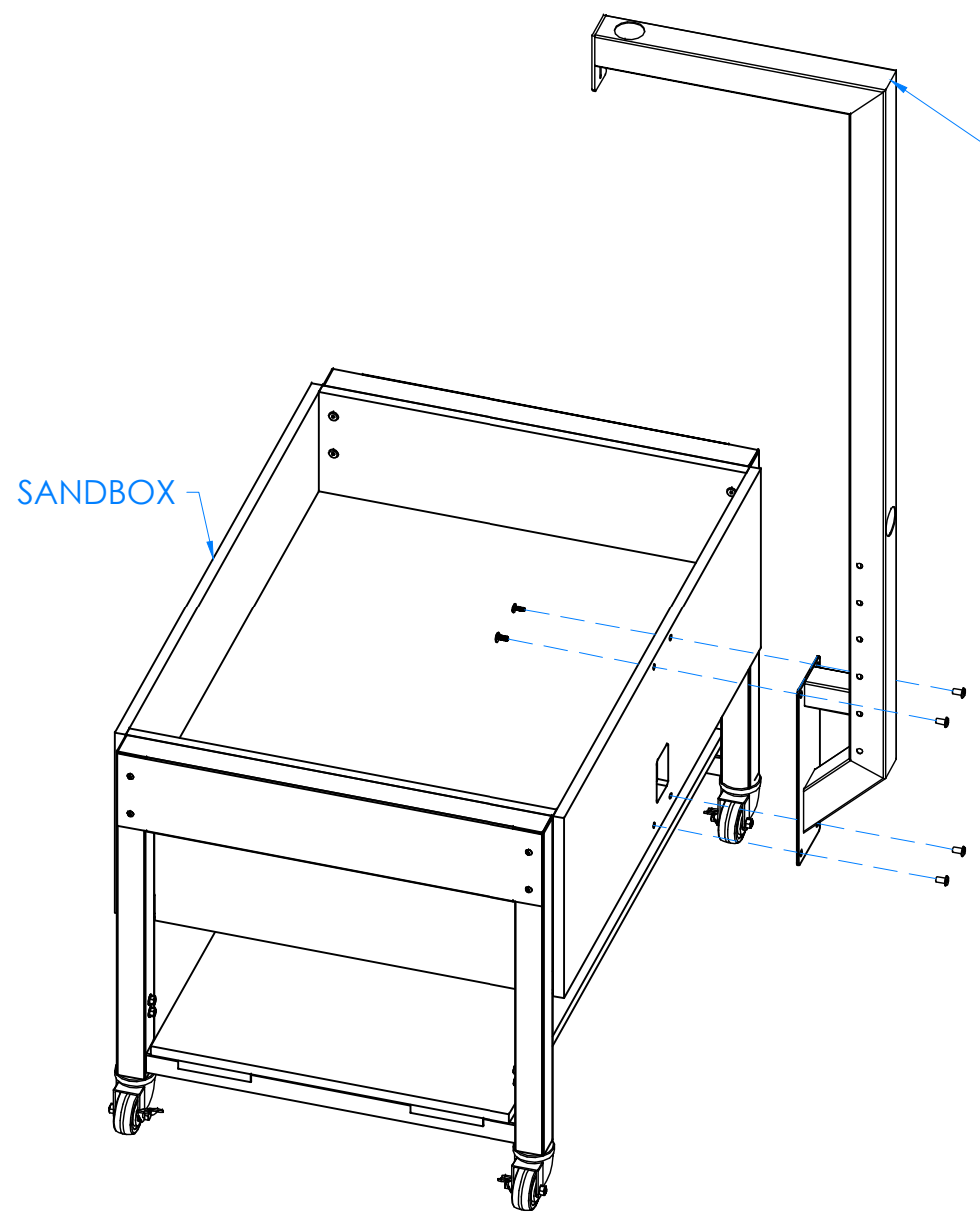

SANDBOX

ARM

SANDBOX

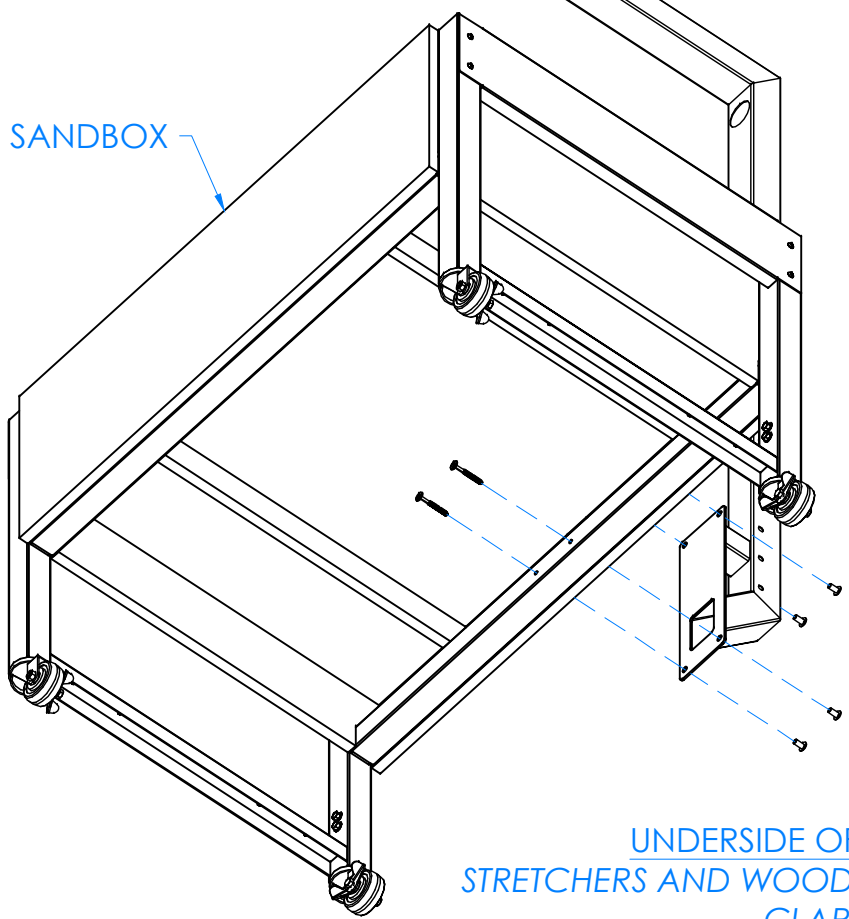

UNDERSIDE OF SANDBOX
STRETCHERS AND WOOD SHELF REMOVED FOR
CLARITY

HARDWARE REQUIRED FOR STEP

QTY	DESCRIPTION	PART NUMBER
1	ARM	259292-X
4	CONNECTING NUTS	234337-JCN
2	CONNECTING BOLTS,SHORT	259537
2	CONNECTING BOLT,LONG	259663

STEP 5:

- a. ATTACH ARM TO BACK OF SANDBOX USING PROVIDED HARDWARE LISTED ABOVE.
 - a.a. USE SHORT CONNECTING BOLTS FOR THE UPPER HOLES AND THE LONG CONNECTION BOLTS FOR THE LOWER HOLES.
 - a.b. FASTEN WITH CONNECTING NUTS LOCATED ON OUTSIDE OF SANDBOX AND CONNECTING BOLTS ON INSIDE OF SANDBOX, LIKE SHOWN.



HARDWARE REQUIRED FOR STEP

QTY	DESCRIPTION	PART NUMBER
1	CABLE TRAY	259296-X
2	SCREW, #8X5/8 TRUSS HEAD	100111

STEP 6:

- a. ATTACH CABLE TRAY TO UNDERSIDE OF SANDBOX USING PROVIDED HARDWARE LISTED ABOVE.
- a.a. PREDRILL HOLES AND ATTACH AS CLOSE AS POSSIBLE TO BACK TUBE STRETCHER WHILE MAINTAINING ENOUGH ROOM TO REACH UP INTO CABLE TRAY (ABOUT 2 1/2" AWAY FROM EDGE OF TUBE STRETCHER).

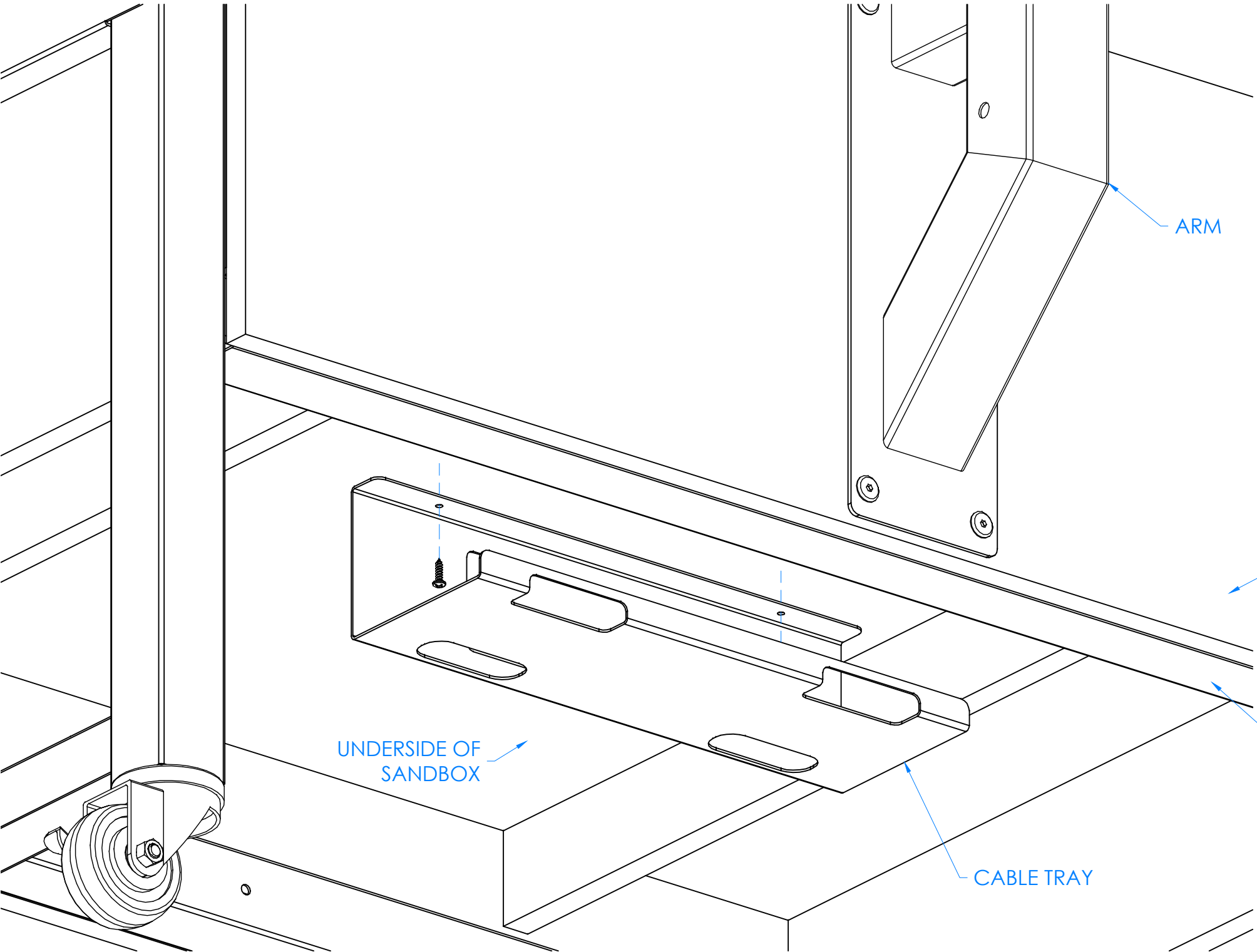

UNDERSIDE OF SANDBOX
STRETCHERS AND WOOD SHELF REMOVED FOR CLARITY



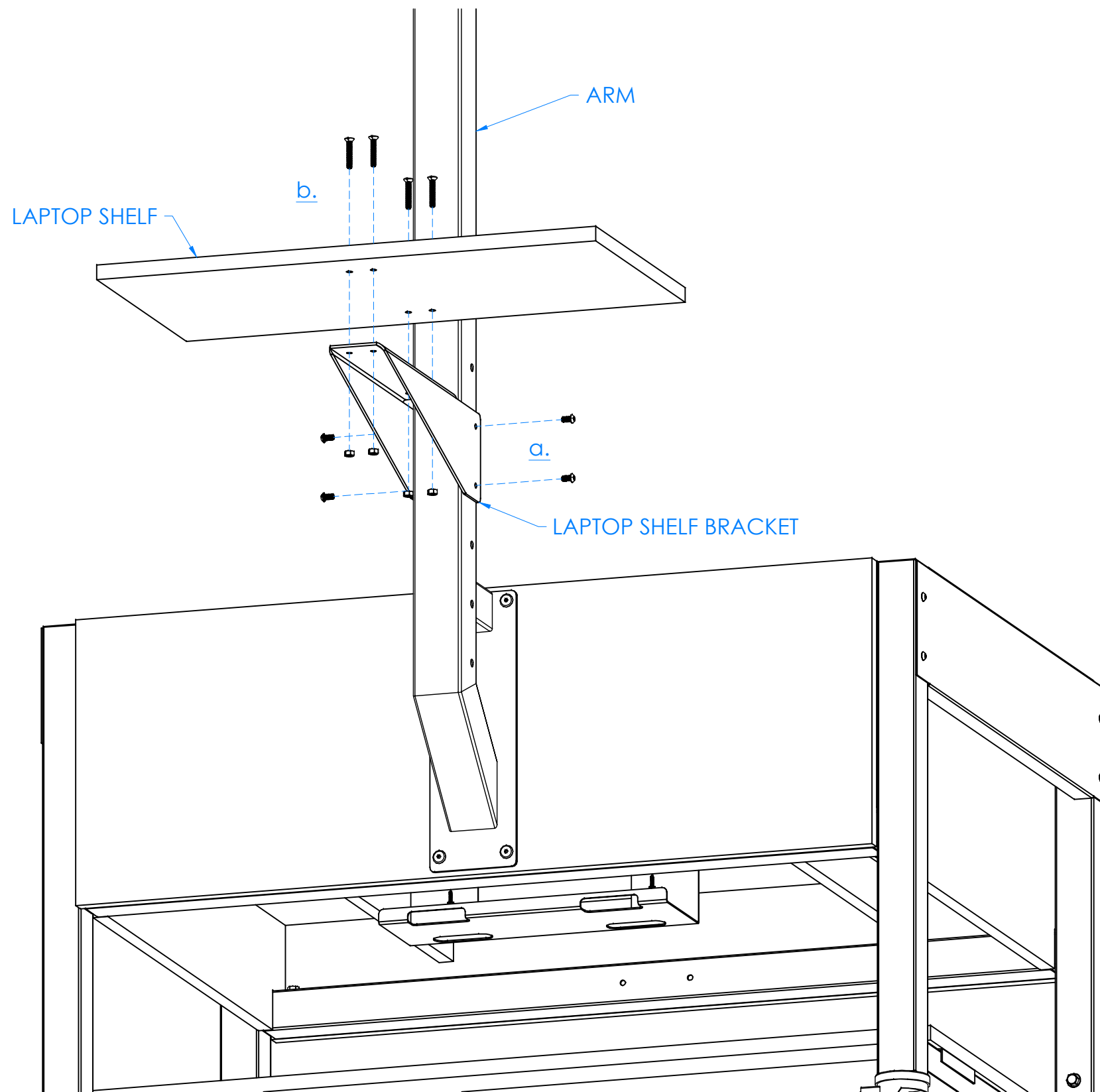

HARDWARE REQUIRED FOR STEP

QTY	DESCRIPTION	PART NUMBER
1	LAPTOP SHELF BRACKET	259533-X
1	LAPTOP SHELF	N/A
4	SHELF BRACKET TO ARM - BOLT	259666
4	SHELF BRACKET TO SHELF - BOLT	235312
4	SHELF BRACKET TO SHELF - NUT	100483

STEP 7:

- a. ATTACH ADJUSTABLE SHELF BRACKET TO ARM USING PROVIDED BOLTS LISTED ABOVE.
 - a.a. CAN USE ANY OF THE SETS OF HOLES IN THE SIDES OF THE ARM IN ORDER TO SET TO DESIRED HEIGHT.
- b. ATTACH LAPTOP SHELF ONTO ADJUSTABLE SHELF BRACKET WITH THE PROVIDED FLAT HEAD BOLTS AND NUTS LISTED ABOVE.
 - b.a. TIGHTEN FLAT HEAD BOLTS UNTIL THE HEAD OF THE BOLTS ARE FLUSH WITH TOP OF LAPTOP SHELF.

NOTE:

1. LAPTOP SHELF CAN BE ADJUSTED BY REMOVING SHELF BRACKET TO ARM BOLTS AND REATTACHING TO ANY SET OF RIVET NUTS LOCATED ON THE SIDES OF THE ARM.



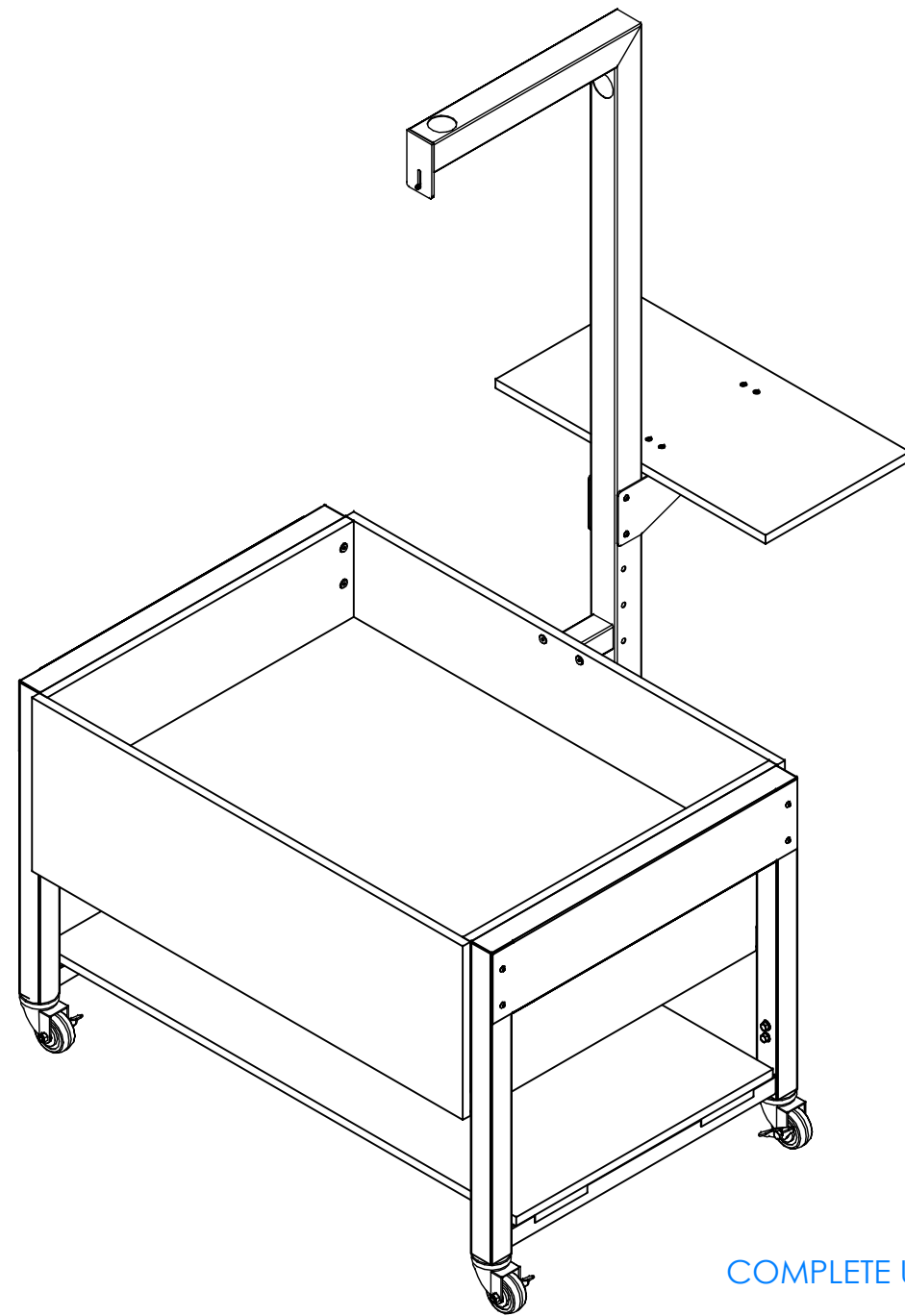

COMPLETE UNIT SHOWN

STEP 8:

- a. FILL SANDBOX WITH SAND (**NOT SUPPLIED BY DWI**).
- a.a. FILL SANDBOX AT LEAST HALFWAY FULL. RECOMMEND USING SANDTASTIK THERAPY SAND. HOWEVER, ANY DRY, WHITE SAND WILL WORK. APPROXIMATELY 200-250 LBS.
- b. POSITION COMPLETED UNIT IN DESIRED LOCATION.
- c. SEE NOTES FOR ADDITIONAL INFORMATION.

NOTE:

1. FOR INSTRUCTIONS FOR INSTALLING ELECTRICAL COMPONENTS TO UNIT, SEE "ARS - ELECTRONICS".
2. FOR INSTRUCTIONS TO SET UP ARS SOFTWARE, SEE "ARS - USER'S GUIDE FOR SET UP AND CALIBRATION(WINDOWS 11)".
3. ONLY ADJUST OVERALL HEIGHT OF UNIT WITH SANDBOX EMPTY.
DO NOT ATTEMPT TO ADJUST HEIGHT WITH SAND IN SANDBOX!

