

# Cantilever Cart Assembly Guide

## SMS-02-V80-CSC

15A

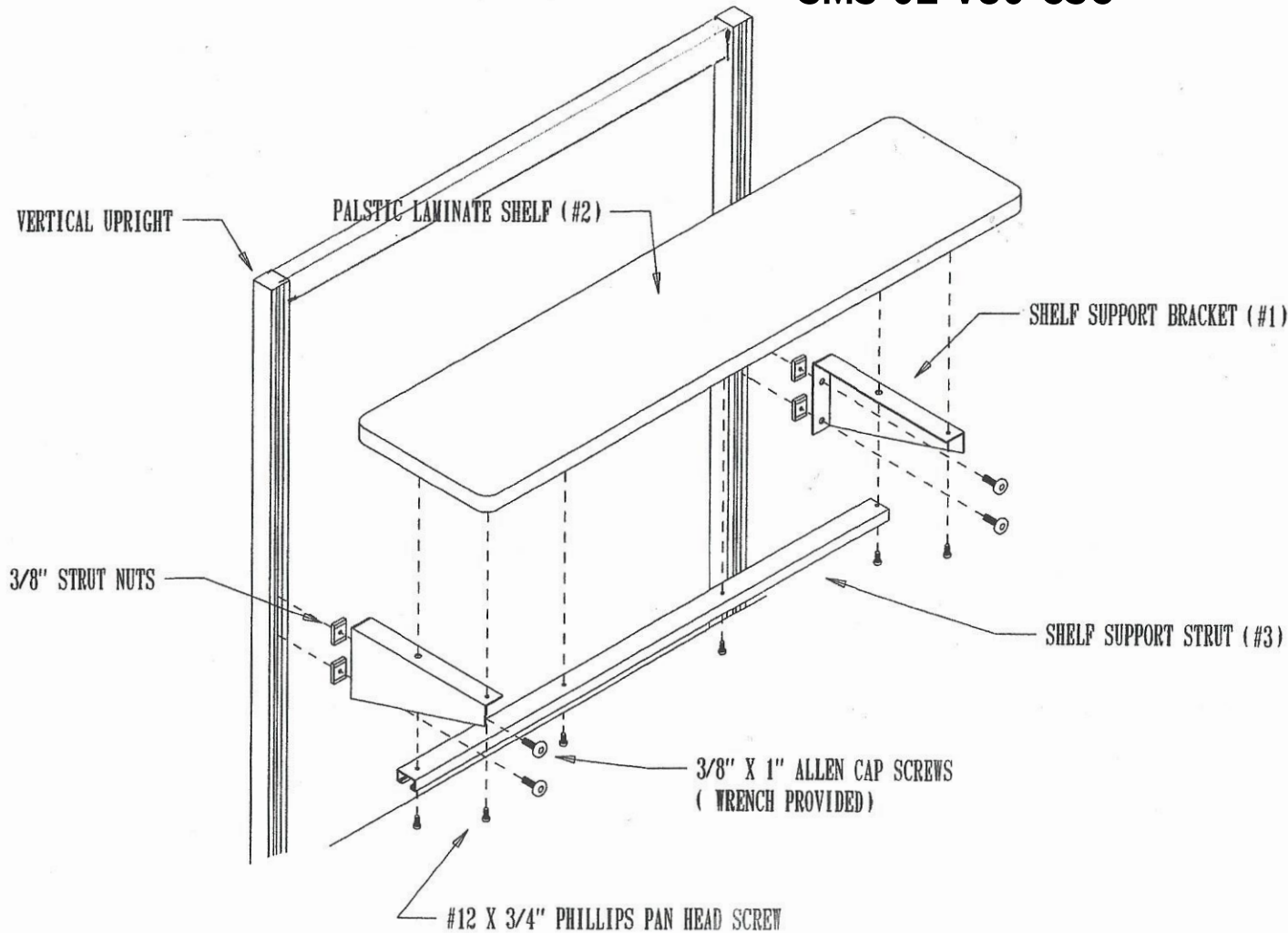

### TOOLS REQUIRED:

1 SCREW GUN WITH #3 PHILIPS HEAD TIP  
7/32" WRENCH

- 1) CHOOSE DESIRED HEIGHT ON UPRIGHTS AND MOUNT SHELF BRACKETS TO THE UPRIGHTS WITH 3/8" X 1" ALLEN CAP BOLTS AND STRUT NUTS PROVIDED
- 2) LAY PLASTIC LAMINATED SHELF ACROSS SHELF SUPPORT BRACKETS WITH EQUAL OVERHANG ON LEFT AND RIGHT SIDES
- 3) WITH 2 PEOPLE (ONE ON EACH SIDE OF SHELF), HOLD SHELF SUPPORT STRUT AGAINST SHELF SUPPORT BRACKETS AND INSTALL #12 X 3/4" PHILLIPS PAN HEAD SCREWS IN EACH END. THEN PROCEED TO INSTALL THE REMAINDER OF THE PAN HEAD SCREWS



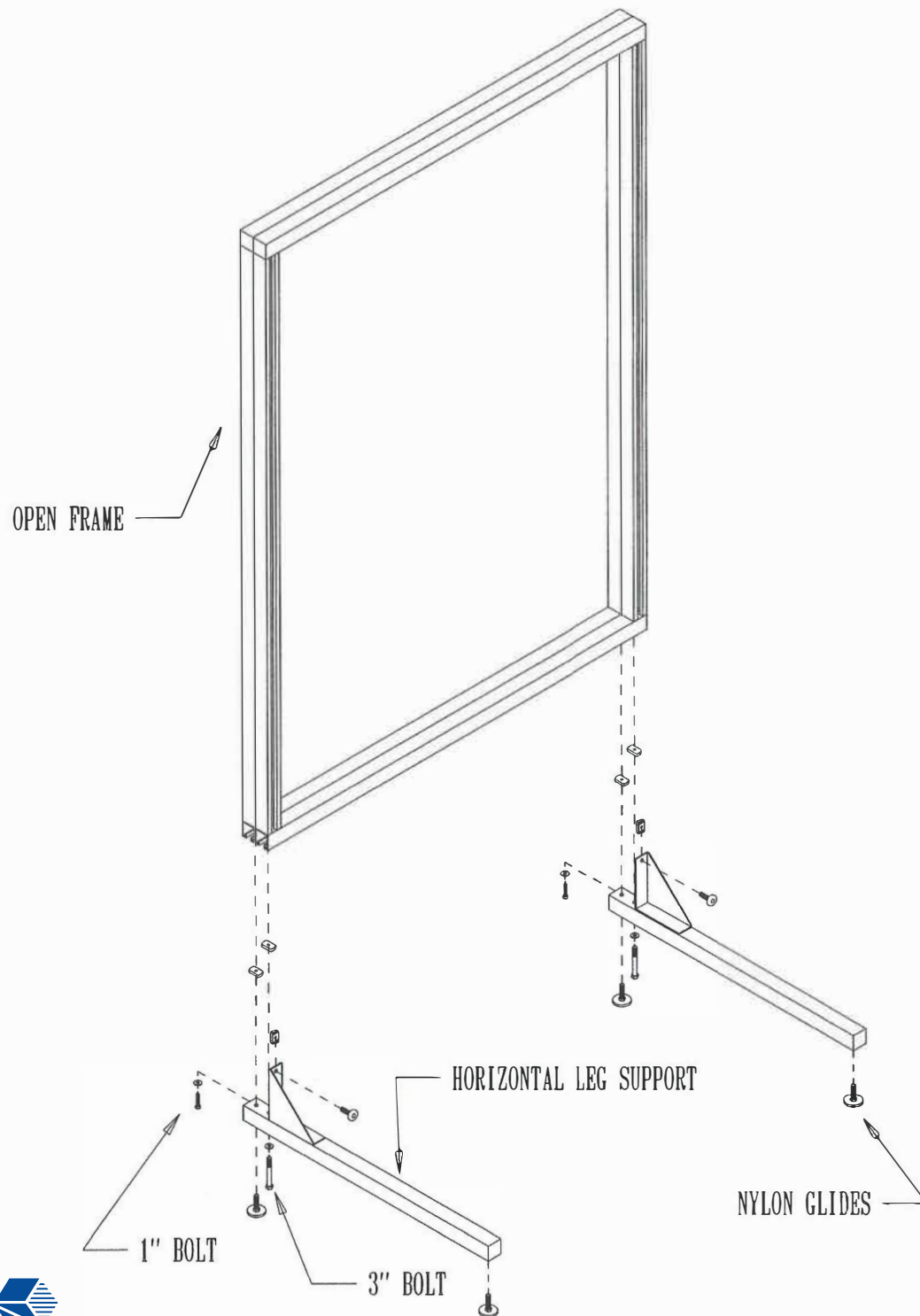

- 1) SCREW NYLON GLIDES INTO THE BOTTOM OF THE HORIZONTAL LEG SUPPORT
- 2) MOUNT OPEN FRAME TO THE HORIZONTAL LEG SUPPORT USING (1) 3/8" X 16 X 3" HEX HEAD BOLT, 3/8" FLAT WASHER AND STRUT NUT. (1) 3/8" X 1" HEX HEAD BOLT, WASHER AND STRUT NUT FOR EACH LEG; DO NOT TIGHTEN  
NOTE : THE 1" BOLT AND WASHER GO INSIDE THE SQUARE TUBE THEN UP INTO THE OPEN FRAME NUT
- 3) MOUNT OPEN FRAME TO ANGLE GUSSETS BY PUTTING THE 3/8" X 1" ALLEN HEAD SCREW INTO THE HOLE LOCATED ON THE ANGLE GUSSET AND SLIDING THE STRUT NUT INTO THE OPEN FRAME CHANNEL AND TIGHTEN.
- 4) TIGHTEN ALL OTHER SCREWS

