

# Compact Rolling Oak Storage Cabinet with Locking Doors

## SMS-01-V102

4101, 4401, 4741, 4751, 4701, 4901, 5201, & 5301 SERIES (OAK OR MAPLE)  
ASSEMBLY INSTRUCTIONS

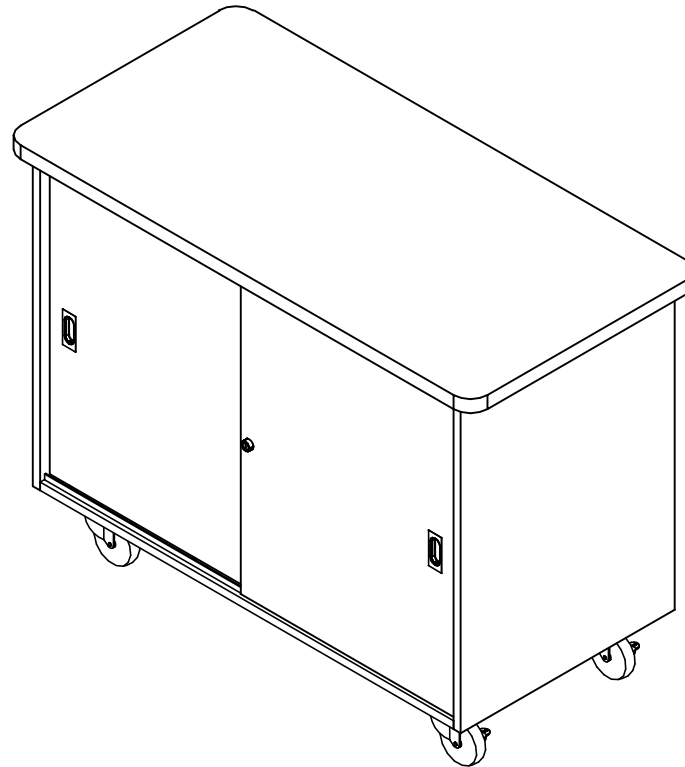

NOTE:

1. MODEL VIEWS MAY NOT REPRESENT EXACT MODEL PURCHASED

### TOOLS REQUIRED

1/2" WRENCH
ADJUSTABLE PLIERS
SCREW DRIVER

### ASSEMBLY COMPONENTS

ITEMS INCLUDED	PART #	PART DESCRIPTION	QTY
CASTERS	100081	CASTER,4IN SWIVEL TOP PLATE, W/BRAKE	4
CASTER HARDWARE KIT	206509	CASTER,ASSY,HDWRE,16-SCREWS, 16-NUTS	1
**SHELF CLIPS**	100027	SHELF CLIPS,PLASTIC,5MM PIN	VARIES
**TOTES**	100135	TOTE TRAY, T-188	VARIES
**MICROSCOPE DIVIDERS**	100995	MICROSCOPE DIVIDER,ZINC	VARIES

NOTE:

1. COMPONENTS VARY WITH STYLE OF MOBILE CABINET PURCHASED.
2. **\*\*XX\*\*** INDICATES ITEMS THAT MAY NOT COME WITH UNIT (DEPENDING ON MODEL PURCHASED).



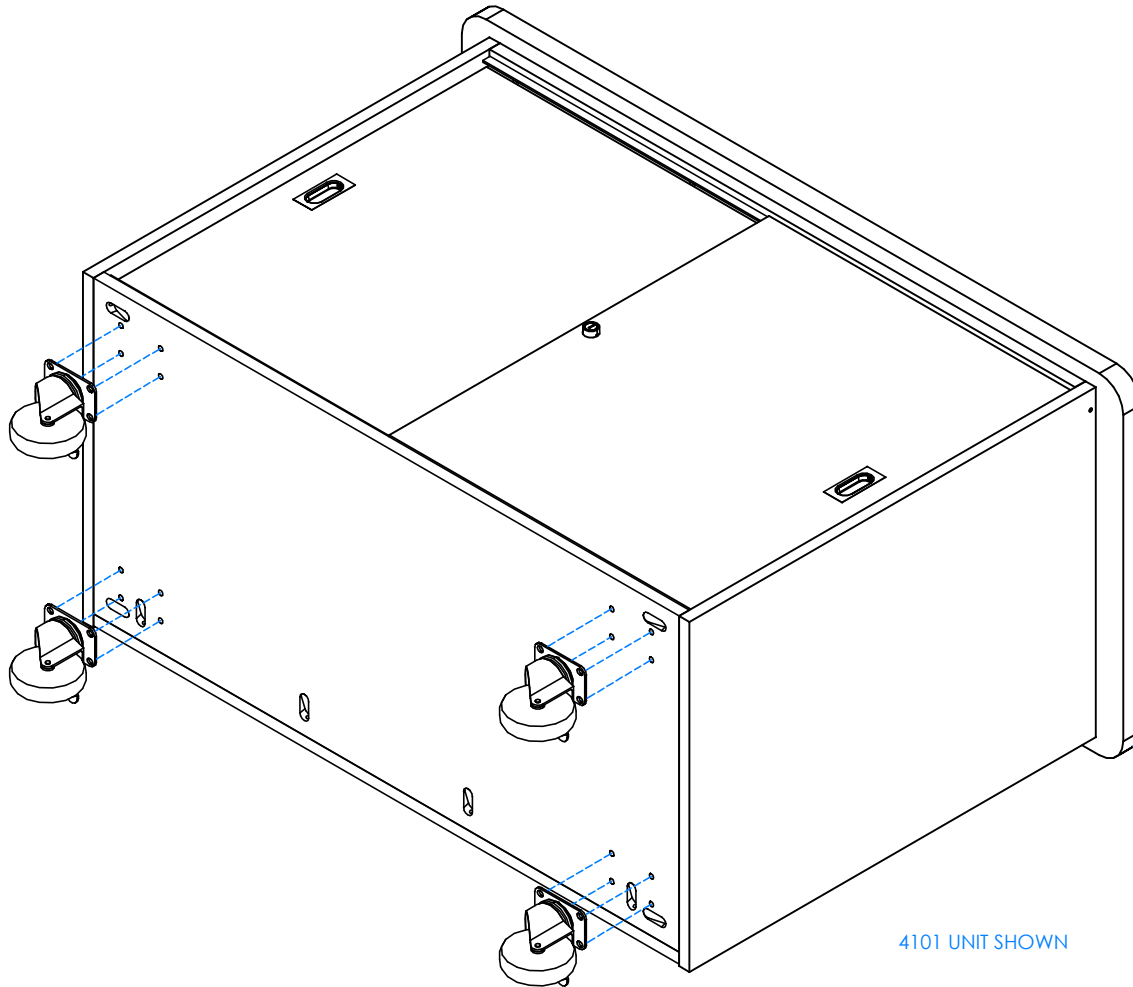

STEP 1:

- IF YOUR CABINET COMES WITH AN APPLIED BOTTOM SKIP TO STEP 2.
- IF YOUR CABINET COMES WITH CASTERS INSTALLED, SKIP TO STEP 3.
- LAY CABINET ON ITS BACK.
- ATTACH CASTERS FROM INSIDE CABINET USING HARDWARE PROVIDED.

**\*\*NOTE\*\***  
BE SURE CABINET IS ON  
A CLEAN SURFACE TO  
PREVENT DAMAGE

4101 UNIT SHOWN

NOTE:

1. TO REMOVE SLIDING DOORS - SLIDE DOORS TO ONE SIDE. REMOVE EXPOSED SCREWS FROM TOP RAIL. SLIDE DOORS TO OPPOSITE SIDE AND REMOVE REMAINING SCREWS. TILT DOORS AND RAIL OUT. REPEAT STEPS ABOVE IN REVERSE TO PUT DOORS BACK ON.



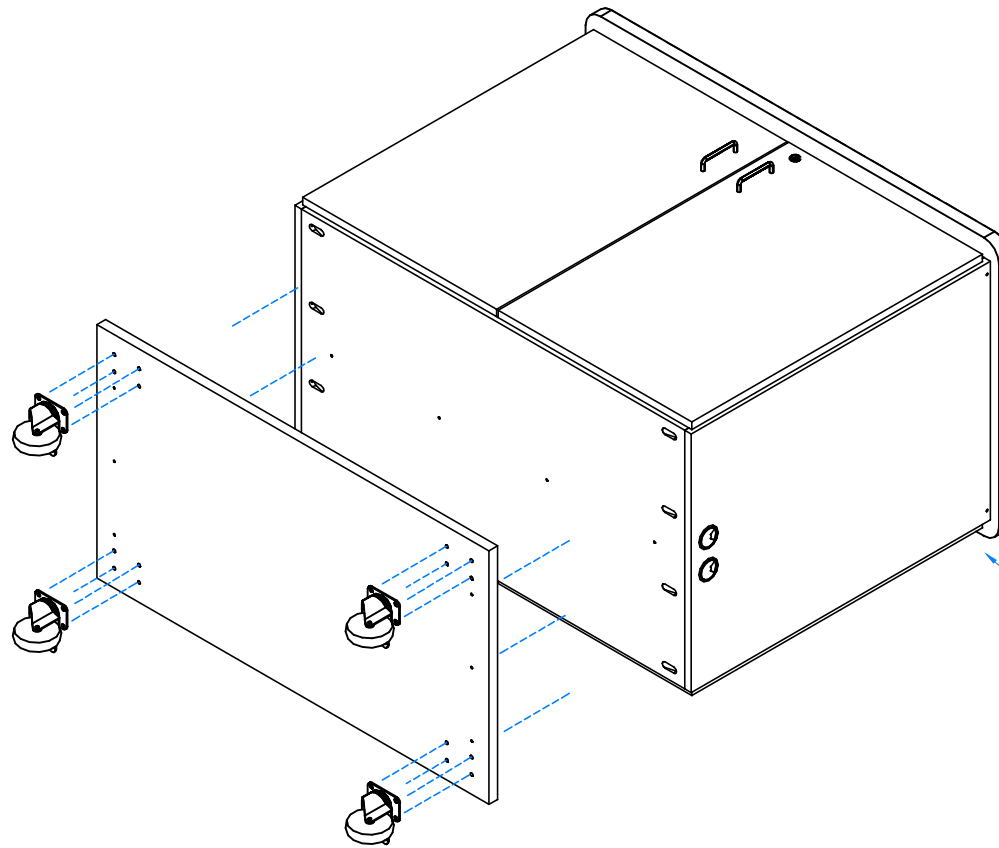

STEP 1:

- IF YOUR CABINET COMES WITH CASTERS INSTALLED, SKIP TO STEP 3.
- LAY CABINET ON ITS BACK.
- IF CABINET COMES WITH AN APPLIED BOTTOM ATTACH CASTERS TO APPLIED BOTTOM.
- THEN ATTACH APPLIED BOTTOM TO CABINET USING THE LOCATOR HOLES AND SCREWS SUPPLIED.

**\*\*NOTE\*\***  
BE SURE CABINET IS ON  
A CLEAN SURFACE TO  
PREVENT DAMAGE

4741 UNIT SHOWN

NOTE:

1. TO REMOVE SLIDING DOORS - SLIDE DOORS TO ONE SIDE. REMOVE EXPOSED SCREWS FROM TOP RAIL. SLIDE DOORS TO OPPOSITE SIDE AND REMOVE REMAINING SCREWS. TILT DOORS AND RAIL OUT. REPEAT STEPS ABOVE IN REVERSE TO PUT DOORS BACK ON.



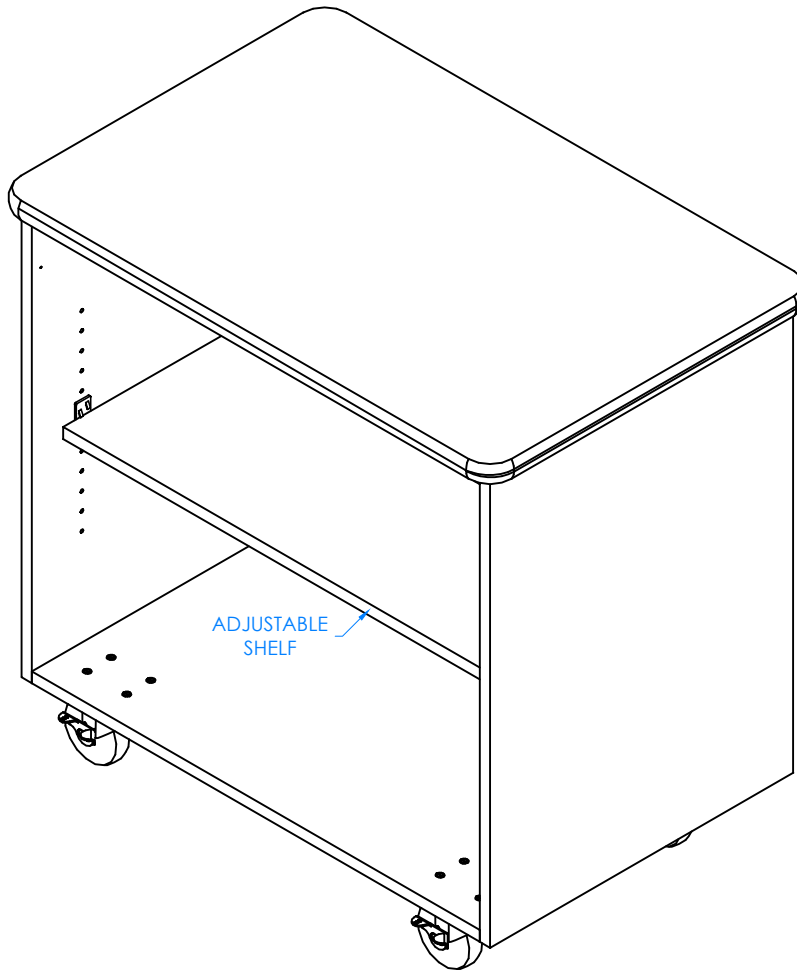

STEP 3

- TIP CABINET UP.
- IF YOUR UNIT DOES NOT HAVE AN ADJUSTABLE SHELF, SKIP TO STEP 4.
- INSERT SHELF CLIPS IN DESIRED LOCATION.
- PLACE SHELF ON CLIPS, MAKING SURE IT IS LEVEL.

4401 UNIT SHOWN WITH ADJUSTABLE SHELF  
DOORS AND HARDWARE REMOVED TO  
SHOW CLARITY

NOTE:

1. TO REMOVE SLIDING DOORS - SLIDE DOORS TO ONE SIDE. REMOVE EXPOSED SCREWS FROM TOP RAIL. SLIDE DOORS TO OPPOSITE SIDE AND REMOVE REMAINING SCREWS. TILT DOORS AND RAIL OUT. REPEAT STEPS ABOVE IN REVERSE TO PUT DOORS BACK ON.



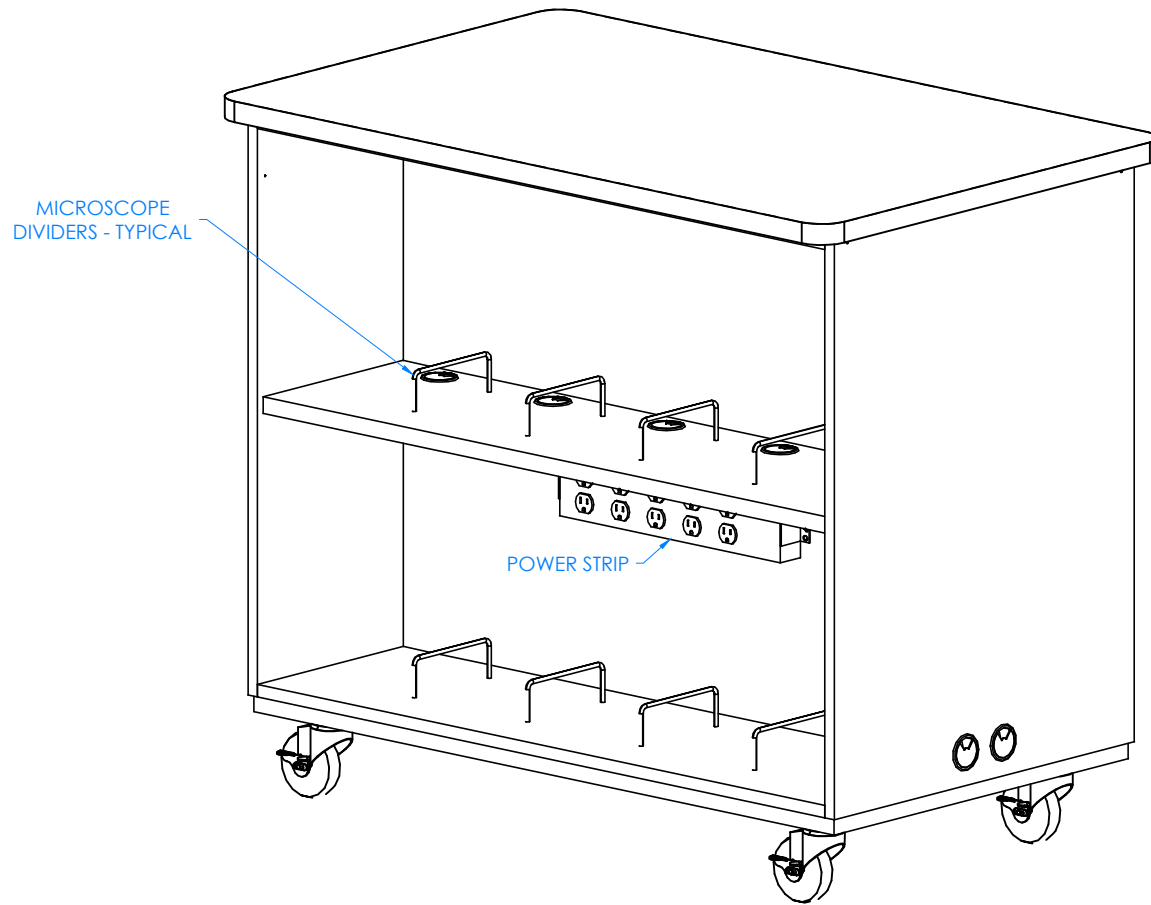

STEP 4:

- IF YOUR UNIT DOES NOT HAVE MICROSCOPE DIVIDERS, SKIP TO STEP 5.
- ATTACH MICROSCOPE DIVIDERS TO SHELF.
- PLUG IN POWER STRIP TO OUTLET (4741).

4741 UNIT SHOWN WITH MICROSCOPE DIVIDERS  
DOORS AND HARDWARE REMOVED TO SHOW  
CLARITY

NOTE:

1. TO REMOVE SLIDING DOORS - SLIDE DOORS TO ONE SIDE. REMOVE EXPOSED SCREWS FROM TOP RAIL. SLIDE DOORS TO OPPOSITE SIDE AND REMOVE REMAINING SCREWS. TILT DOORS AND RAIL OUT. REPEAT STEPS ABOVE IN REVERSE TO PUT DOORS BACK ON.



TOTE TRAYS - TYPICAL

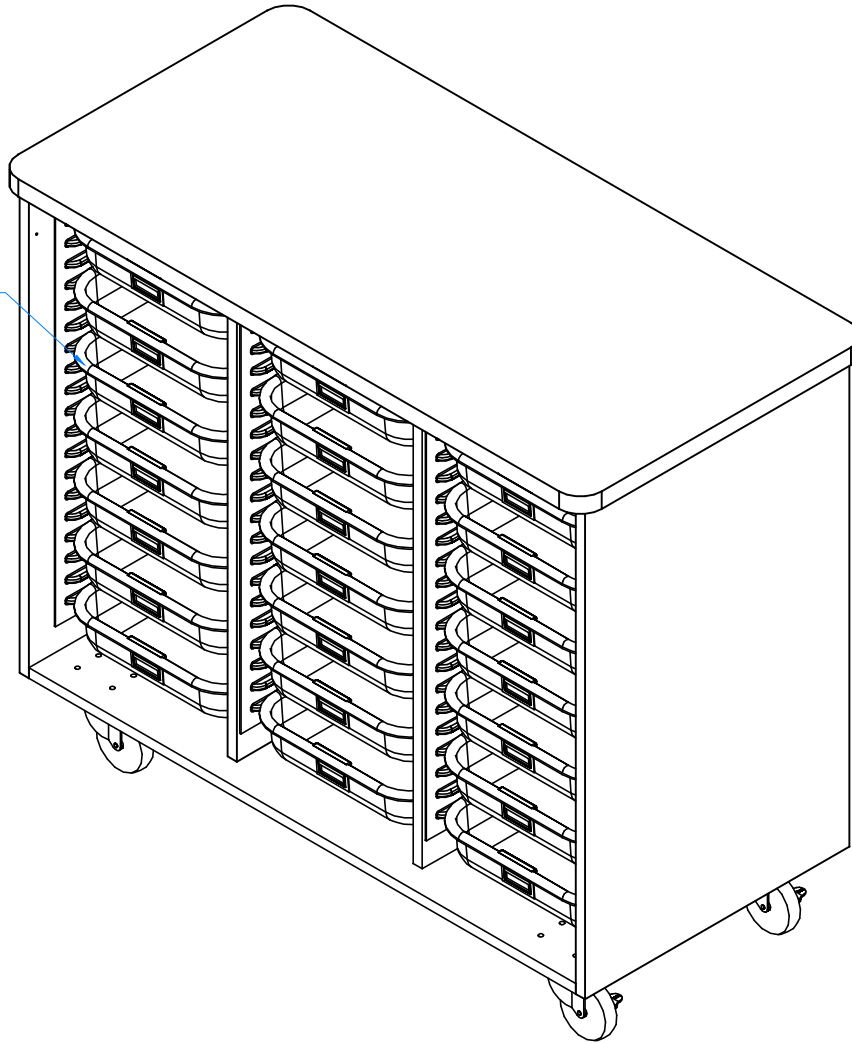

STEP 4:

- IF YOUR UNIT DOES NOT HAVE TOTE TRAYS, SKIP TO STEP 5.
- PLACE TOTE TRAYS IN DESIRED LOCATION.

NOTE:

1. TO REMOVE SLIDING DOORS - SLIDE DOORS TO ONE SIDE. REMOVE EXPOSED SCREWS FROM TOP RAIL. SLIDE DOORS TO OPPOSITE SIDE AND REMOVE REMAINING SCREWS. TILT DOORS AND RAIL OUT. REPEAT STEPS ABOVE IN REVERSE TO PUT DOORS BACK ON.

4901 UNIT SHOWN WITH TOTE TRAYS  
DOORS AND HARDWARE REMOVED TO  
SHOW CLARITY



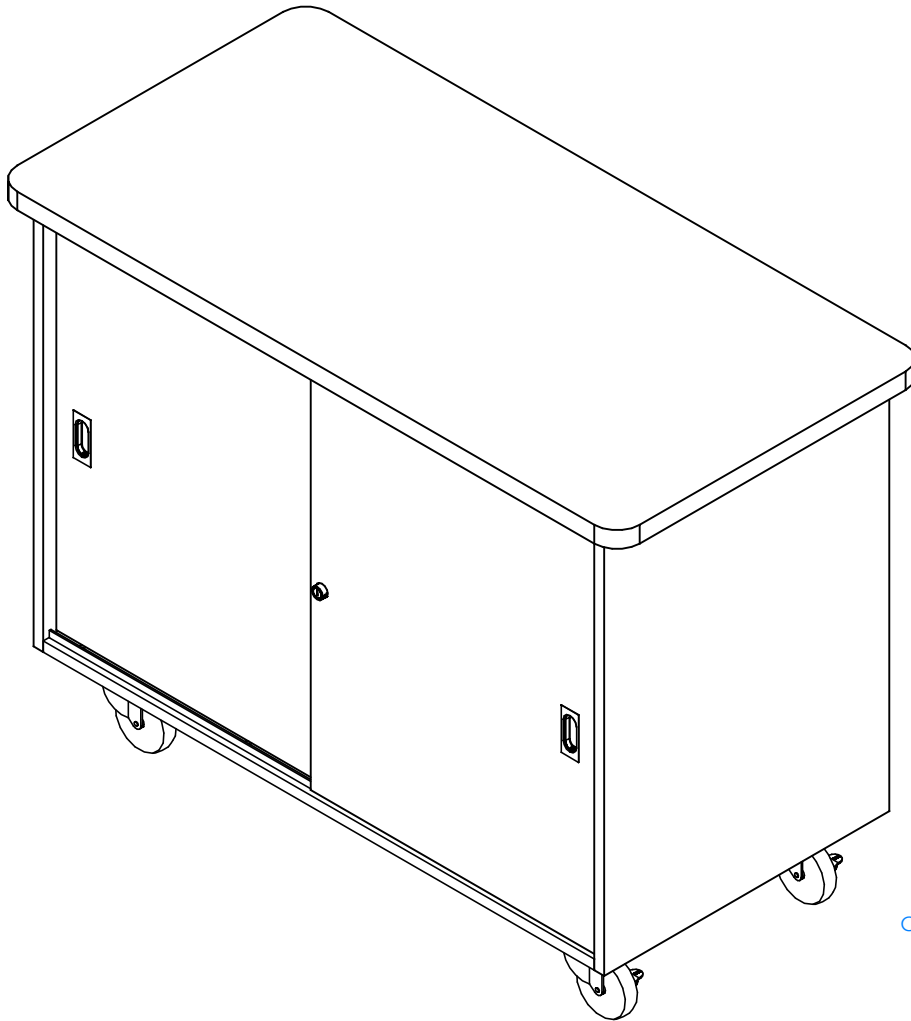

STEP 5:

- SET CABINET IN DESIRED LOCATION.

COMPLETE UNIT SHOWN

NOTE:

1. TO REMOVE SLIDING DOORS - SLIDE DOORS TO ONE SIDE. REMOVE EXPOSED SCREWS FROM TOP RAIL. SLIDE DOORS TO OPPOSITE SIDE AND REMOVE REMAINING SCREWS. TILT DOORS AND RAIL OUT. REPEAT STEPS ABOVE IN REVERSE TO PUT DOORS BACK ON.

